

FRONT ELEVATION
SCALE : (1:100)

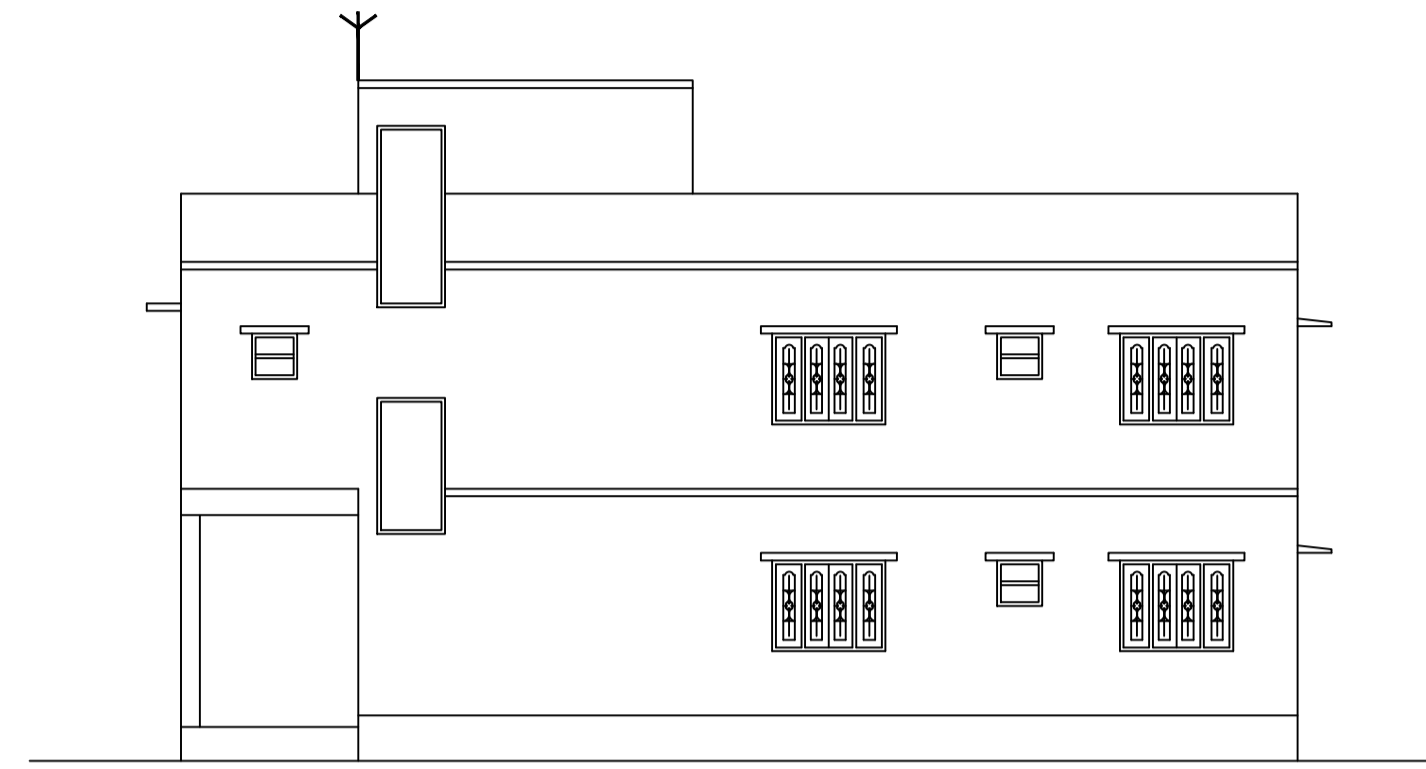

R. SIDE ELEVATION
SCALE : (1:100)

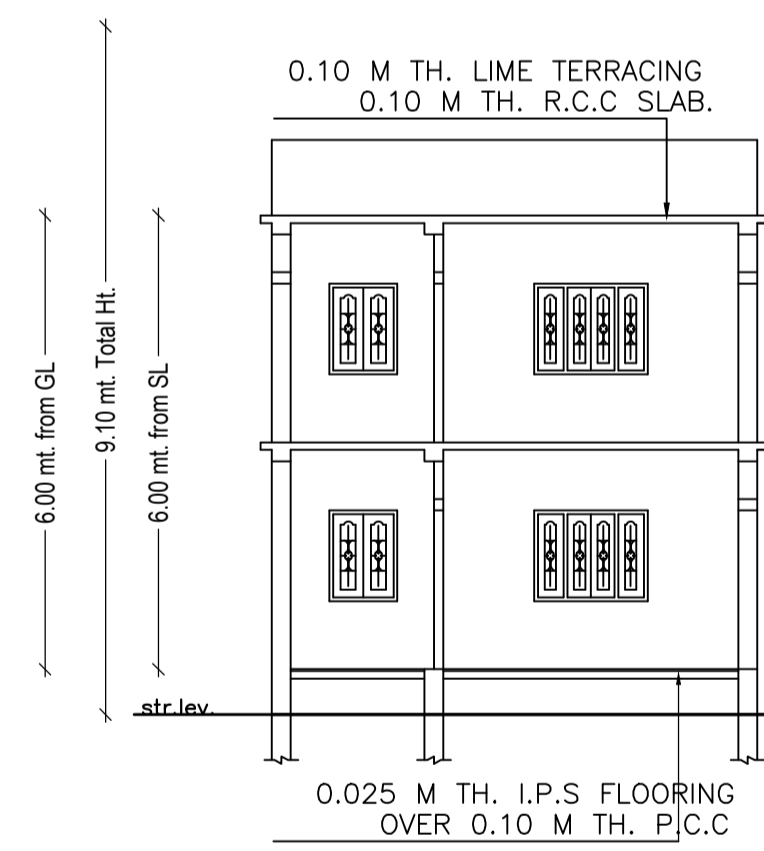

SECTION ON: <1-1>
SCALE : (1:100)

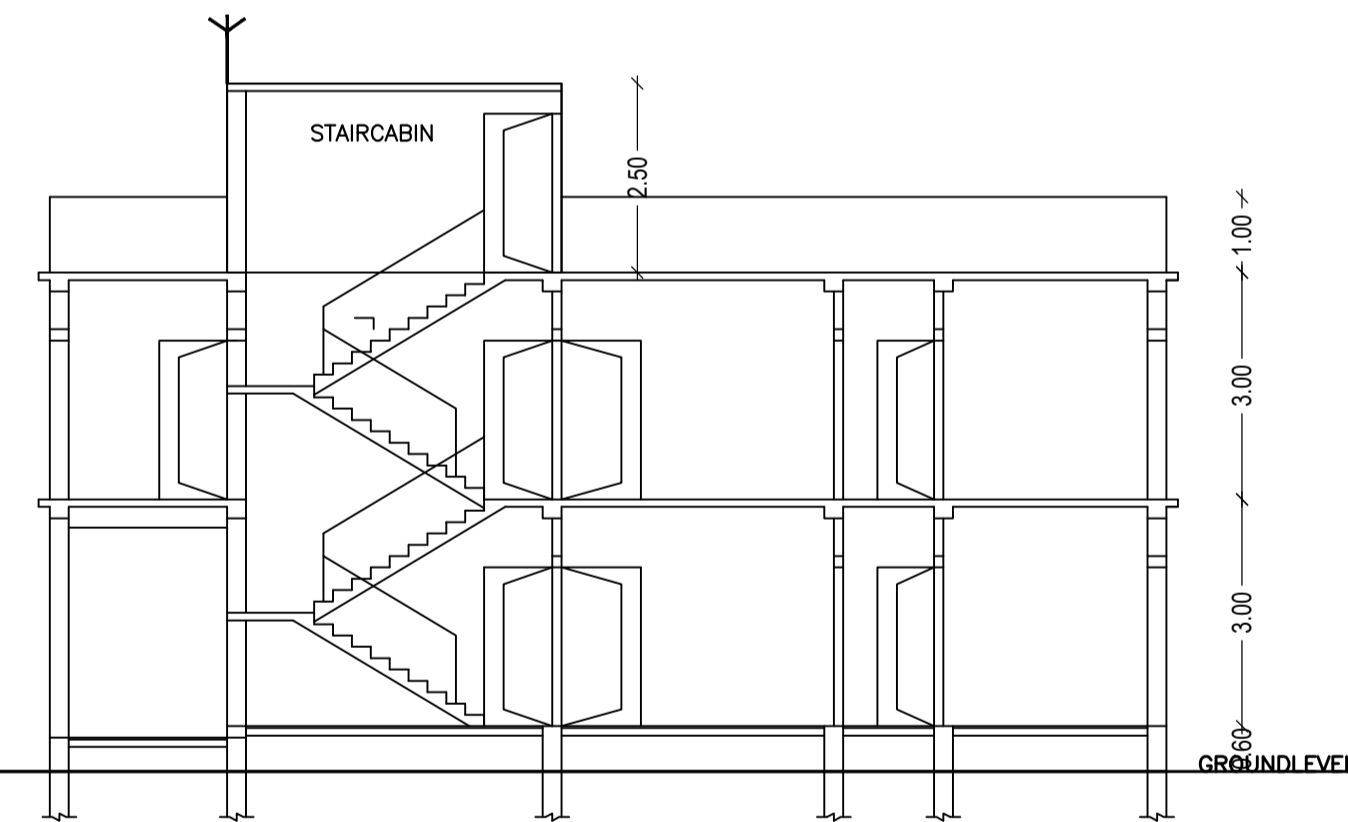

SECTION ON: <2-2>
SCALE : (1:100)

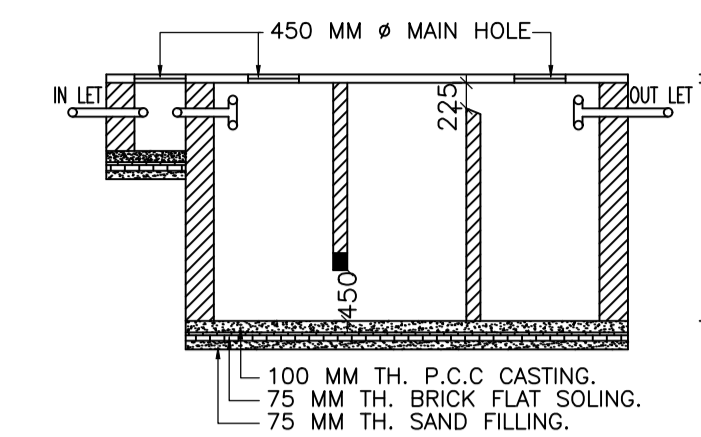

SECTION:-(C-C)

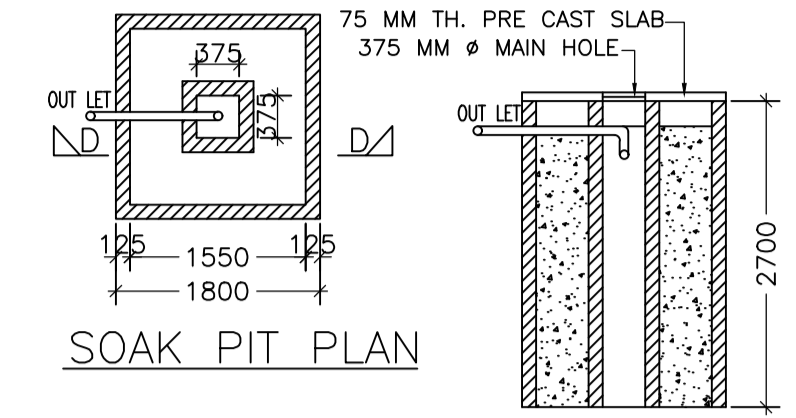

SOAK PIT PLAN

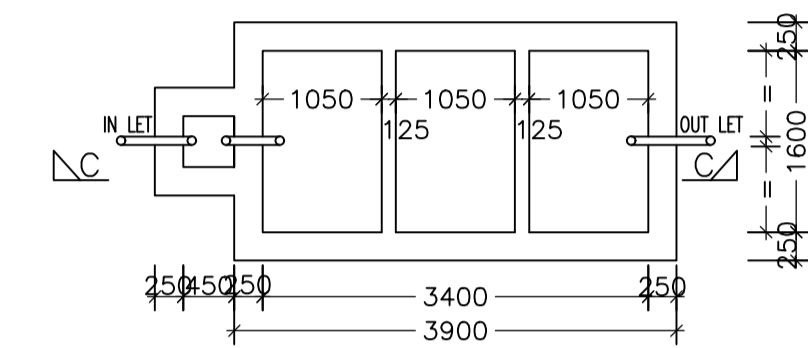

SEPTICK TANK PLAN

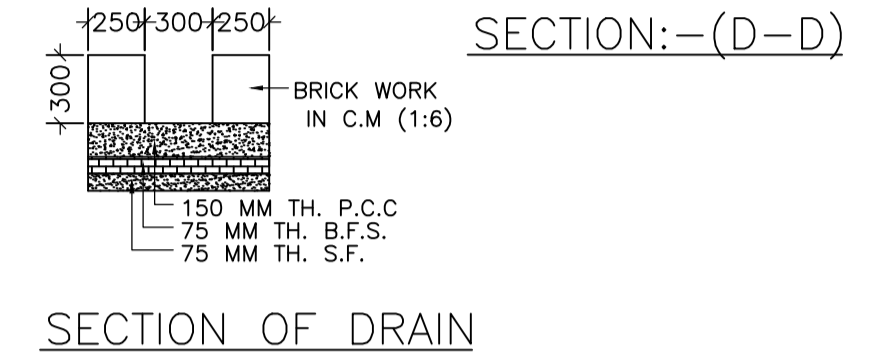

SECTION:-(D-D)

SECTION OF DRAIN

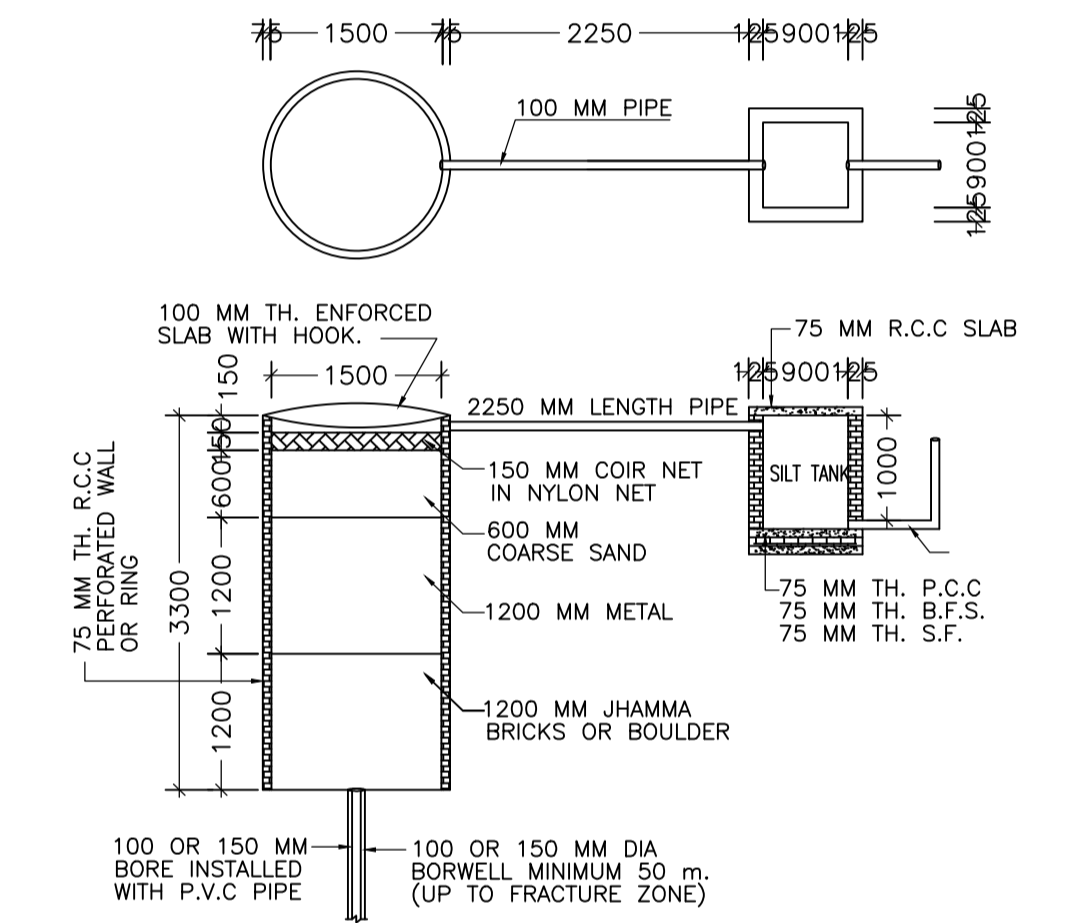

DETAIL OF GROUND WATER RECHARGING PIT WITH SILT TANK

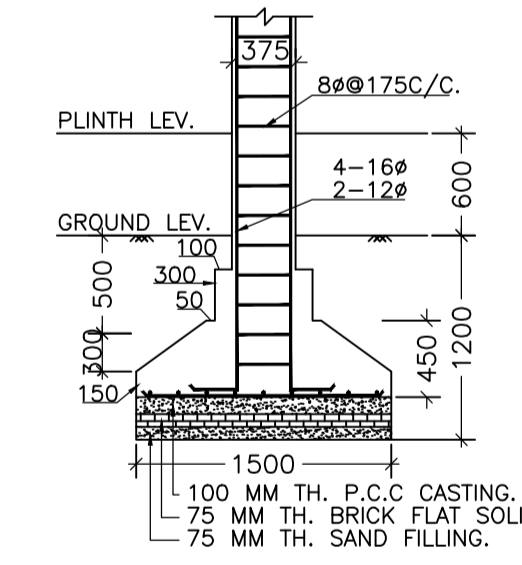

SECTION:-(B-B)

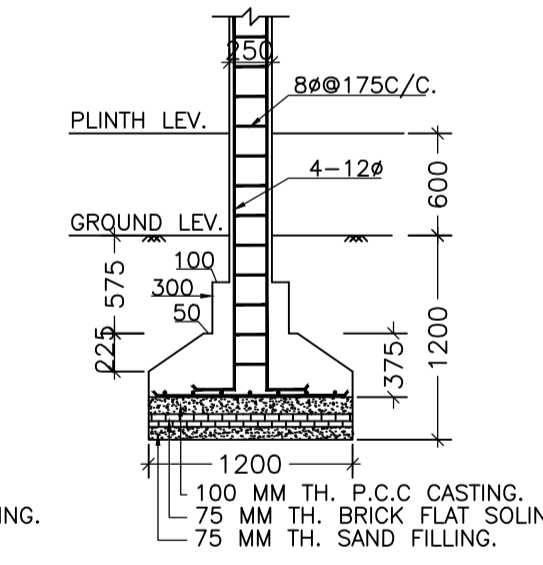

SECTION:-(A-A)

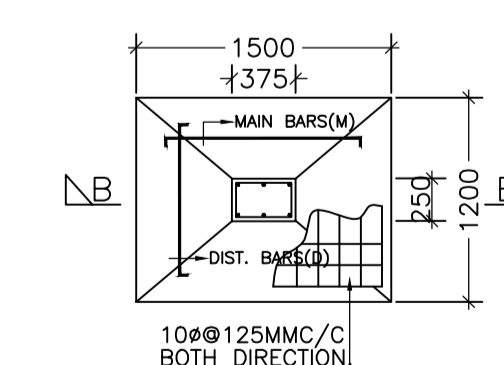

FOUNDATION PLAN OF CLOUMN

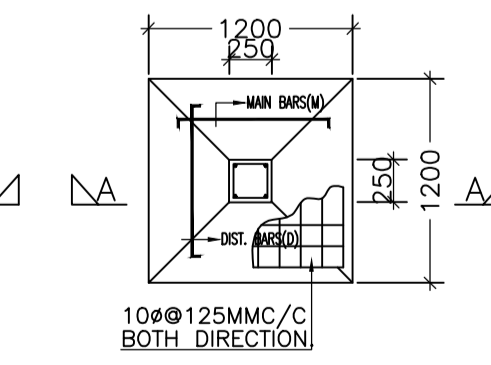

FOUNDATION PLAN OF CLOUMN

LTP NAME AND SIGNATURE	STRUCTURAL ENG'S NAME AND SIGNATURE	BUILDER NAME AND SIGNATURE
balram prasad jaiswal HMC/DFTMN/0009/2016		