

SITE PLAN

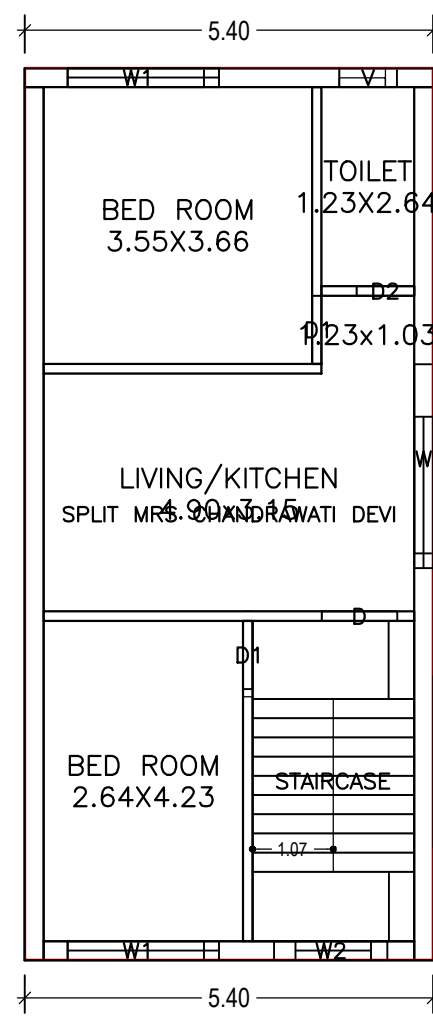

FIRST FLOOR PLAN (Proposed) (SCALE 1:100)

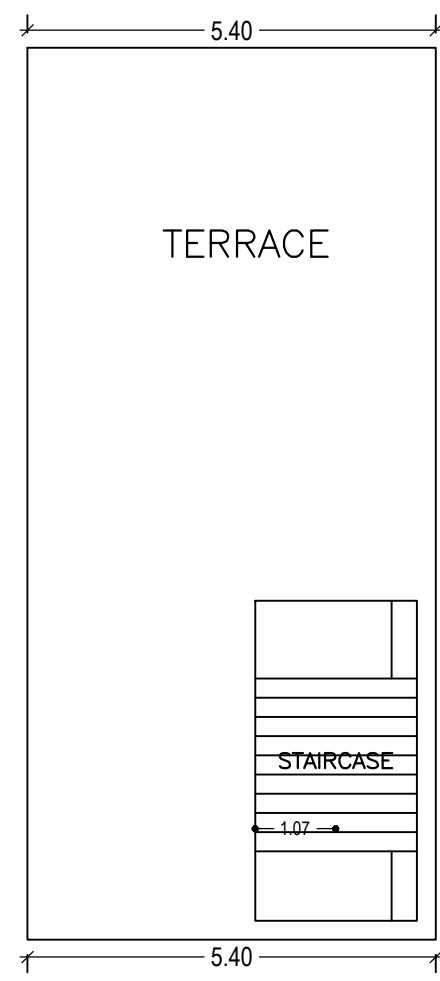

TERRACE FLOOR PLAN (SCALE 1:100)

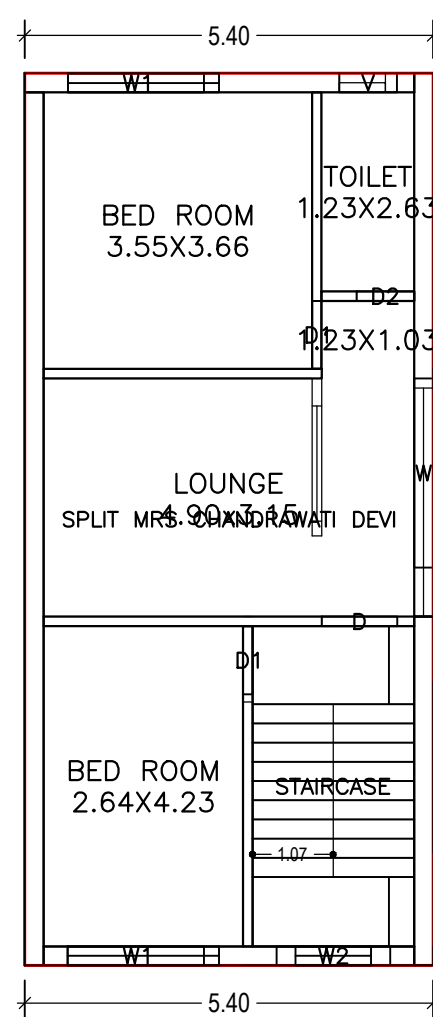

SECOND FLOOR PLAN (Proposed) (SCALE 1:100)

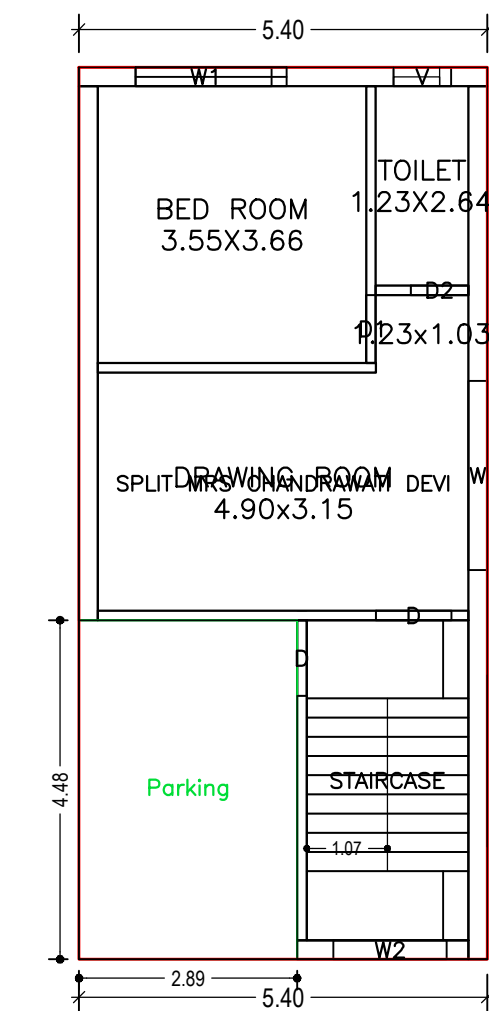

GROUND FLOOR PLAN (Proposed) (SCALE 1:100)

SCHEDULE OF DOOR:

BUILDING NAME	NAME	LENGTH	HEIGHT	NOS
A (MRS CHANDRAWATI DEVI)	D2	0.76	2.13	03
A (MRS CHANDRAWATI DEVI)	D1	0.90	2.13	05
A (MRS CHANDRAWATI DEVI)	D	1.00	2.13	03

SCHEDULE OF WINDOW/VENTILATION:

BUILDING NAME	NAME	LENGTH	HEIGHT	NOS
A (MRS CHANDRAWATI DEVI)	V	0.76	0.76	03
A (MRS CHANDRAWATI DEVI)	W2	1.50	2.50	03
A (MRS CHANDRAWATI DEVI)	W1	1.80	2.50	05
A (MRS CHANDRAWATI DEVI)	W	2.50	2.50	03

UnitBUA Table for Building :A (MRS CHANDRAWATI DEVI)

FLOOR	Name	UnitBUA Type	UnitBUA Area	Carpet Area	No. of Rooms	No. of Tenement
GROUND FLOOR PLAN	SPLIT MRS CHANDRAWATI DEVI	FLAT	124.96	121.73	3	1
FIRST FLOOR PLAN	SPLIT MRS CHANDRAWATI DEVI	FLAT	0.00	0.00	4	0
SECOND FLOOR PLAN	SPLIT MRS CHANDRAWATI DEVI	FLAT	0.00	0.00	4	0
Total:	-	-	124.96	121.73	11	1

Building :A (MRS CHANDRAWATI DEVI)

Floor Name	Total Built Up Area (Sq.mt.)	Proposed FAR Area (Sq.mt.)	Total FAR Area (Sq.mt.)	Total Consumed Additional FAR Area (Sq.mt.)	Tnmt (No.)
Ground Floor	63.72	63.72	63.72	63.72	01
First Floor	63.72	63.72	63.72	63.72	00
Second Floor	63.72	63.72	63.72	63.72	00
Terrace Floor	0.00	0.00	0.00	0.00	00
Total:	191.16	191.16	191.16	191.16	01
Total Number of Same Buildings	1				
Total:	191.16	191.16	191.16	191.16	01

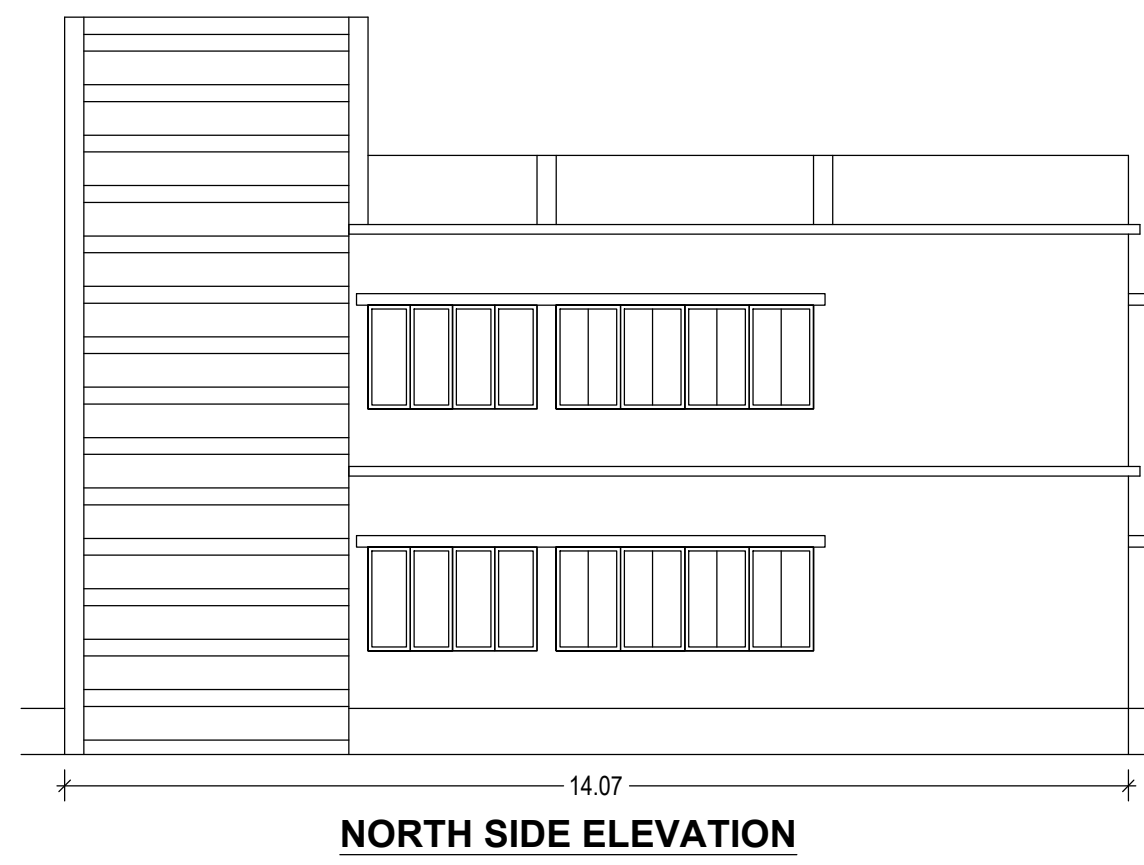

NORTH SIDE ELEVATION

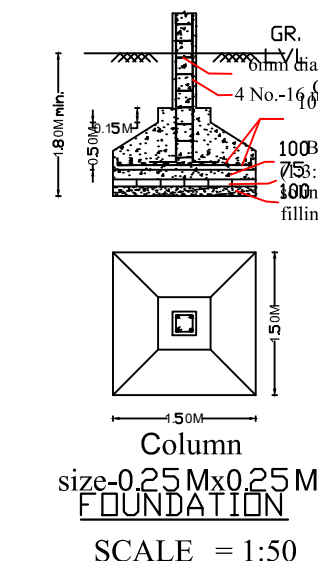

Column size-0.25Mx0.25M. FOUNDATION SCALE = 1:50

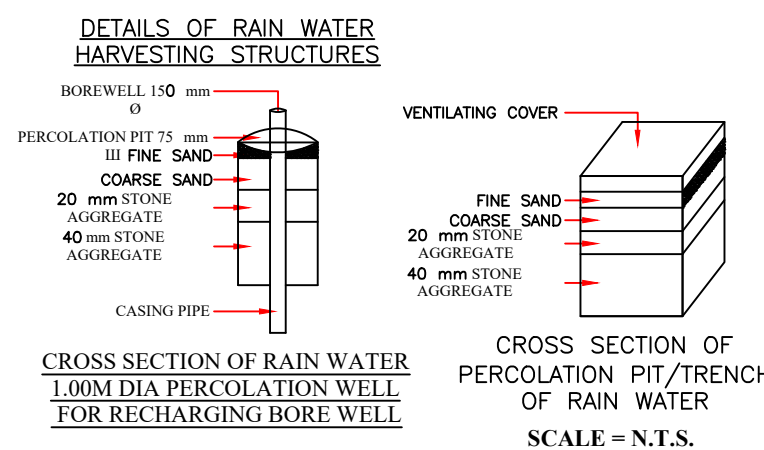

CROSS SECTION OF RAIN WATER PERCOLATION PIT/TRENCH FOR RECHARGING BORE WELL. SCALE = N.T.S.

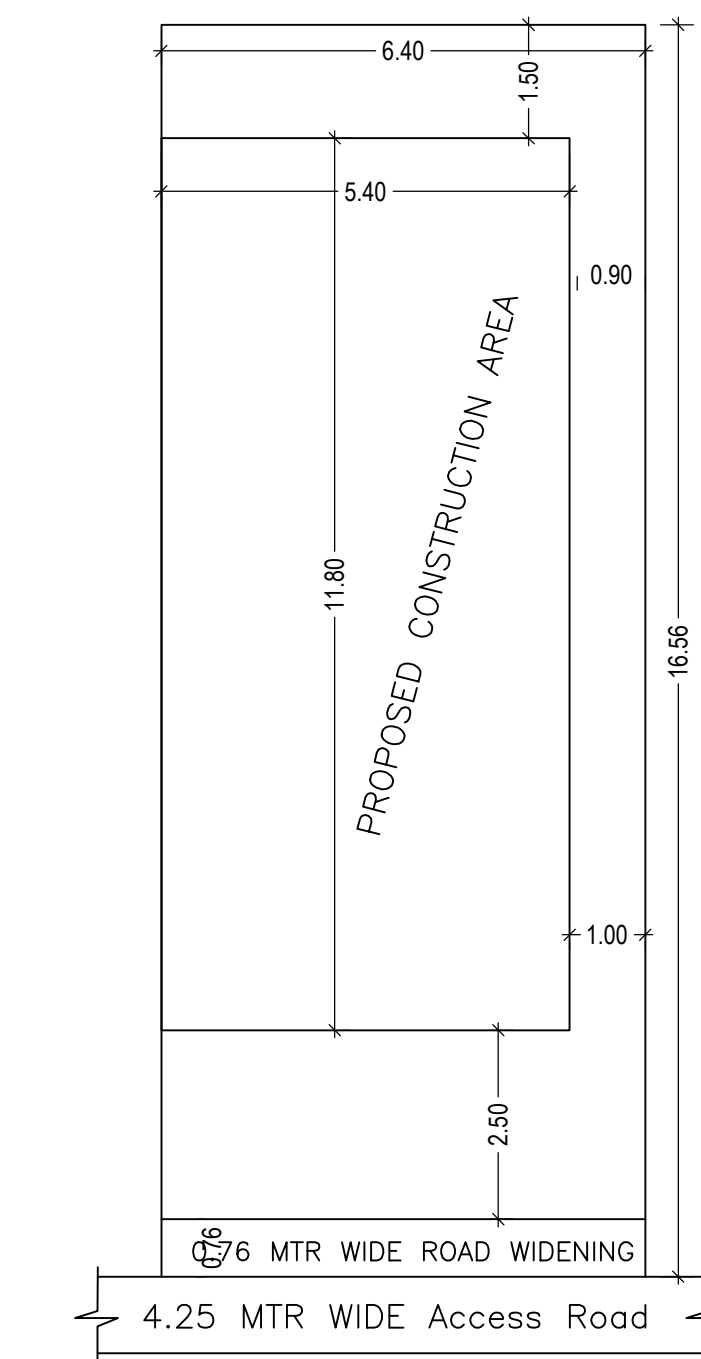

SITE PLAN 1:100

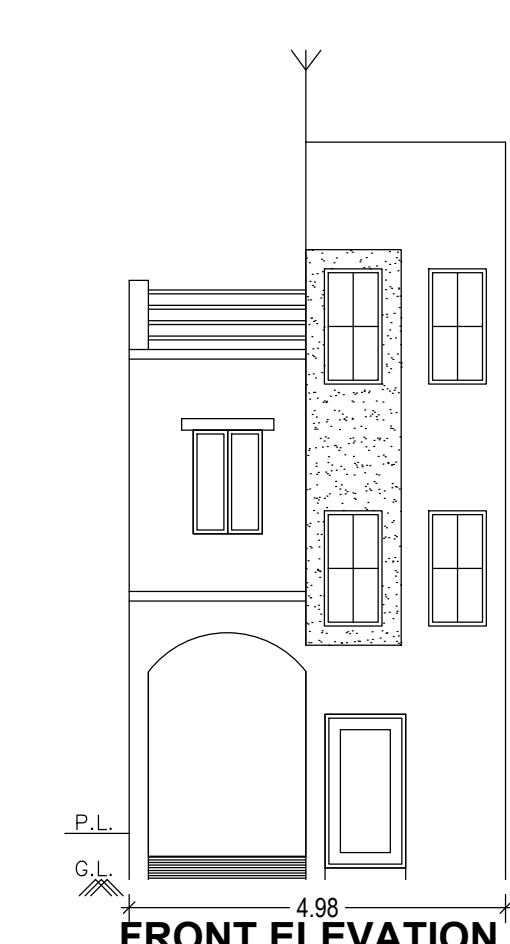

FRONT ELEVATION

AREA STATEMENT SAHIBGANJ NAGAR PARISHAD		VERSION NO.: 1.0.25	DATE
PROJECT DETAIL:		VERSION DATE: 12/04/2018	10-05-2018
Region: JHARKHAND URBAN	Plot Use: Residential		
Local Bodies: SAHIBGANJ	Plot SubUse: Residential Bldg/Apartment		
District: SAHIBGANJ	PlotNearbyReligiousStructure: NA		
Authority: SAHIBGANJ NAGAR PARISHAD			
Inward No: SNP/BP/0002/W1/2018	Plot/SubPlot No: 1827		
Application Type: General Proposal	North: -		
Project Type: Building Permission	South: -		
Nature of Development: New	East: -		
Location of Development Area: Old Area	West: -		
AREA DETAILS:			
AREA OF PLOT (Minimum)	(A)	SQ.MT.	105.98
Deduction for NetPlot Area			
Surrender Free of Cost			4.86
Total			4.86
NET AREA OF PLOT(Gross Plot Area - Deduction from Gross Plot area)	(A-Deductions)		101.12
Deduction for Balance Plot Area(from Gross Plot Area)			
Surrender Free of Cost			4.86
Common Plot			14.97
Total			19.83
BALANCE AREA OF PLOT(Net Plot Area - Recreational/Amenity space)	(A-Deductions)		86.15
PLOT AREA FOR COVERAGE(Net Plot Area)	(A-Deductions)		101.12
Plot Area for FAR (Net Plot Area + RoadWidening Area)	(A-Deductions)		105.98
COVERAGE CHECK			
Permissible Coverage area (70.00 %)			70.78
Proposed Coverage Area (63.02 %)			63.72
Total Prop. Coverage Area (63.02 %)			63.72
Balance coverage area (6.98 %)			7.06
FAR CHECK			
Perm. FAR Area (1.50)			158.97
Maximum Permissible FAR Area (2.00)			211.96
Total Perm. FAR area			211.96
Residential FAR			191.16
Proposed FAR Area			191.16
Total Proposed FAR Area			191.16
Consumed FAR (Factor)			1.80
Balance FAR Area			20.80
Total Paid Proposed FAR Area			32.19
BUILT UP AREA CHECK			
Total Proposed BuiltUp Area			191.16
ARCHITECT (Regd) RAJ GOTHWAL			
ENGINEER (Regd)			
SUPERVISOR (Regd)			
OWNER (Regd) MRS CHANDRAWATI DEVI			
DEVELOPMENT AUTHORITY LOCAL BODY			

COLOR INDEX	
PLOT BOUNDARY	Black
ABUTTING ROAD	Green
PROPOSED CONSTRUCTION	Red
COMMON PLOT	Yellow
ROAD WIDENING AREA	Blue
EXISTING (To be retained)	Orange
EXISTING (To be demolished)	Light Blue

Buildingwise Floor FAR Details

Floor Name	Building Name		Total			
	Proposed Built Up Area (Sq.mt.)	Proposed FAR Area (Sq.mt.)	Total Proposed Built Up Area (Sq.mt.)	Total FAR Area (Sq.mt.)	Total Maximum Permissible FAR Area (Sq.mt.)	Total Paid Built Up Area (Sq.mt.)
Ground Floor	63.72	63.72	63.72	63.72	32.19	32.19
First Floor	63.72	63.72	63.72	63.72	0.00	0.00
Second Floor	63.72	63.72	63.72	63.72	0.00	0.00
Terrace Floor	0.00	0.00	0.00	0.00	0.00	0.00
Total:	191.16	191.16	191.16	191.16	32.19	32.19

Building USE/SUBUSE Details

Building Name	Building Use	Building SubUse	Building Structure
A (MRS CHANDRAWATI DEVI)	Residential	Residential Bldg/Apartment	Non-Highrise

FAR & Tenement Details (Table 4c-1)

Building	No. of Same Bldg	Total Built Up Area (Sq.mt.)	Proposed FAR Area (Sq.mt.)	Total FAR Area (Sq.mt.)	Total Consumed Additional FAR Area (Sq.mt.)	Tnmt (No.)
A (MRS CHANDRAWATI DEVI)	1	191.16	191.16	191.16	191.16	01
Grand Total:	1	191.16	191.16	191.16	191.16	01

LTP NAME AND SIGNATURE	STRUCTURAL ENG'S NAME AND SIGNATURE	BUILDER NAME AND SIGNATURE
RAJ GOTHWAL SNP/ARC/0001/2016		