

AREA STATEMENT ADITYAPUR MUNICIPAL CORPORATION	VERSION NO.: 1.0.22 VERSION DATE: 28/09/2017
PROJECT DETAIL:	
Region: JHARKHAND URBAN LOCAL BODIES	Plot Use: Residential
District: EAST SINGHBHUM	Plot SubUse: Lodging
Authority: ADITYAPUR MUNICIPAL CORPORATION	PlotNearby/ReligiousStructure: NA
Inward_No: AMC/BP/0019/W17/2017	Plot/SubPlot No: 708(O)1604(N)
Application Type: General Proposal	North: -
Project Type: Building Permission	South: -
Nature of Development: New	East: -
Location of Development Area: Old Area	West: -
AREA DETAILS:	
AREA OF PLOT (Minimum)	(A) 111.48 SQ.MT.
Deduction for NetPlot Area	
Road Widening Area	6.40
Total	6.40
NET AREA OF PLOT(Gross Plot Area - Deduction from Gross Plot area)	(A-Deductions) 105.08
Deduction for Balance Plot Area(from Gross Plot Area)	
Road Widening Area	6.40
Common Plot	11.28
Total	17.68
BALANCE AREA OF PLOT(Net Plot Area - Recreational/Amenity space)	(A-Deductions) 93.80
PLOT AREA FOR COVERAGE(Net Plot Area)	(A-Deductions) 105.08
Plot Area for FAR (Net Plot Area - RoadWidening Area)	(A-Deductions) 105.08
COVERAGE CHECK	
Permissible Coverage area ( 70.00 % )	73.56
Proposed Coverage Area ( 62.71 % )	65.90
Total Prop. Coverage Area ( 62.71 % )	65.90
Balance coverage area ( 7.29 % )	7.66
FAR CHECK	
Perm. FAR Area ( 2.50 )	262.70
Total Perm. FAR area	262.70
Residential FAR	170.97
Proposed FAR Area	170.97
Total Proposed FAR Area	170.97
Consumed FAR (Factor)	1.63
Balance FAR Area	91.73
BUILT UP AREA CHECK	
Total Proposed BuiltUp Area	210.21
ARCHITECT (Regd)	MUKESH KUMAR
ENGINEER (Regd)	
SUPERVISOR (Regd)	
OWNER (Regd)	Mr. ESHWAR CHANDRA JHA
DEVELOPMENT AUTHORITY LOCAL BODY	

COLOR INDEX	
PLOT BOUNDARY	
ABUTTING ROAD	
PROPOSED CONSTRUCTION	
COMMON PLOT	
ROAD WIDENING AREA	
EXISTING (To be retained)	
EXISTING (To be demolished)	

Buildingwise Floor FAR Details

Floor Name	Building Name		Total	
	Proposed Built Up Area (Sq.mt.)	Proposed FAR Area (Sq.mt.)	Total Proposed Built Up Area (Sq.mt.)	Total FAR Area (Sq.mt.)
Ground Floor	78.39	39.15	78.39	39.15
First Floor	65.91	65.91	65.91	65.91
Second Floor	65.91	65.91	65.91	65.91
Terrace Floor	0.00	0.00	0.00	0.00
Total :	210.21	170.97	210.21	170.97

Building USE/SUBUSE Details

Building Name	Building Use	Building SubUse	Building Structure
A (BUILDING)	Residential	Bungalow/ Dwelling / Non Apartment	Non-Highrise

FAR & Tenement Details (Table 4c-1)

Building	No. of Same Bldg	Total Built Up Area (Sq.mt.)	Deductions (Area in Sq.mt.)		Proposed FAR Area (Sq.mt.)	Total FAR Area (Sq.mt.)	Total Consumed Additional FAR Area (Sq.mt.)	Tnmt (No.)
			Parking	Resi.				
A (BUILDING)	1	210.21	39.24	170.97	170.97	170.97	170.97	01
Grand Total :	1	210.21	39.24	170.97	170.97	170.97	170.97	01

LTP NAME AND SIGNATURE	STRUCTURAL ENG'S NAME AND SIGNATURE	BUILDER NAME AND SIGNATURE
MUKESH KUMAR AMC/ENG/0004/2017		

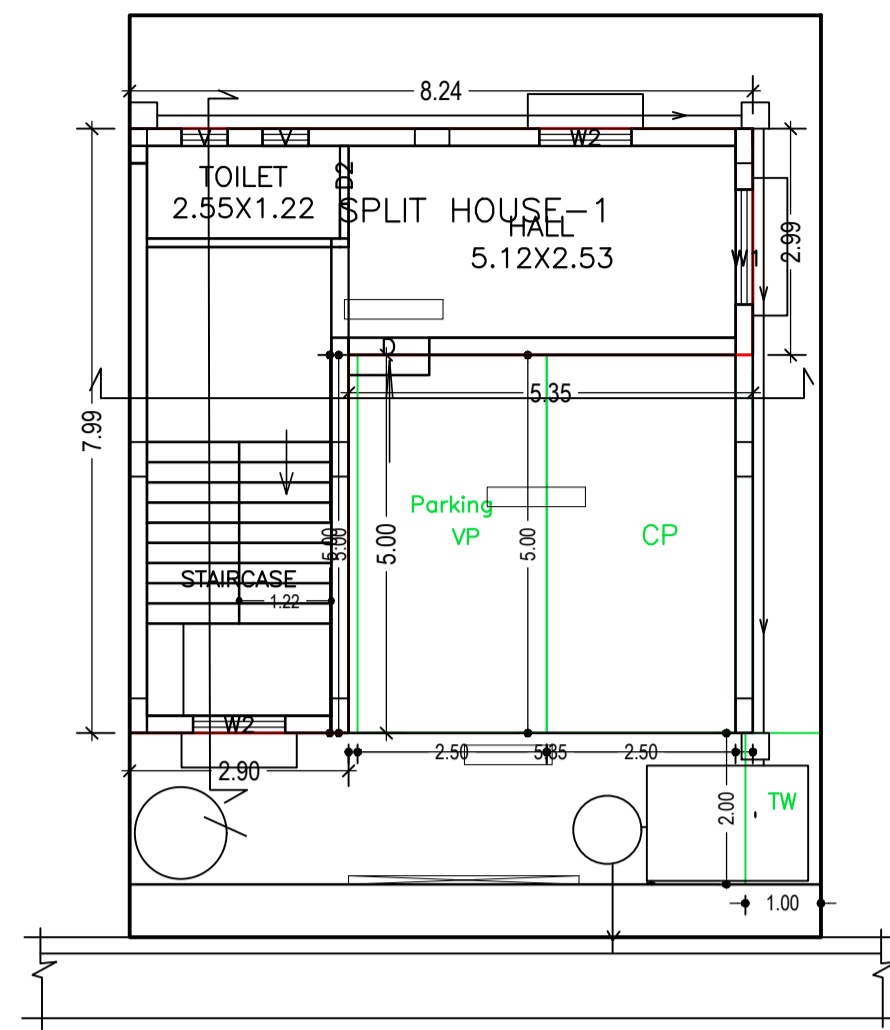
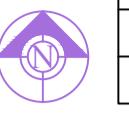

GROUND FLOOR PLAN  
(Proposed)  
(SCALE 1:100)

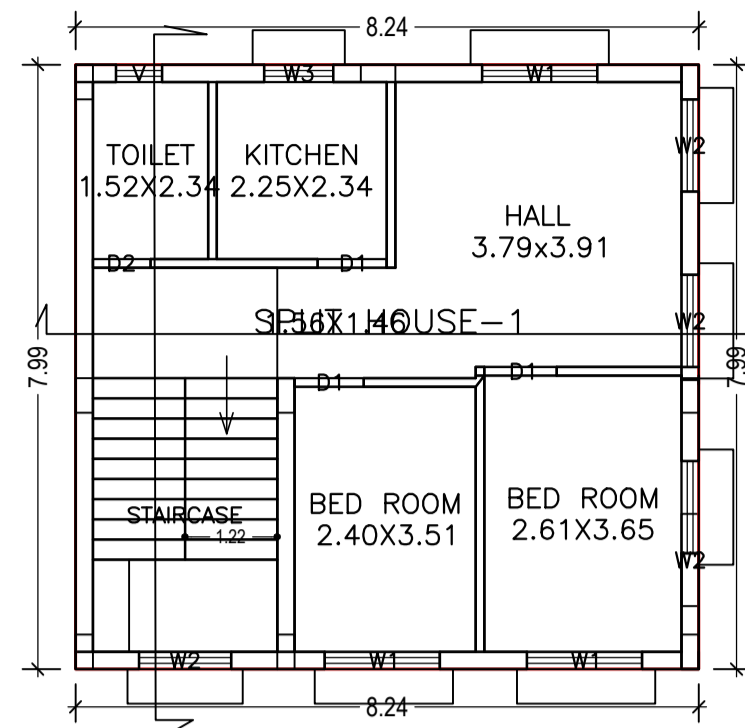

TYPICAL - 1& 2 FLOOR PLAN  
(Proposed)  
(SCALE 1:100)

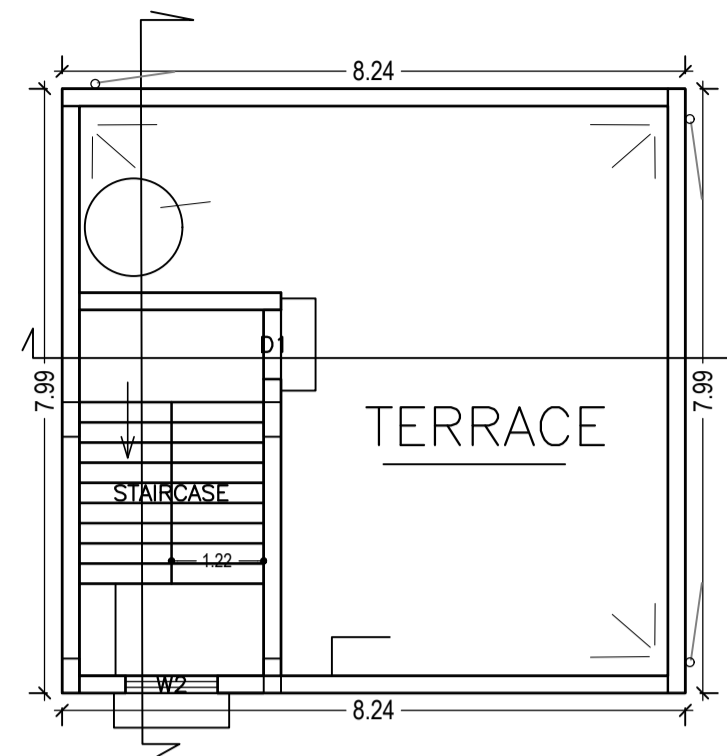

TERRACE FLOOR PLAN  
(SCALE 1:100)

Building :A (BUILDING)

Floor Name	Total Built Up Area (Sq.mt.)	Deductions (Area in Sq.mt.)		Proposed FAR Area (Sq.mt.)	Total FAR Area (Sq.mt.)	Total Consumed Additional FAR Area (Sq.mt.)	Trmt (No.)
		Parking	Resi.				
Ground Floor	78.39	39.24	39.15	39.15	39.15	39.15	01
First Floor	65.91	0.00	65.91	65.91	65.91	65.91	00
Second Floor	65.91	0.00	65.91	65.91	65.91	65.91	00
Terrace Floor	0.00	0.00	0.00	0.00	0.00	0.00	00
Total:	210.21	39.24	170.97	170.97	170.97	170.97	01
Total Number of Same Buildings :	1						
Total :	210.21	39.24	170.97	170.97	170.97	170.97	01

SCHEDULE OF DOOR:

BUILDING NAME	NAME	LENGTH	HEIGHT	NOS
A (BUILDING)	D2	0.76	2.10	03
A (BUILDING)	D1	0.91	2.10	04
A (BUILDING)	D1	0.96	2.10	02
A (BUILDING)	D	1.07	2.10	01

SCHEDULE OF WINDOW/VENTILATION:

BUILDING NAME	NAME	LENGTH	HEIGHT	NOS
A (BUILDING)	V	0.61	1.20	04
A (BUILDING)	W3	0.91	1.20	02
A (BUILDING)	D1	0.91	1.20	01
A (BUILDING)	W2	1.22	1.20	11
A (BUILDING)	W1	1.52	1.20	07

LTP NAME AND SIGNATURE	STRUCTURAL ENG'S NAME AND SIGNATURE	BUILDER NAME AND SIGNATURE
MUKESH KUMAR AMC/ENG/0004/2017		

UnitBUA Table for Building :A (BUILDING)

FLOOR	Name	UnitBUA Type	UnitBUA Area	Carpet Area	No. of Rooms	No. of Tenement
GROUND FLOOR PLAN	SPLIT HOUSE-1	FLAT	170.97	142.96	2	1
TYPICAL -1& 2 FLOOR PLAN	SPLIT HOUSE-1	FLAT	0.00	0.00	5	0
<b>Total:</b>			170.97	142.96	12	1

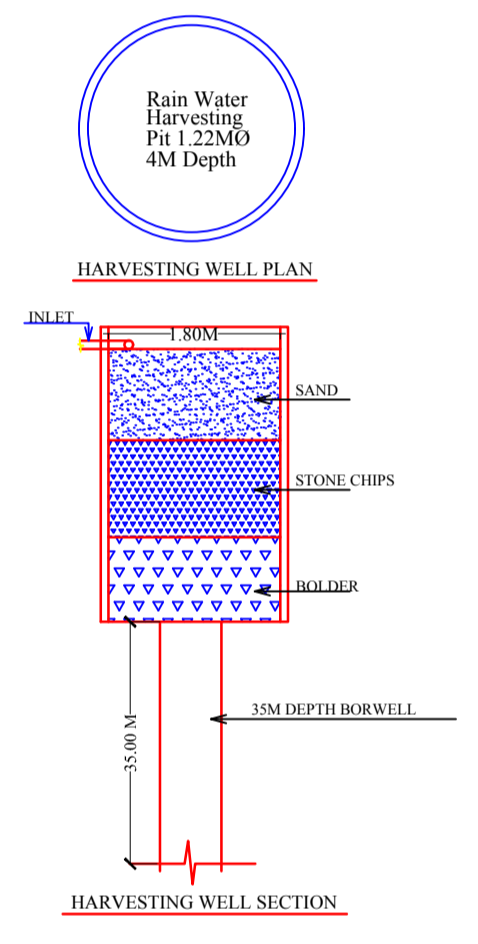
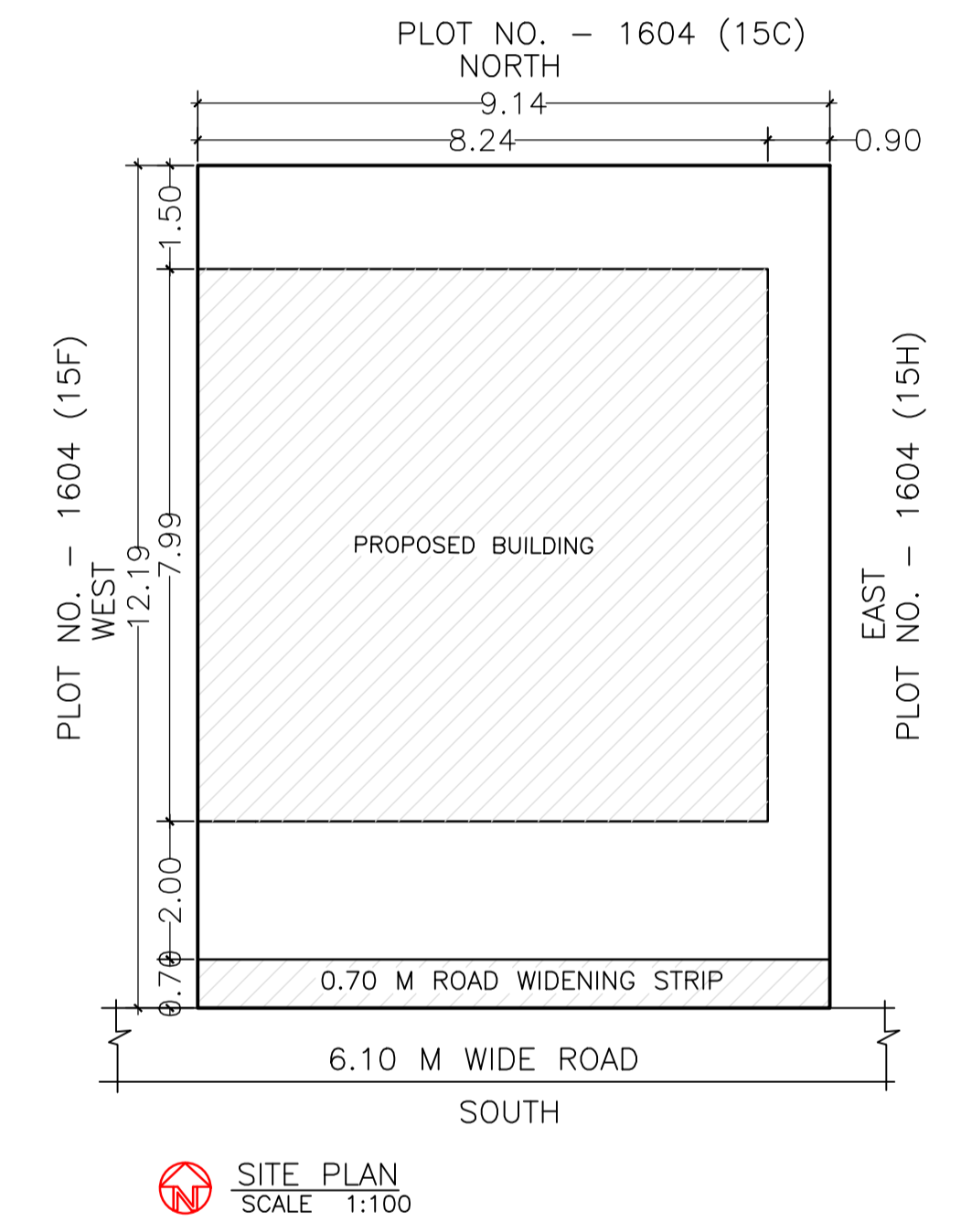
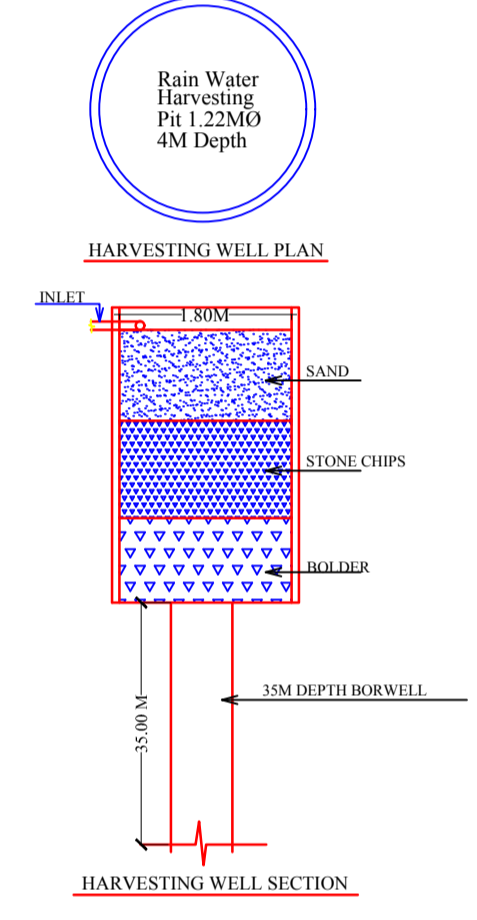
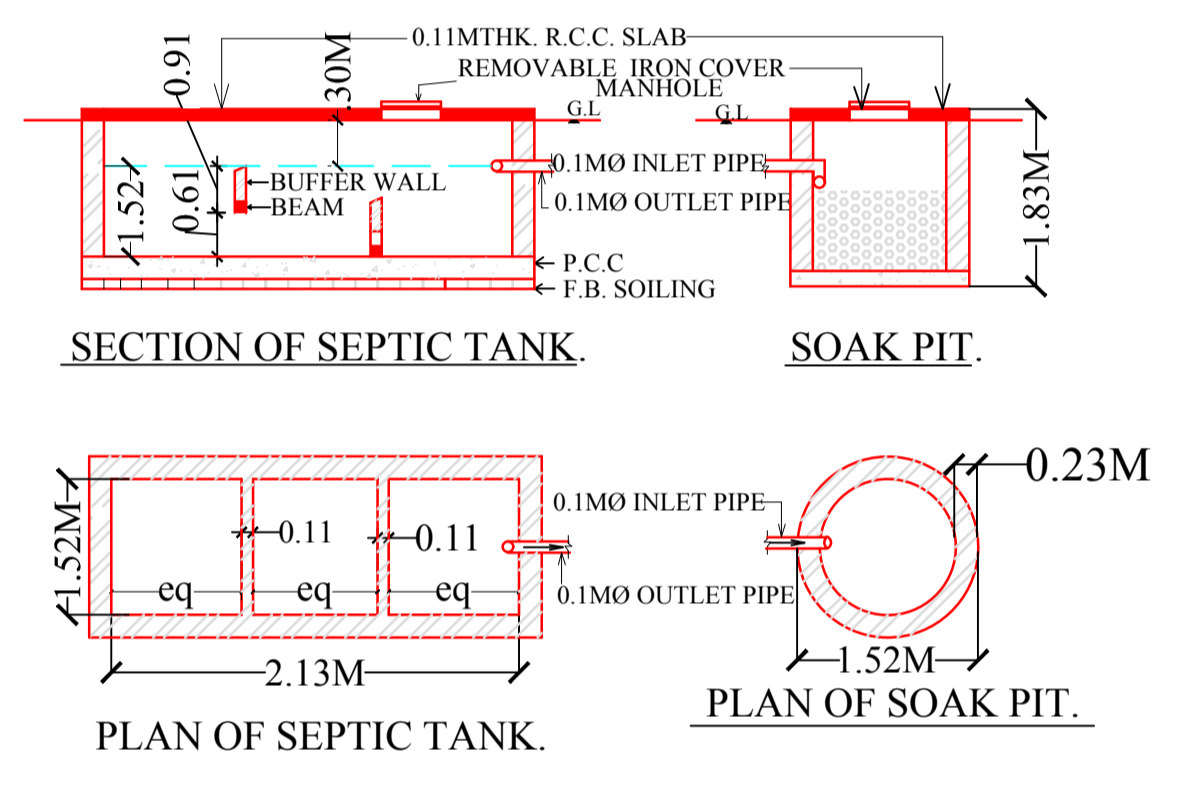
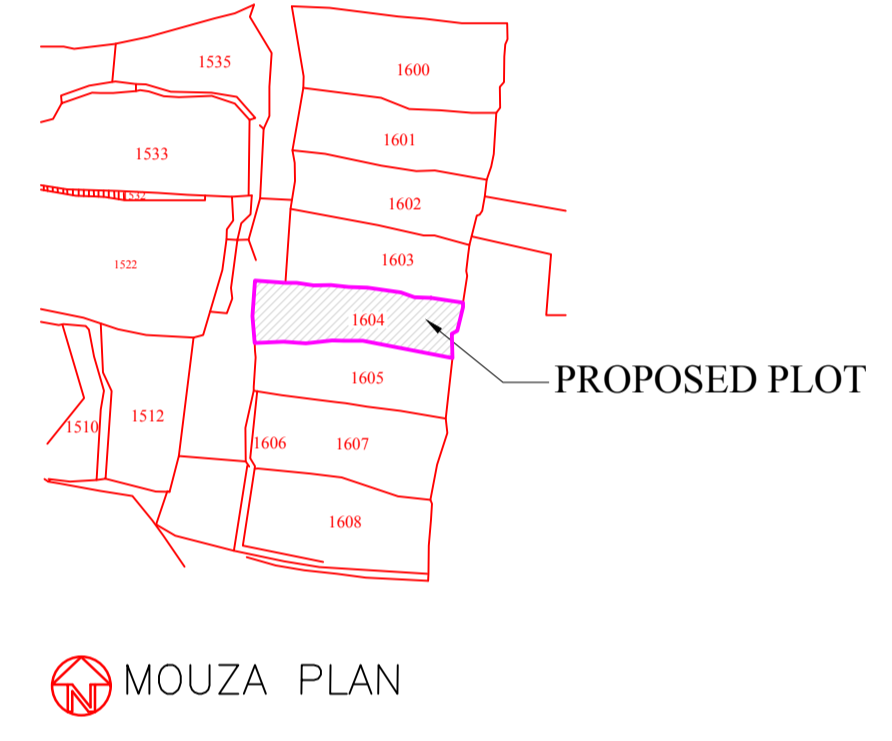
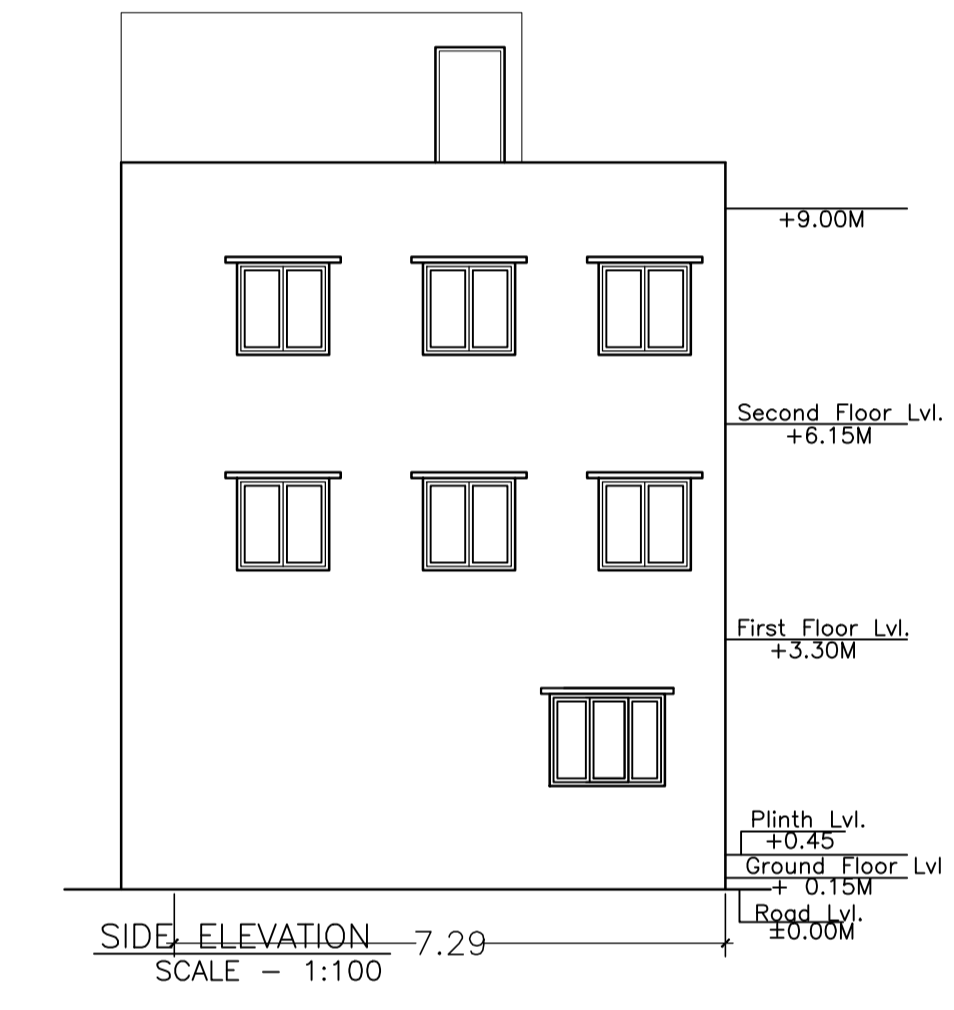
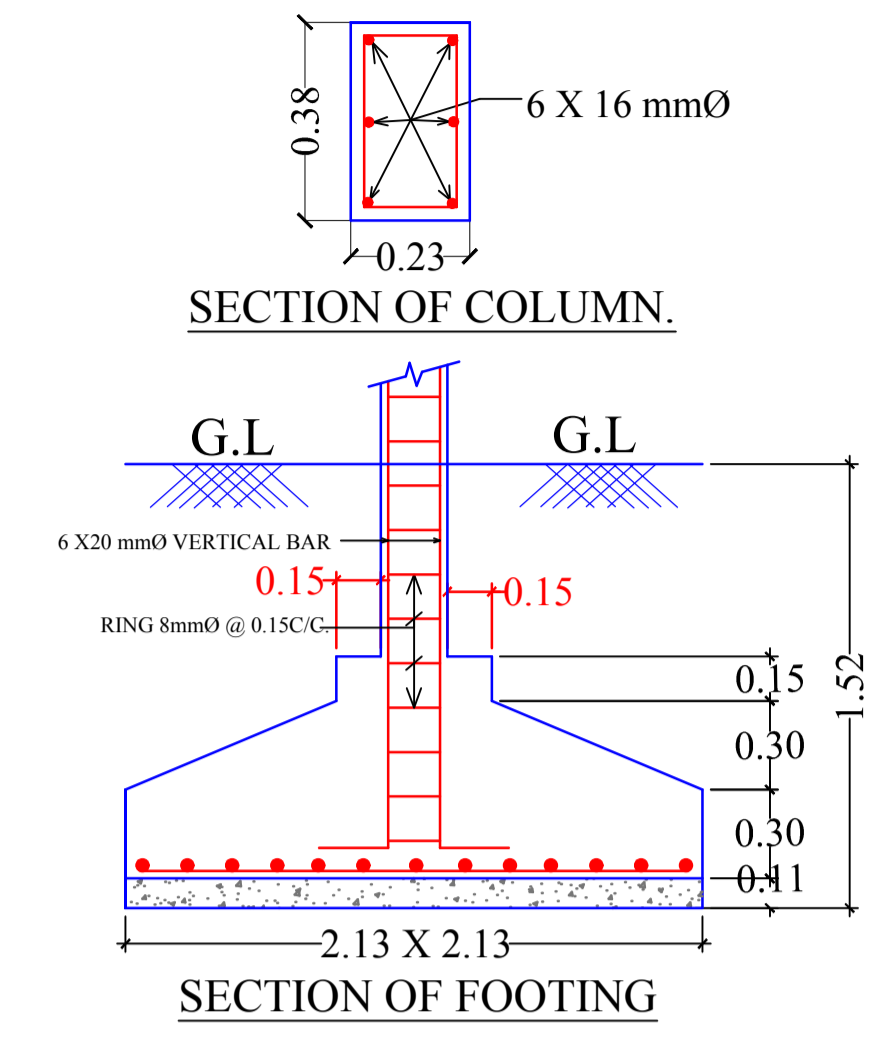
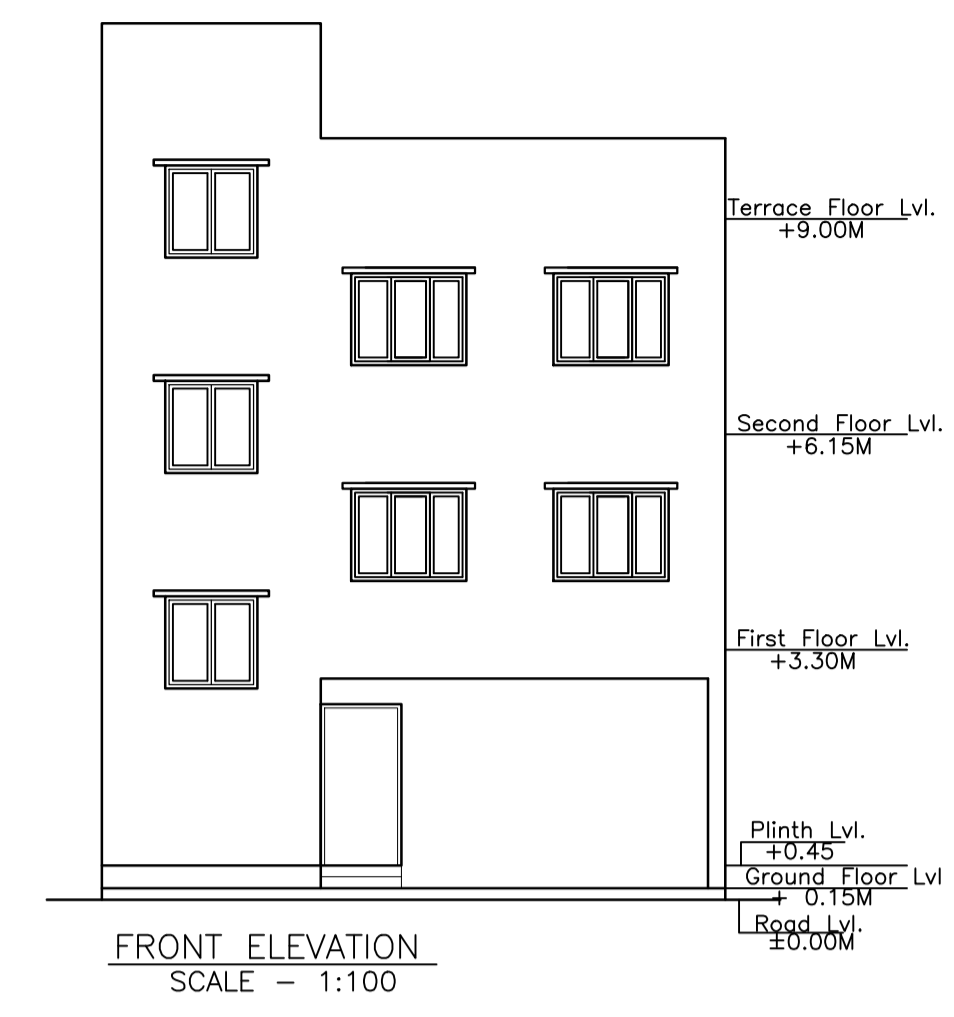
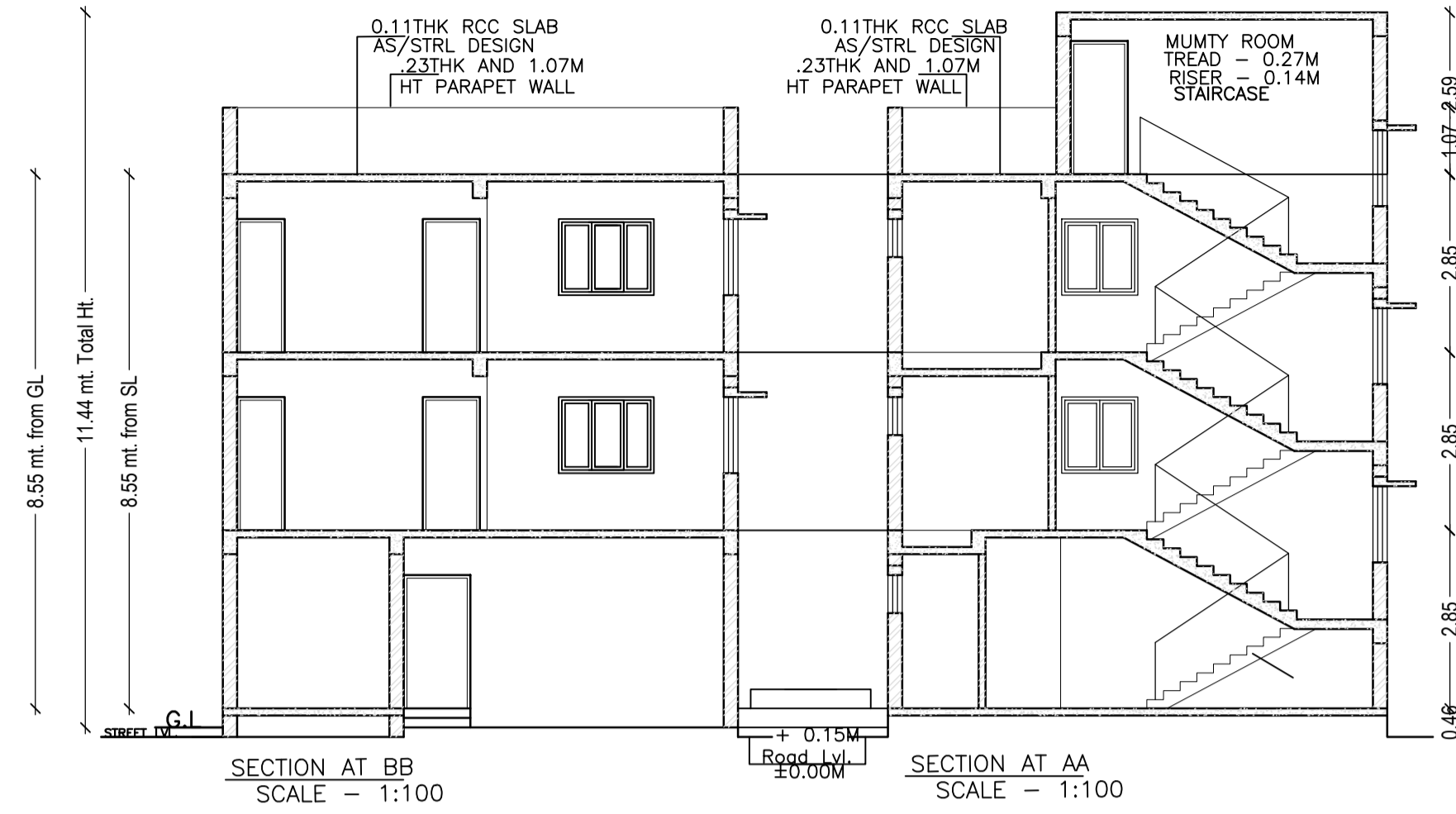

LTP NAME AND SIGNATURE	STRUCTURAL ENG'S NAME AND SIGNATURE	BUILDER NAME AND SIGNATURE
MUKESH KUMAR AMC/ENG/0004/2017		