

site plan

AREA STATEMENT	ADITYAPUR MUNICIPAL CORPORATION	VERSION NO.: 1.0.30
LOCAL BODIES	District: EAST SINGHBHUM	VERSION DATE: 30/06/2018
PROJECT DETAIL:	Region: JHARKHAND URBAN	Plot Use: Residential
	Plot SubUse: Bungalow/ Dwelling / Non Apartment	
	Plot Nearby Religious Structure: NA	
	Inward No: AMC/BP/0030/W22/2018	Plot/SubPlot No: 2481(NEW), 456(OLD)
	Application Type: General Proposal	North: -
	Project Type: Building Permission	South: -
	Nature of Development: New	East: -
	Location of Development Area: Old Area	West: -
AREA DETAILS:		SQ.MT.
AREA OF PLOT (Minimum)	(A)	87.36
NET AREA OF PLOT (Gross Plot Area - Deduction from Gross Plot area)	(A-Deductions)	87.36
Deduction for Balance Plot Area (from Gross Plot Area)		
Common Plot		7.44
Total		7.44
BALANCE AREA OF PLOT (Net Plot Area - Recreational/Amenity space)	(A-Deductions)	79.92
PLOT AREA FOR COVERAGE (Net Plot Area)	(A-Deductions)	87.36
Plot Area for FAR (Net Plot Area + Road Widening Area)	(A-Deductions)	87.36
COVERAGE CHECK		
Permissible Coverage area ( 70.00 % )		61.15
Proposed Coverage Area ( 60.83 % )		53.14
Total Prop. Coverage Area ( 60.83 % )		53.14
Balance coverage area ( 9.17 % )		8.01
FAR CHECK		
Perm. FAR Area ( 2.50 )		218.40
Total Perm. FAR area		218.40
Residential FAR		113.93
Proposed FAR Area		113.93
Total Proposed FAR Area		113.93
Consumed FAR (Factor)		1.30
Balance FAR Area		104.47
BUILT UP AREA CHECK		
Total Proposed BuiltUp Area		113.93
ARCHITECT (Regd)	MOHAMMAD BELAL NASIR	
ENGINEER (Regd)		
SUPERVISOR (Regd)		
OWNER (Regd)	(1) MRS. SONI DEVI (2) MR. DHIRAJ KUMAR VERMA (3) MR. SURAJ KUMAR VERMA	
DEVELOPMENT AUTHORITY	LOCAL BODY	

COLOR INDEX	
PLOT BOUNDARY	Black
ABUTTING ROAD	Green
PROPOSED CONSTRUCTION	Red
COMMON PLOT	Yellow
ROAD WIDENING AREA	Blue
EXISTING (To be retained)	Orange
EXISTING (To be demolished)	Light Blue

Building USE/SUBUSE Details

Building Name	Building Use	Building SubUse	Building Structure
A(SONI DEVI, DHIRAJ KUMAR AND SURAJ KUMAR)	Residential	Residential Bldg/Apartment	Non-Highrise

FAR & Tenement Details (Table 4c-1)

Building	No. of Same Bldg	Total Built Up Area (Sq.mt.)	Proposed FAR Area (Sq.mt.) Resi.	Total FAR Area (Sq.mt.)	Total Consumed Additional FAR Area (Sq.mt.)	Tnmt (No.)
A(SONI DEVI, DHIRAJ KUMAR AND SURAJ KUMAR)	1	113.93	113.93	113.93	113.93	01
Grand Total :	1	113.93	113.93	113.93	113.93	01

Buildingwise Floor FAR Details

Floor Name	Building Name		Total	
	A(SONI DEVI, DHIRAJ KUMAR AND SURAJ KUMAR)	Proposed FAR Area (Sq.mt.)	Total Proposed Built Up Area (Sq.mt.)	Total FAR Area (Sq.mt.)
Ground Floor	53.14	53.14	53.14	53.14
First Floor	60.79	60.79	60.79	60.79
Terrace Floor	0.00	0.00	0.00	0.00
Total :	113.93	113.93	113.93	113.93

Proposal Basic Information

Proposal File No.	AMC/BP/0030/W22/2018
Owner Name	(1) MRS. SONI DEVI (2) MR. DHIRAJ KUMAR VERMA (3) SURAJ KUMAR VERMA
Khata No	110(NEW), 48(OLD)
Plot No	2481(NEW), 456(OLD)
Village Name	ASANGI
Use	Residential
SubUse	Bungalow/ Dwelling / Non Apartment

LTP NAME AND SIGNATURE	STRUCTURAL ENG'S NAME AND SIGNATURE	BUILDER NAME AND SIGNATURE	DIGITAL SIGNATURE
MOHAMMAD BELAL NASIR AMC/DFTMN/001/2018			

Proposal Basic Information	
Proposal File No.	AMC/BP/0030/W22/2018
Owner Name	(1) MRS. SONI DEVI (2) MR. DHIRAJ KUMAR VERMA (3) SURAJ KUMAR VERMA
Khata No	110(NEW), 48(OLD)
Plot No	2481(NEW), 456(OLD)
Village Name	ASANGI
Use	Residential
SubUse	Bungalow/ Dwelling / Non Apartment

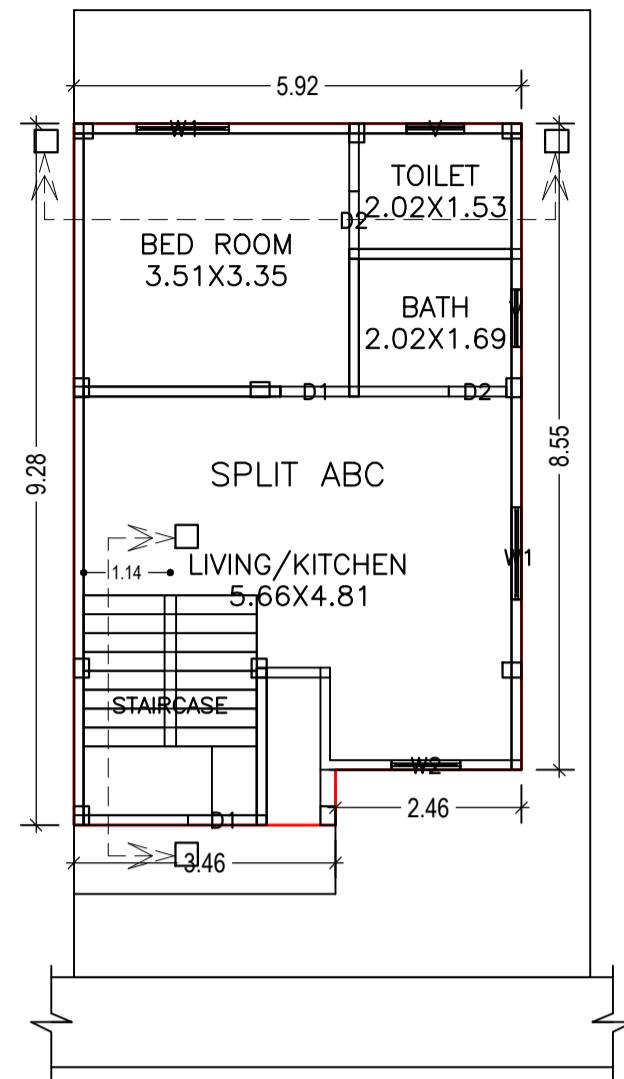

GROUND FLOOR PLAN  
(Proposed)  
(SCALE 1:100)

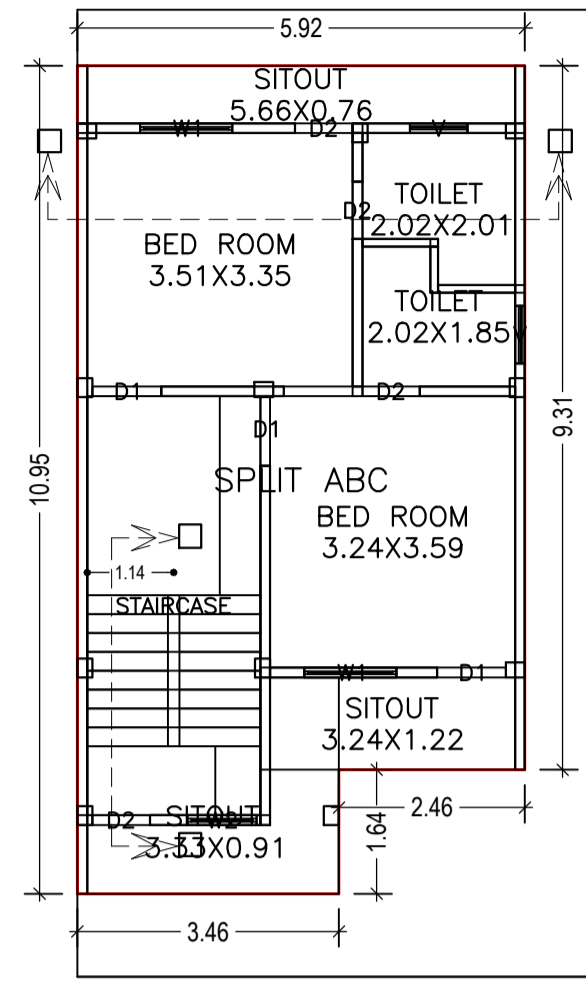

FIRST FLOOR PLAN  
(Proposed)  
(SCALE 1:100)

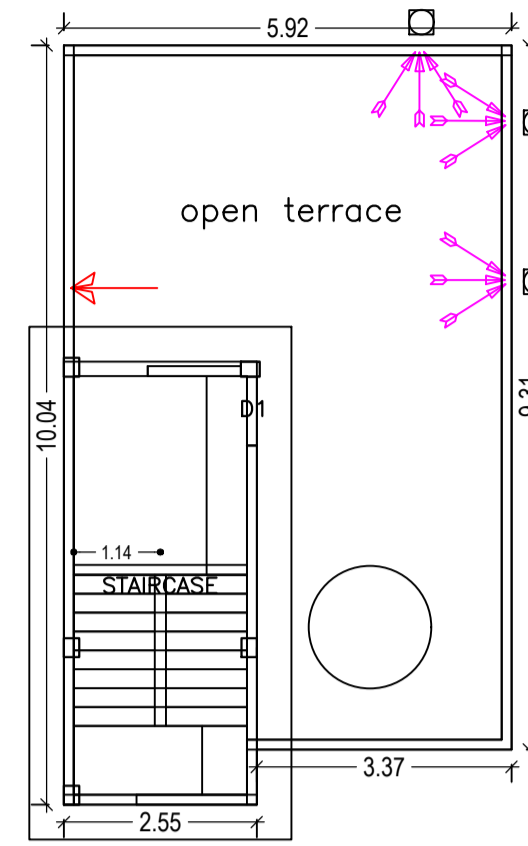

TERRACE FLOOR PLAN  
(SCALE 1:100)

Building :A(SONI DEVI ,DHIRAJ KUMAR AND SURAJ KUMAR)

Floor Name	Total Built Up Area (Sq.mt.)	Proposed FAR Area (Sq.mt.) Resi.	Total Consumed Additional FAR Area (Sq.mt.)	Tnmt (No.)
Ground Floor	53.14		53.14	01
First Floor	60.79	60.79	60.79	00
Terrace Floor	0.00	0.00	0.00	
Total Number of Same Buildings	1			
Total :	113.93	113.93	113.93	01

UnitBUA Table for Building :A(SONI DEVI ,DHIRAJ KUMAR AND SURAJ KUMAR)

FLOOR	Name	UnitBUA Type	UnitBUA Area	Carpet Area	No. of Rooms	No. of Tenement
GROUND FLOOR PLAN	SPLIT ABC	FLAT	113.93	104.10	4	1
FIRST FLOOR PLAN	SPLIT ABC	FLAT	0.00	0.00	7	0
Total:	-	-	113.93	104.10	11	1

SCHEDULE OF DOOR:

BUILDING NAME	NAME	LENGTH	HEIGHT	NOS
A(SONI DEVI ,DHIRAJ KUMAR AND SURAJ KUMAR)	D2	0.76	2.13	06
A(SONI DEVI ,DHIRAJ KUMAR AND SURAJ KUMAR)	D1	0.91	2.13	04

SCHEDULE OF WINDOW/VENTILATION:

BUILDING NAME	NAME	LENGTH	HEIGHT	NOS
A(SONI DEVI ,DHIRAJ KUMAR AND SURAJ KUMAR)	V	0.76	0.61	04
A(SONI DEVI ,DHIRAJ KUMAR AND SURAJ KUMAR)	W2	0.91	1.22	02
A(SONI DEVI ,DHIRAJ KUMAR AND SURAJ KUMAR)	W1	1.22	1.22	04

LTP NAME AND SIGNATURE	STRUCTURAL ENG'S NAME AND SIGNATURE	BUILDER NAME AND SIGNATURE	DIGITAL SIGNATURE
MOHAMMAD BELAL NASIR AMC/DFTMN/0001/2018			

Proposal Basic Information	
Proposal File No.	AMC/BP/0030/W22/2018
Owner Name	(1) MRS. SONI DEVI (2) MR. DHIRAJ KUMAR VERMA (3) SURAJ KUMAR VERMA
Khata No	110(NEW), 48(OLD)
Plot No	2481(NEW), 456(OLD)
Village Name	ASANGI
Use	Residential
SubUse	Bungalow/ Dwelling / Non Apartment

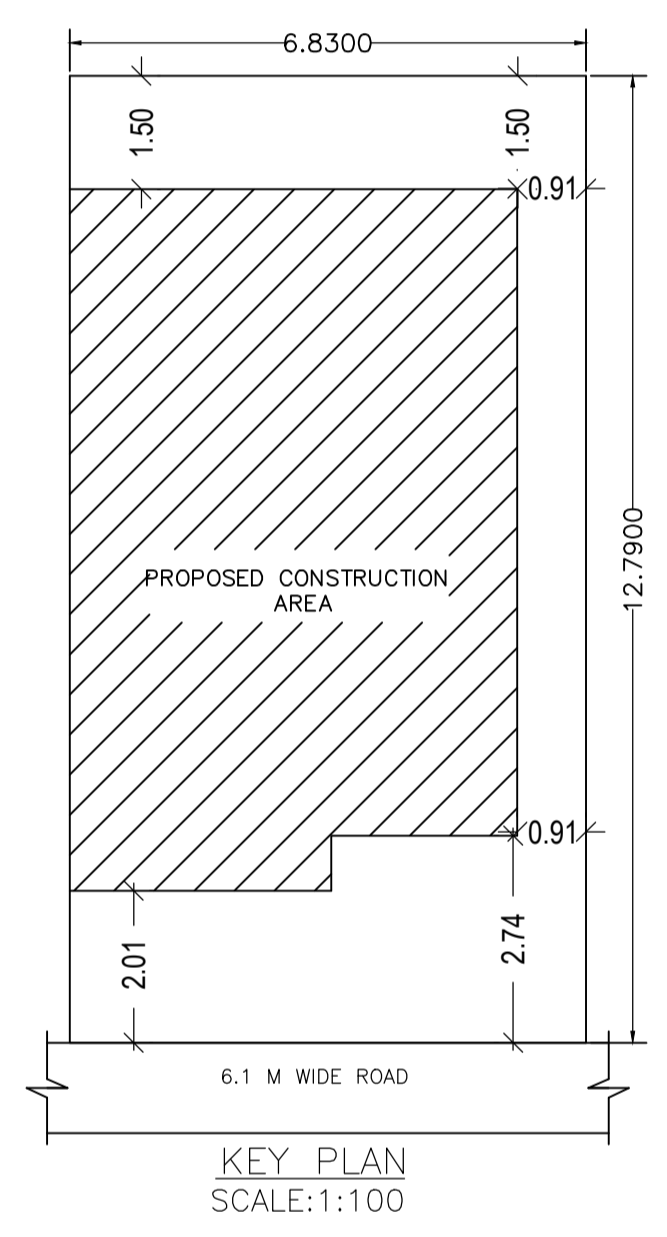
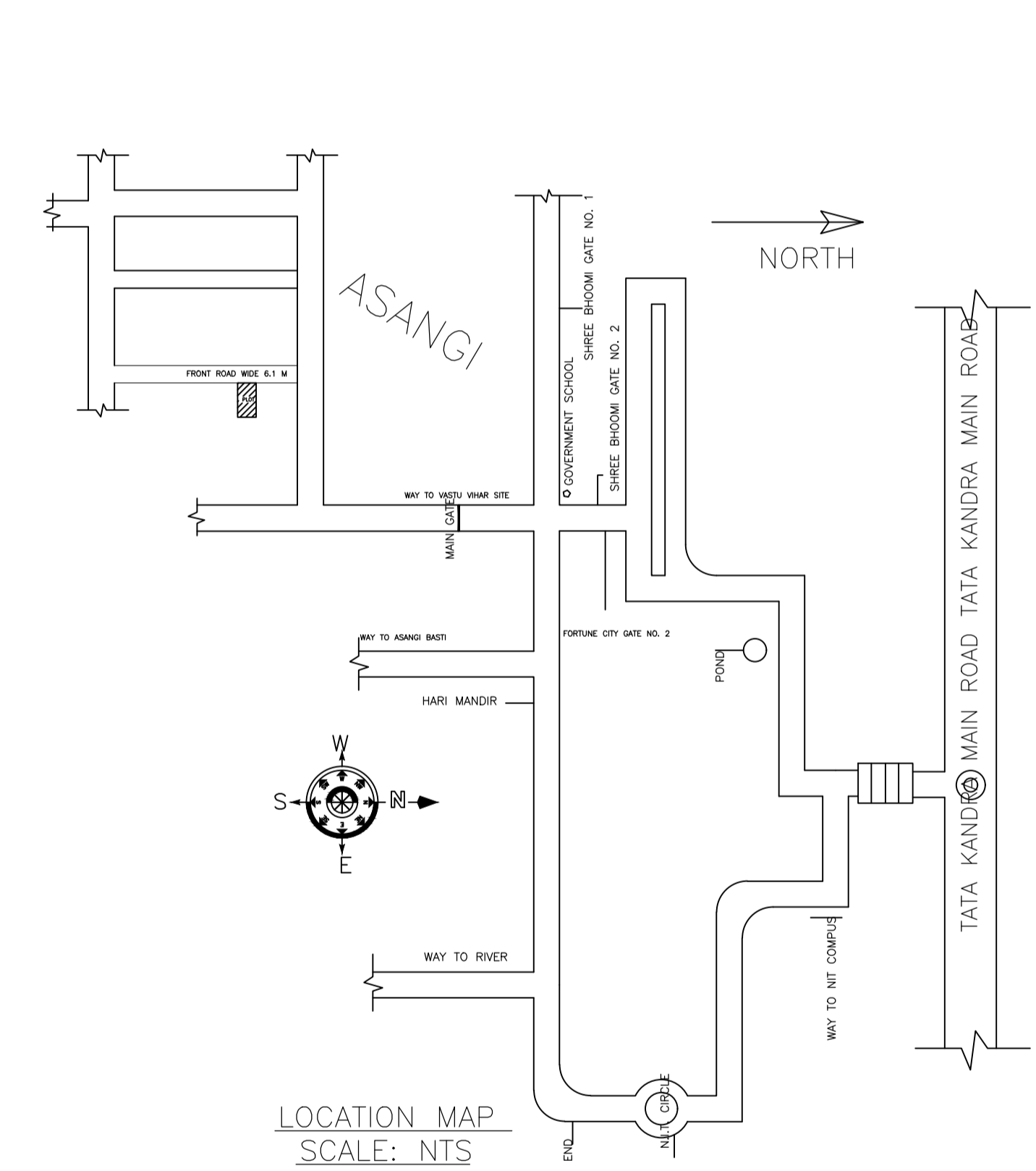
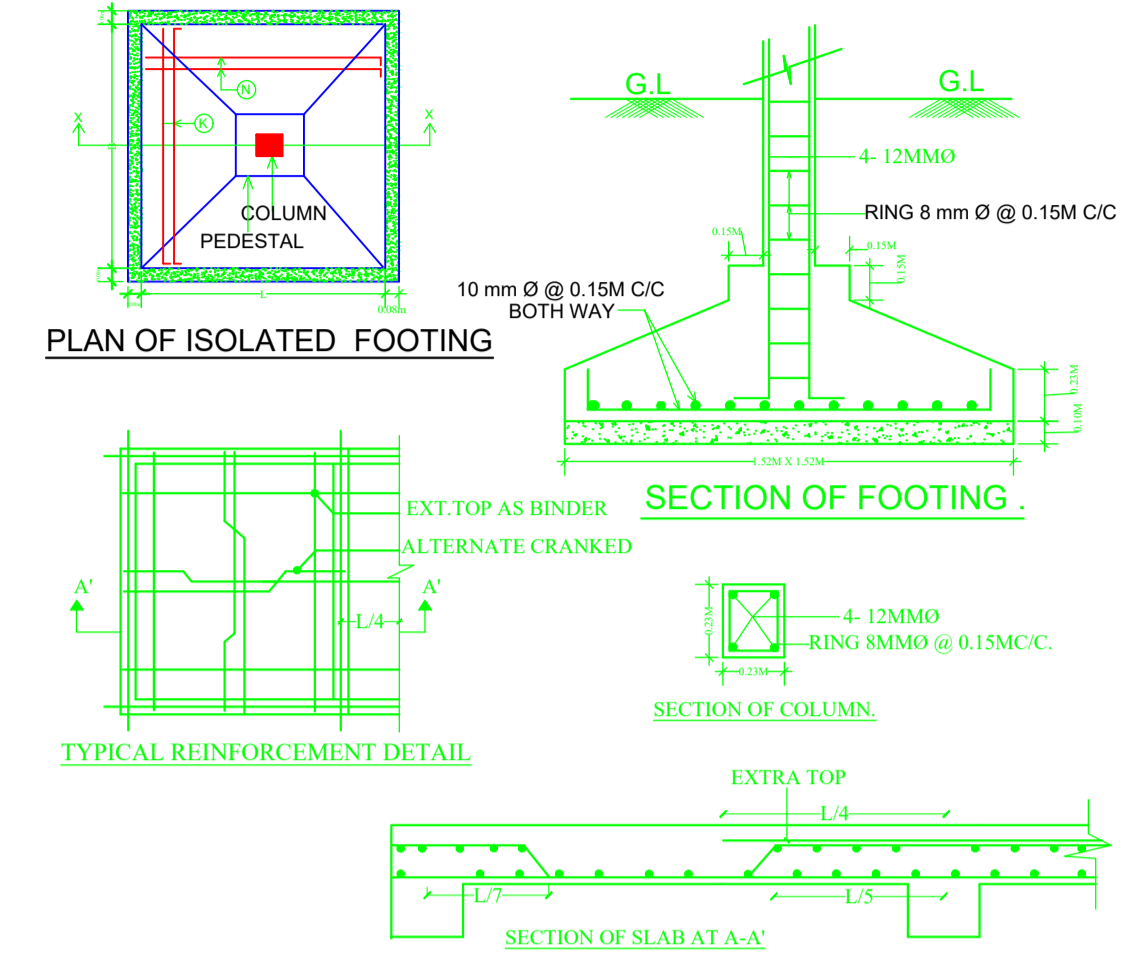
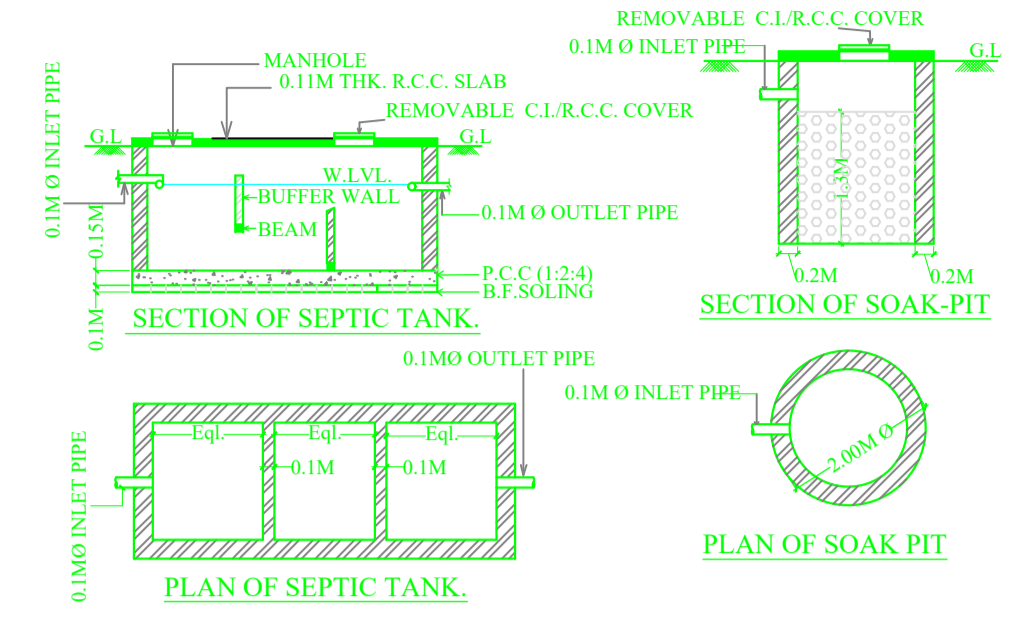
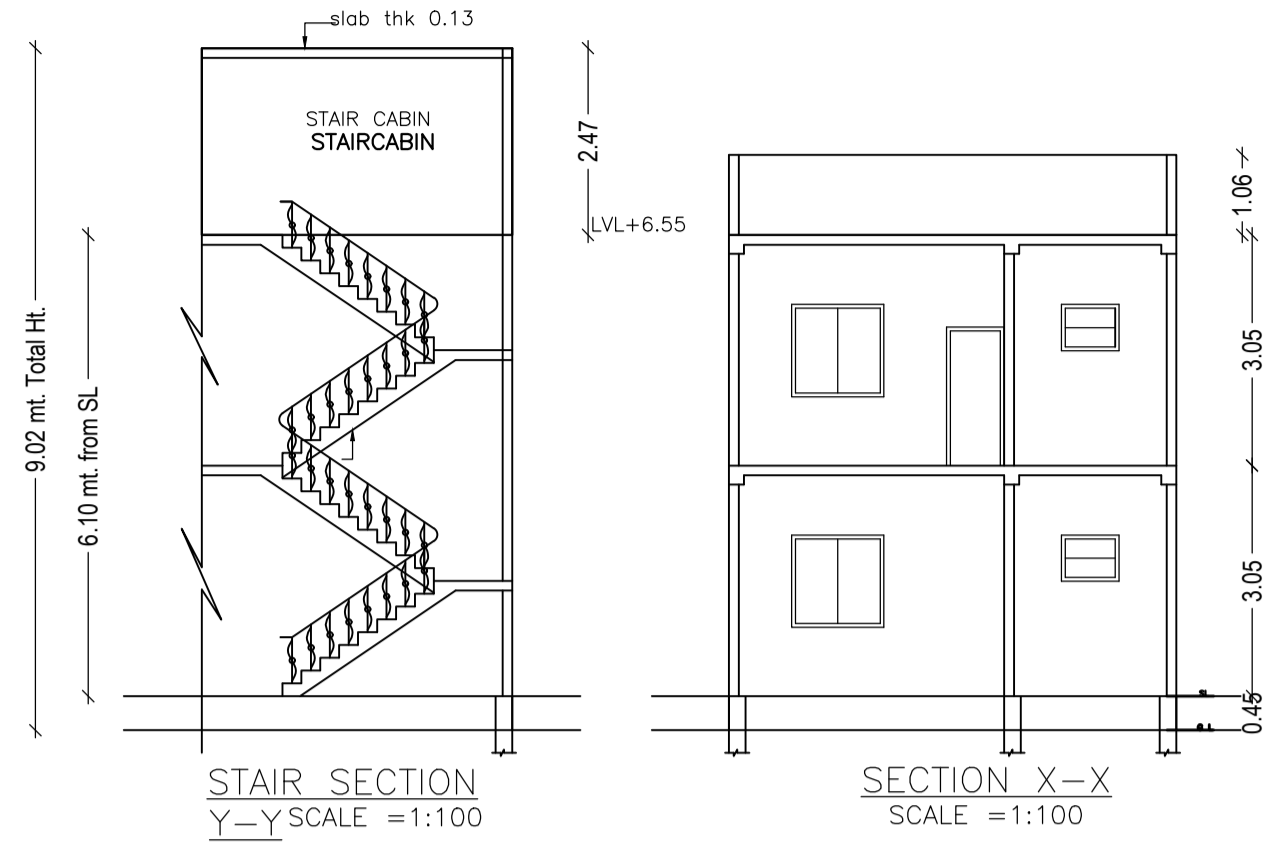

LTP NAME AND SIGNATURE	STRUCTURAL ENG'S NAME AND SIGNATURE	BUILDER NAME AND SIGNATURE	DIGITAL SIGNATURE
MOHAMMAD BELAL NASIR AMC/DFTMN/0001/2018			