

SITE PLAN
SCALE:1:100

site Plan

AREA STATEMENT		VERSION NO.: 1.0.30
ADITYAPUR MUNICIPAL CORPORATION		
PROJECT DETAIL:		
Region : JHARKHAND URBAN LOCAL BODIES	Plot Use: Residential	
District: EAST SINGHBHUM	Plot SubUse: Bungalow/ Dwelling / Non Apartment	
	Plot/Nearby/Religious Structure: NA	
Inward_No: AMC/BP/0026/W22/2018	Plot/SubPlot No: 2481(NEW), 456(OLD)	
	North: -	
	South: -	
	East: -	
	West: -	
Project Type: Building Permission		
Location of Development Area: Old Area		
AREA DETAILS:		SQ.MT.
AREA OF PLOT (Minimum)	(A)	74.37
NET AREA OF PLOT(Gross Plot Area - Deduction from Gross Plot area)	(A-Deductions)	74.37
Deduction for Balance Plot Area(from Gross Plot Area)		
Common Plot		5.61
Total		5.61
BALANCE AREA OF PLOT(Net Plot Area - Recreational/Amenity space)	(A-Deductions)	68.76
PLOT AREA FOR COVERAGE(Net Plot Area)	(A-Deductions)	74.37
Plot Area for FAR (Net Plot Area - Road/Widening Area)	(A-Deductions)	74.37
COVERAGE CHECK		
Permissible Coverage area (70.00 %)		52.06
Proposed Coverage Area (59.92 %)		44.56
Total Prop. Coverage Area (59.92 %)		44.56
Balance coverage area (10.08 %)		7.50
FAR CHECK		
Perm. FAR Area (2.50)		185.93
Total Perm. FAR area		185.93
Residential FAR		95.51
Proposed FAR Area		95.51
Total Proposed FAR Area		95.51
Consumed FAR (Factor)		1.28
Balance FAR Area		90.42
BUILT UP AREA CHECK		
Total Proposed BuiltUp Area		95.51
ARCHITECT (Regd)	MOHAMMAD BELAL NASIR	
ENGINEER (Regd)		
SUPERVISOR (Regd)		
OWNER (Regd)	MRS. MADHU SINHA	
DEVELOPMENT AUTHORITY LOCAL BODY		

COLOR INDEX	
PLOT BOUNDARY	Black
ABUTTING ROAD	Green
PROPOSED CONSTRUCTION	Red
COMMON PLOT	Yellow
ROAD WIDENING AREA	Blue
EXISTING (To be retained)	Light Blue
EXISTING (To be demolished)	Orange

Building USE/SUBUSE Details

Building Name	Building Use	Building SubUse	Building Structure
A (MADHU SINHA)	Residential	Residential Bldg/Apartment	Non-Highrise

FAR & Tenement Details (Table 4c-1)

Building	No. of Same Bldg	Total Built Up Area (Sq.mt.)	Proposed FAR Area (Sq.mt.) Resil.	Total FAR Area (Sq.mt.)	Total Consumed Additional FAR Area (Sq.mt.)	Tnmt (No.)
A (MADHU SINHA)	1	95.51	95.51	95.51	95.51	01
Grand Total :	1	95.51	95.51	95.51	95.51	01

Buildingwise Floor FAR Details

Floor Name	Building Name A (MADHU SINHA)		Total	
	Proposed Built Up Area (Sq.mt.)	Proposed FAR Area (Sq.mt.)	Total Proposed Built Up Area (Sq.mt.)	Total FAR Area (Sq.mt.)
Ground Floor	44.56	44.56	44.56	44.56
First Floor	50.95	50.95	50.95	50.95
Terrace Floor	0.00	0.00	0.00	0.00
Total :	95.51	95.51	95.51	95.51

Proposal Basic Information

Proposal File No.	AMC/BP/0026/W22/2018
Owner Name	MRS. MADHU SINHA
Khata No	110(NEW), 48(OLD)
Plot No	2481(NEW), 456(OLD)
Village Name	ASANGI
Use	Residential
SubUse	Bungalow/ Dwelling / Non Apartment

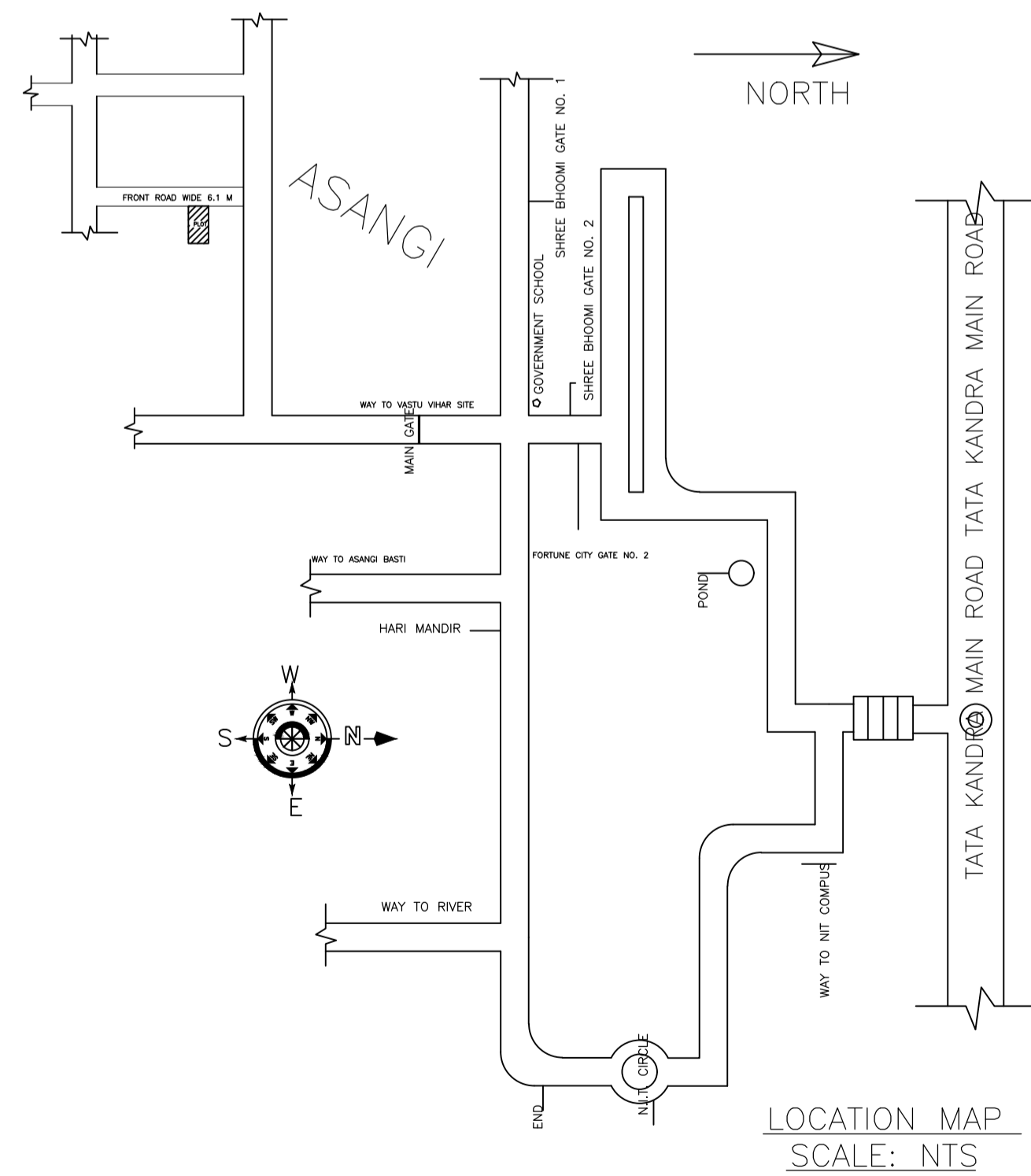

LOCATION MAP
SCALE: NTS

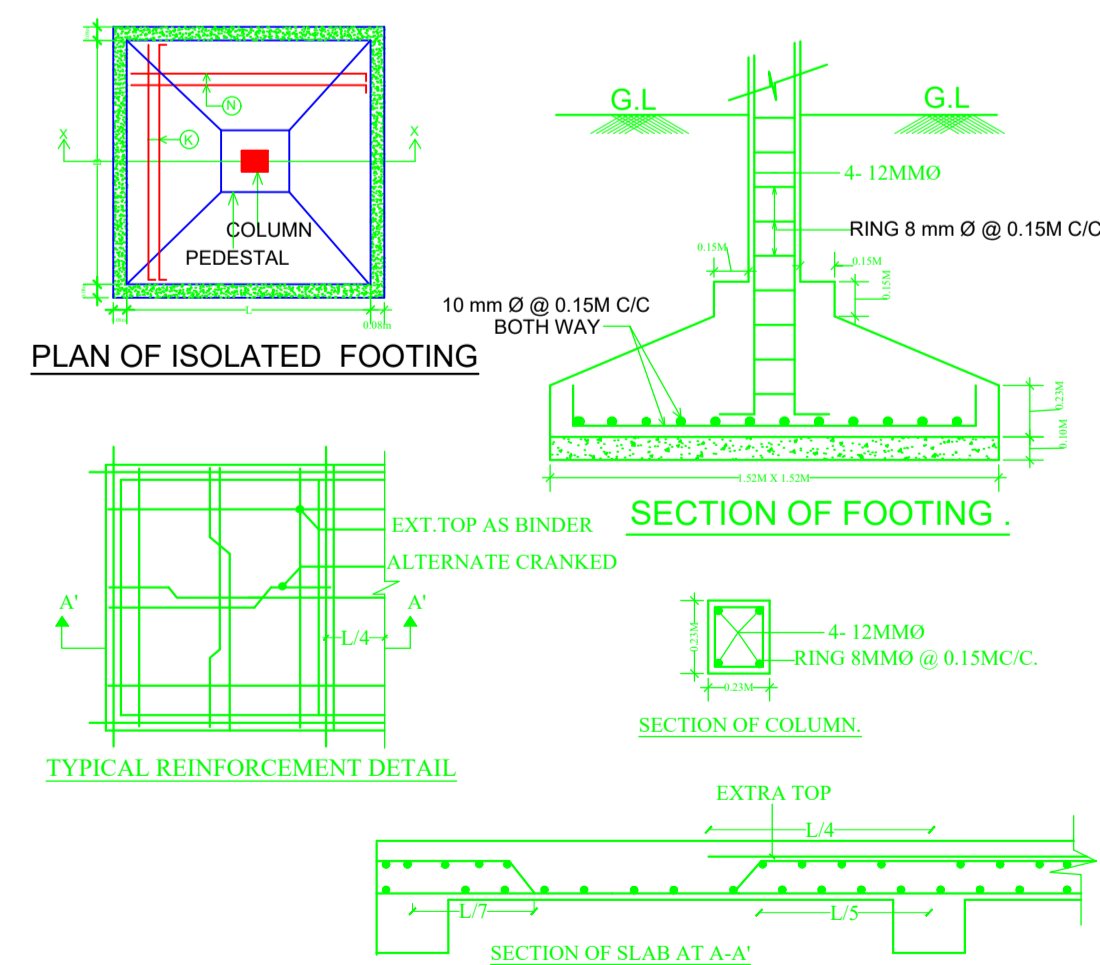
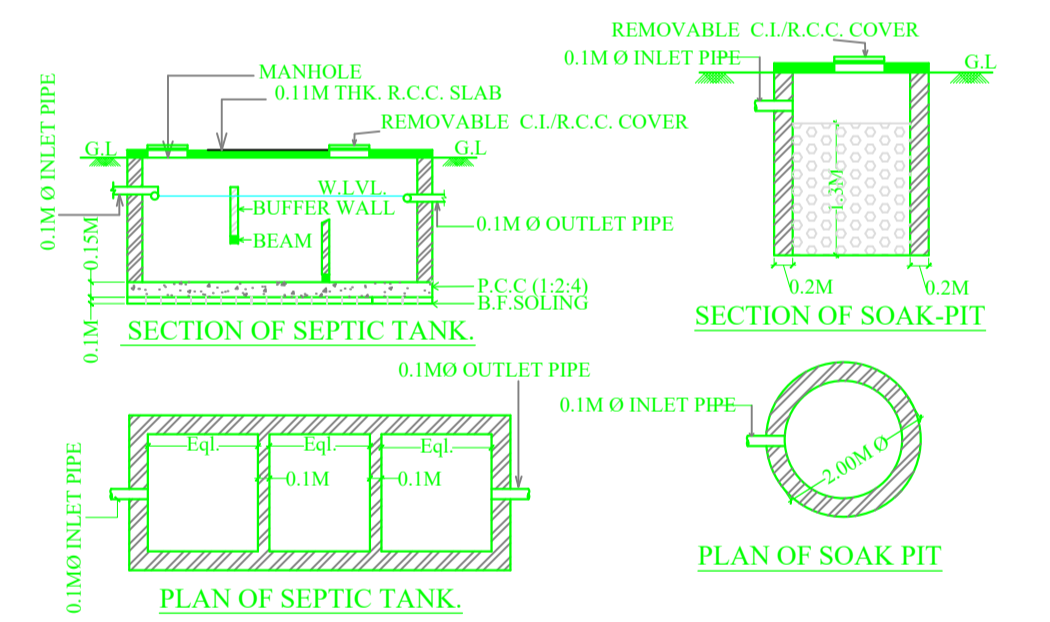

LTP NAME AND SIGNATURE	STRUCTURAL ENG'S NAME AND SIGNATURE	BUILDER NAME AND SIGNATURE	DIGITAL SIGNATURE
MOHAMMAD BELAL NASIR AMC/DFTMN/0001/2018			

Proposal Basic Information	
Proposal File No.	AMC/BP/0026/W22/2018
Owner Name	MRS. MADHU SINHA
Khata No	110(NEW), 48(OLD)
Plot No	2481(NEW), 456(OLD)
Village Name	ASANGI
Use	Residential
SubUse	Bungalow/ Dwelling / Non Apartment

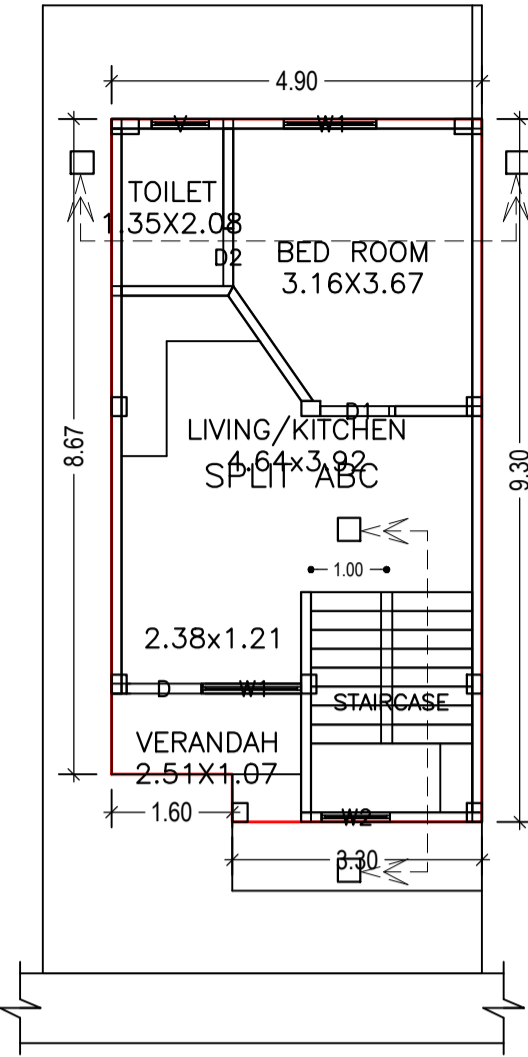

GROUND FLOOR PLAN
(Proposed)
(SCALE 1:100)

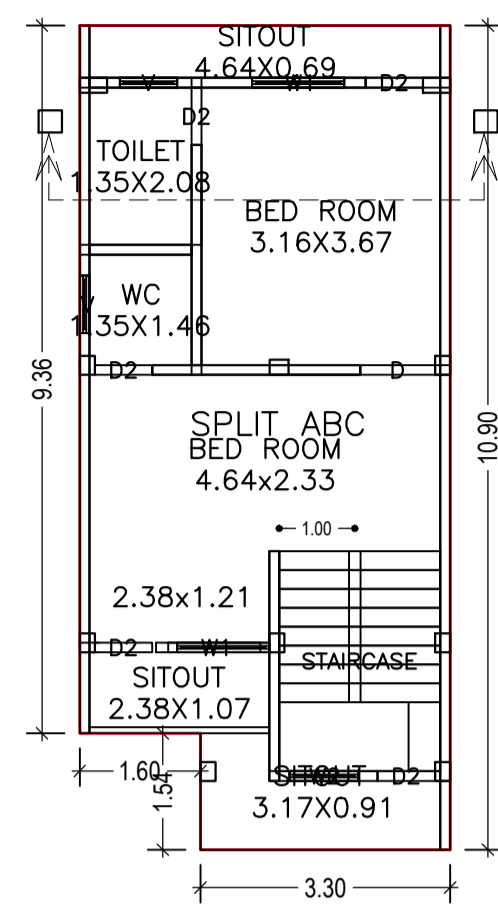

FIRST FLOOR PLAN
(Proposed)
(SCALE 1:100)

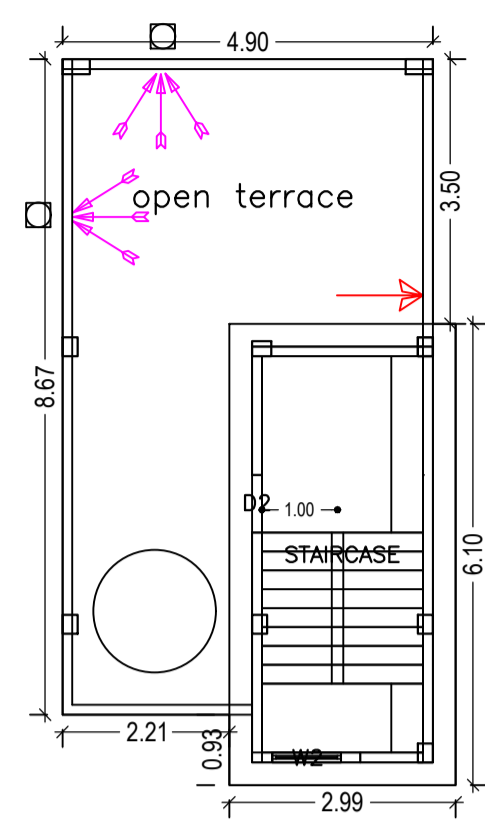

TERRACE FLOOR PLAN
(SCALE 1:100)

Building :A(MADHU SINHA)

Floor Name	Total Built Up Area (Sq.mt.)	Proposed FAR Area (Sq.mt.)	Total FAR Area (Sq.mt.)	Total Consumed Additional FAR Area (Sq.mt.)	Tnmt (No.)
Ground Floor		44.56		44.56	01
First Floor			50.95		00
	0.00	0.00	0.00		00
Total:	95.51	95.51		95.51	01
Total Number of Same Buildings	1				
Total:	95.51	95.51	95.51	95.51	01

SCHEDULE OF DOOR:

BUILDING NAME	NAME	LENGTH	HEIGHT	NOS
A(MADHU SINHA)	D2	0.76	2.13	06
A(MADHU SINHA)	D	0.99	2.13	02
A(MADHU SINHA)	D1	0.99	2.13	01

SCHEDULE OF WINDOW/VENTILATION:

BUILDING NAME	NAME	LENGTH	HEIGHT	NOS
A(MADHU SINHA)	V	0.76	0.61	03
A(MADHU SINHA)		0.91	1.22	03
A(MADHU SINHA)	W1	1.22	1.22	
A(MADHU SINHA)	W1		1.22	01

UnitBUA Table for Building :A(MADHU SINHA)

FLOOR	Name	UnitBUA Type	UnitBUA Area	Carpet Area	No. of Rooms	No. of Tenement
GROUND FLOOR PLAN	SPLIT ABC	FLAT	89.78	86.90	4	1
FIRST FLOOR PLAN	SPLIT ABC	FLAT	0.00	0.00	7	0
Total:	-	-	89.78	86.90	11	1

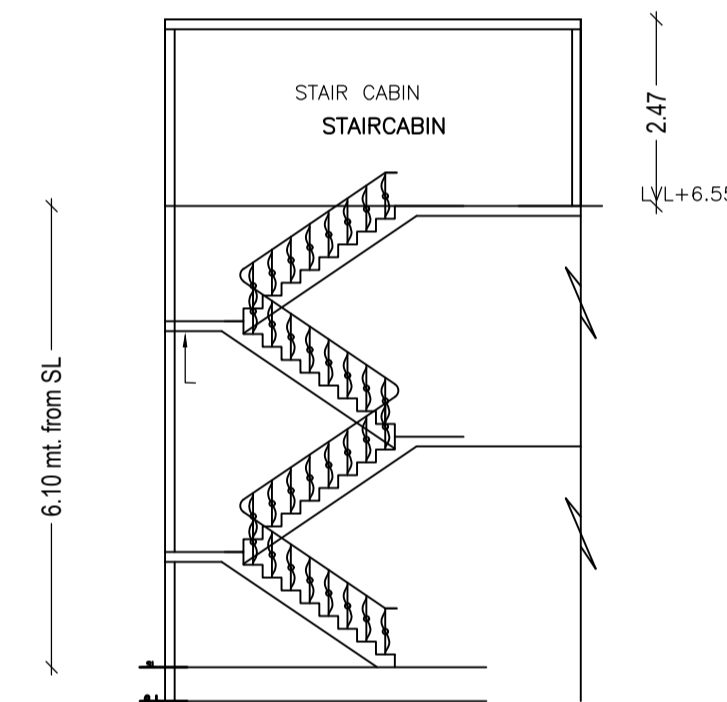

STAIR SECTION
Y-Y SCALE = 1:100

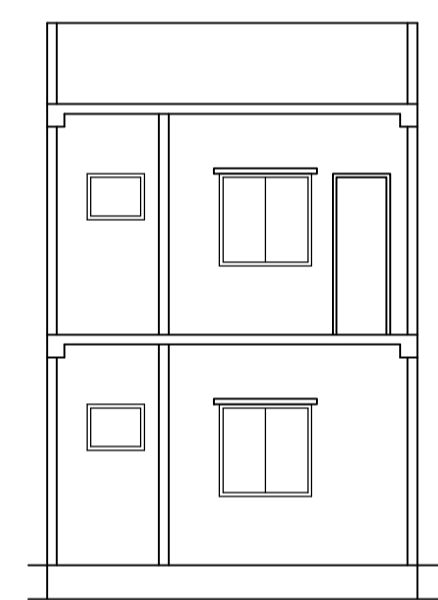

SECTION X-X
SCALE = 1:100

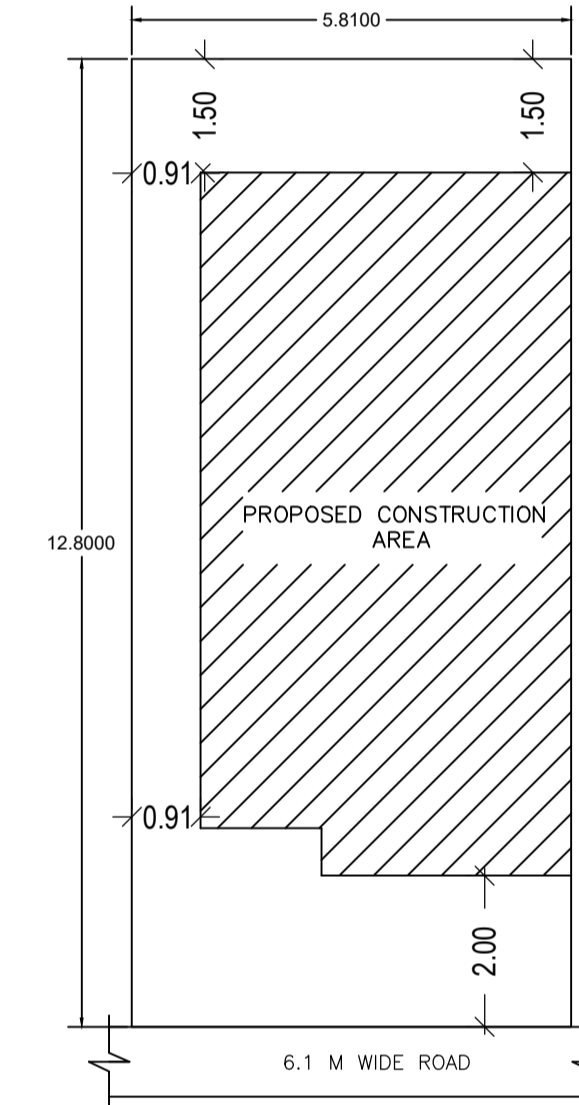

KEY PLAN
SCALE:1:100

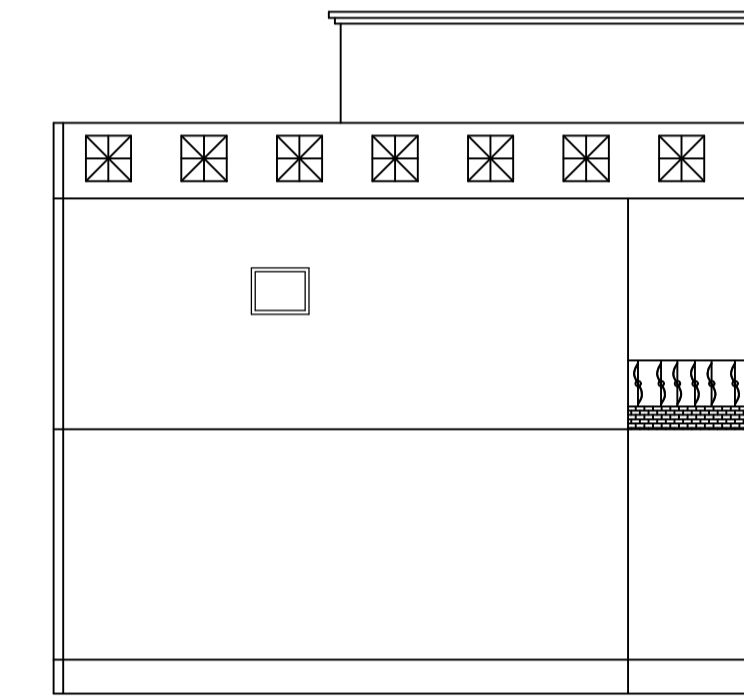

SIDE ELEVATION
SCALE = 1:100

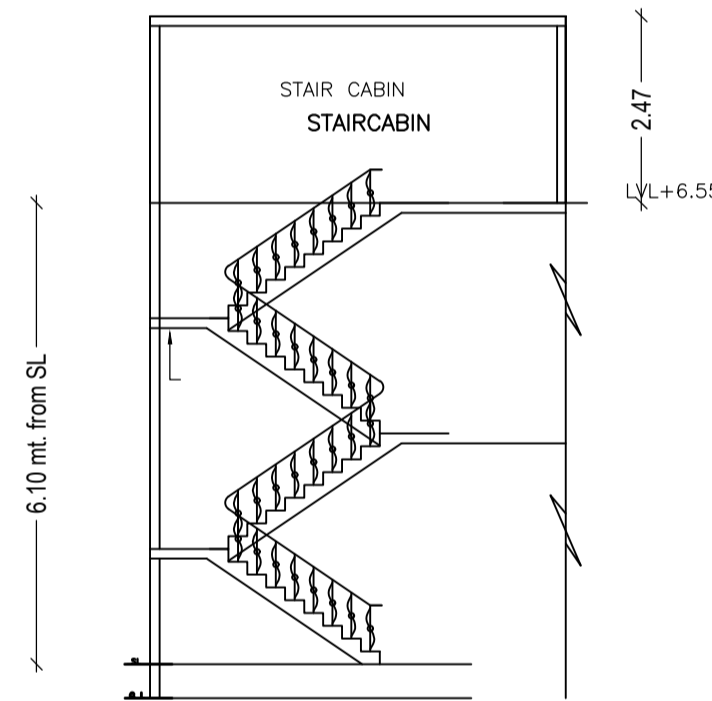

STAIR SECTION
Y-Y SCALE = 1:100

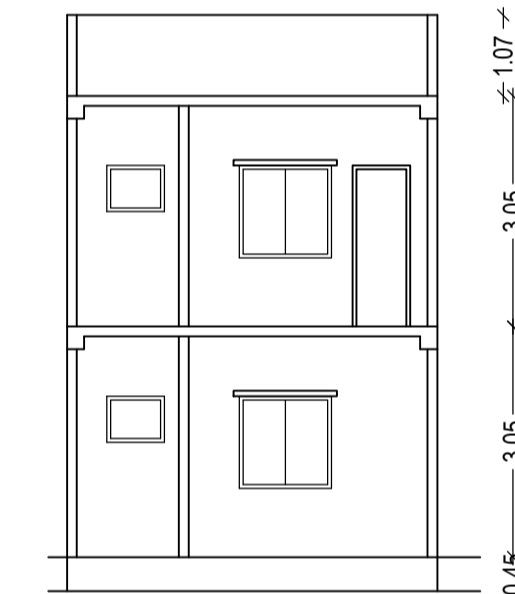

SECTION X-X
SCALE = 1:100

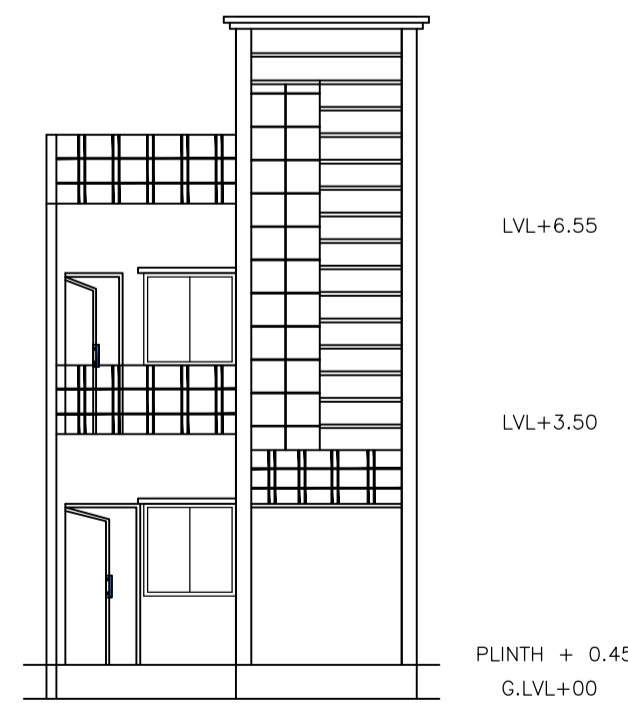

FRONT ELEVATION
SCALE = 1:100

LTP NAME AND SIGNATURE	STRUCTURAL ENG'S NAME AND SIGNATURE	BUILDER NAME AND SIGNATURE	DIGITAL SIGNATURE
MOHAMMAD BELAL NASIR AMC/DFTMN/0001/2018			

Proposal Basic Information	
Proposal File No.	AMC/BP/0026/W22/2018
Owner Name	MRS. MADHU SINHA
Khata No	110(NEW), 48(OLD)
Plot No	2481(NEW), 456(OLD)
Village Name	ASANGI
Use	Residential
SubUse	Bungalow/ Dwelling / Non Apartment

LTP NAME AND SIGNATURE	STRUCTURAL ENG'S NAME AND SIGNATURE	BUILDER NAME AND SIGNATURE	DIGITAL SIGNATURE
MOHAMMAD BELAL NASIR AMC/DFTMN/001/2018			