

SITE PLAN
SCALE-1:100

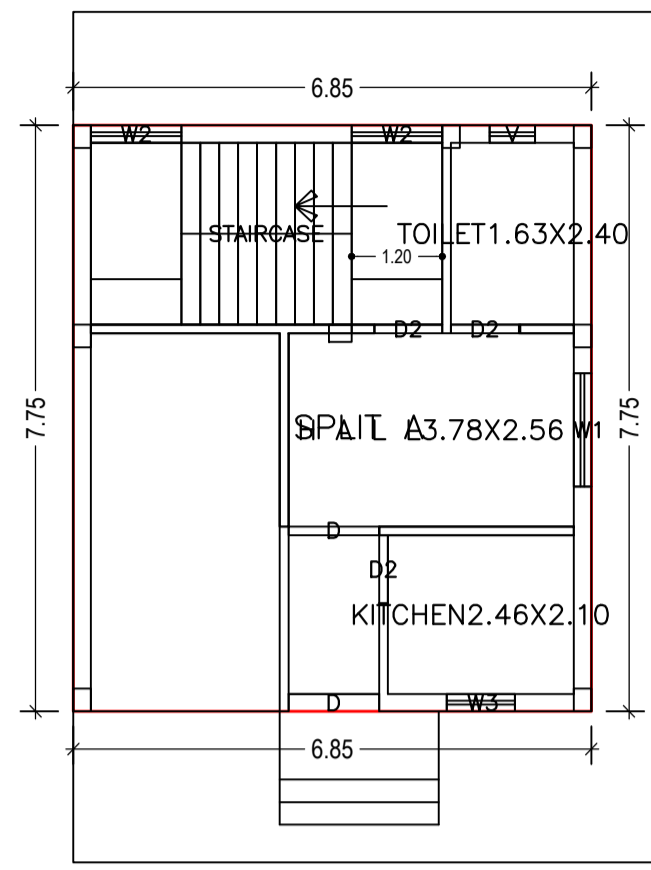

GROUND FLOOR PLAN
(Proposed)
SCALE 1:100

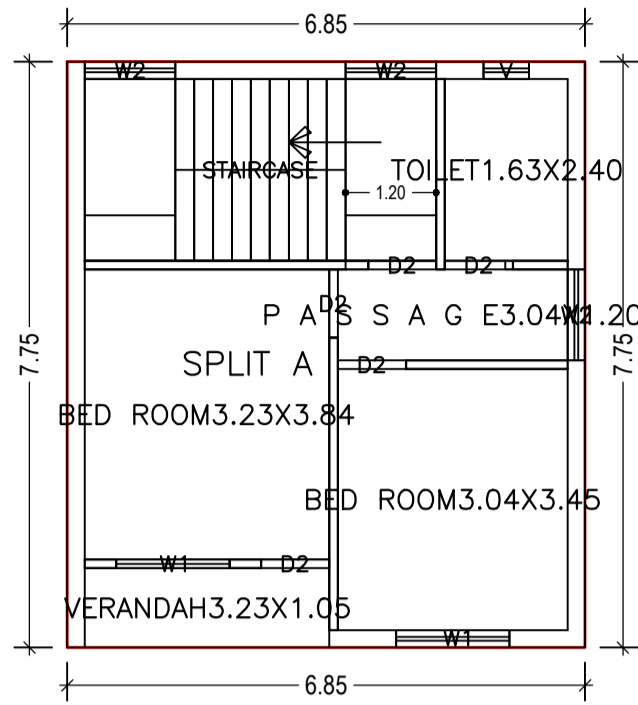

FIRST FLOOR PLAN
(Proposed)
SCALE 1:100

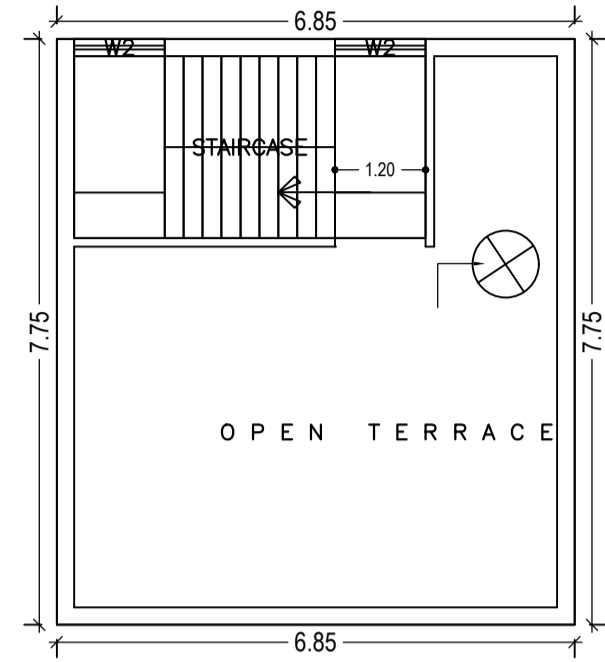

TERRACE FLOOR PLAN
(SCALE 1:100)

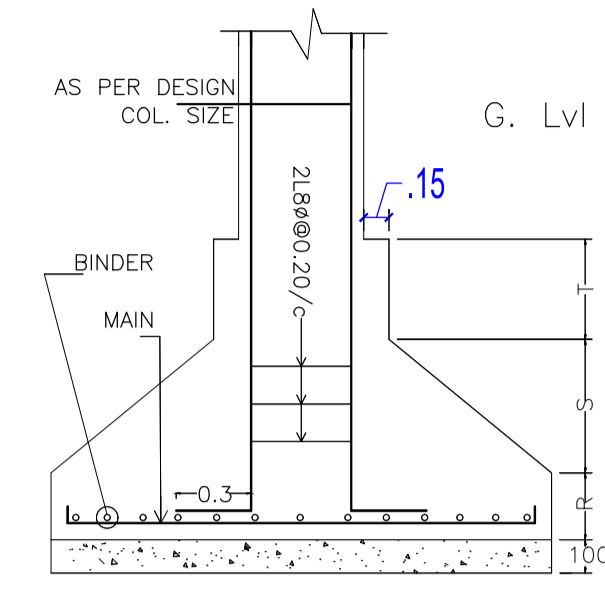

DETAIL OF COLUMN & FOOTING

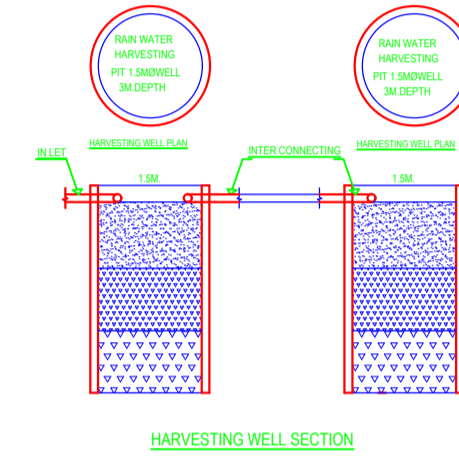

HARVESTING WELL SECTION

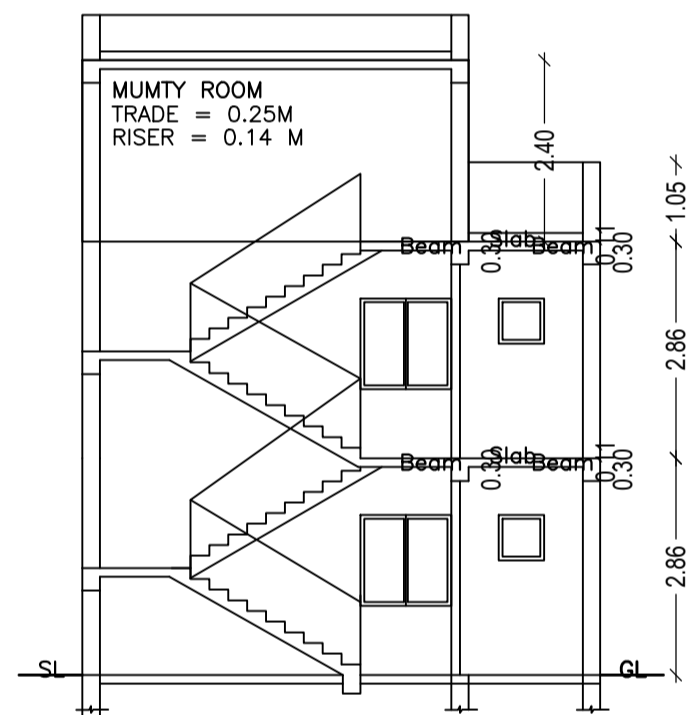

SCALE-1:100

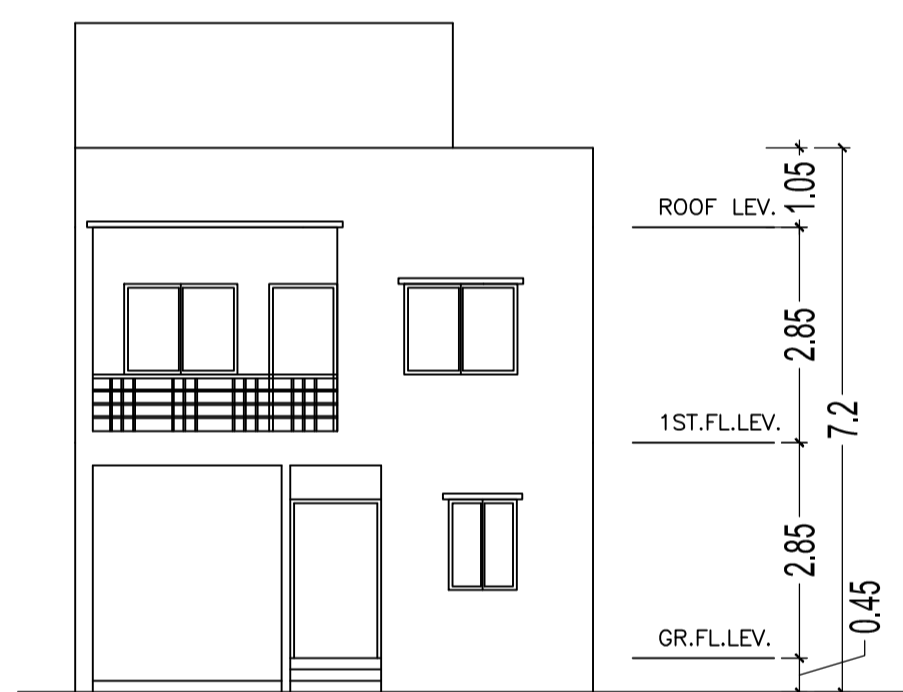

FRONT ELEVATION
SCALE-1:100

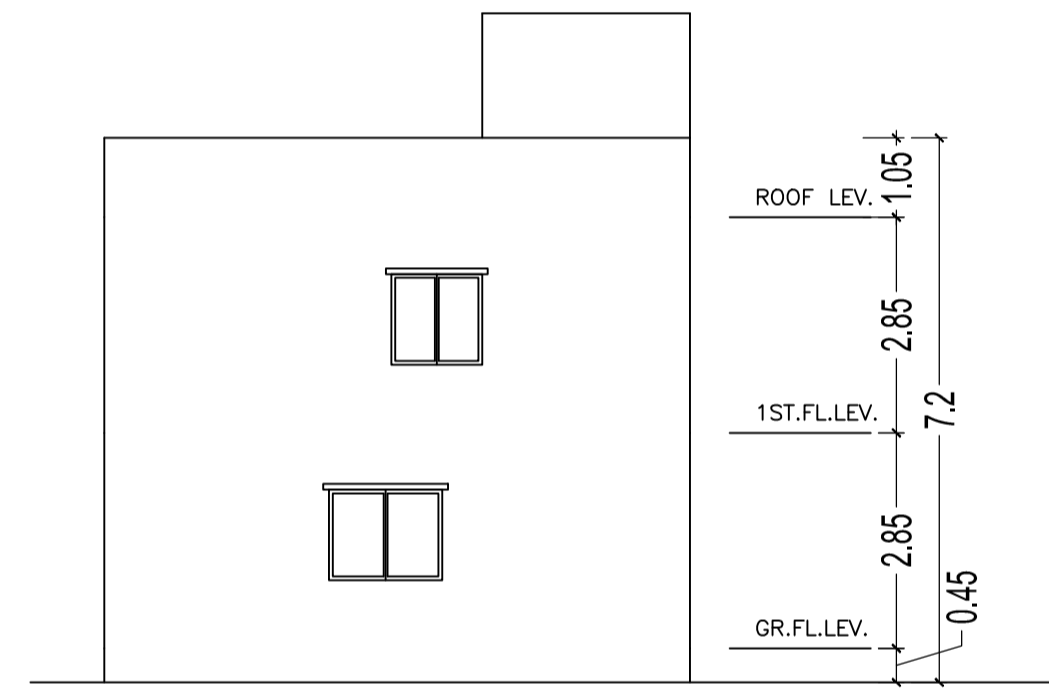

SIDE ELEVATION
SCALE-1:100

Proposal Basic Information	
Proposal File No.	AMC/BP/0047/W32/2018
Owner Name	Akhilesh Kumar Tiwary
Khata No	Old-48, New-178
Plot No	Old-614, New-1649
Village Name	KULUPTANGA
Use	Residential
SubUse	Bungalow/ Dwelling / Non Apartment

AREA STATEMENT		VERSION NO.:	1.0.37
ADITYAPUR MUNICIPAL CORPORATION		VERSION DATE:	29/04/2019
PROJECT DETAIL:			
Region: JHARKHAND URBAN LOCAL BODIES	Plot Use:	Residential	
District: EAST SINGHBHUM	Plot SubUse:	Bungalow/ Dwelling / Non Apartment	
Authority: ADITYAPUR MUNICIPAL CORPORATION	PlotNearbyReligiousStructure:	NA	
Inward No: AMC/BP/0047/W32/2018	PlotSubPlot No:	Old-614, New-1649	
Application Type: General Proposal			
Project Type: Building Permission			
Nature of Development: New	East: Plot No. -	1652	
Location of Development Area: Old Area	West: Road Width -	5.5	
AREA DETAILS:			
AREA OF PLOT (Minimum)	(A)	87.19	
NET AREA OF PLOT (Gross Plot Area - Deduction from Gross Plot area)	(A-Deductions)	87.19	
Deduction for Balance Plot Area (from Gross Plot Area)			
Common Plot		18.51	
Total		18.51	
BALANCE AREA OF PLOT (Net Plot Area - Recreational/Amenity space)	(A-Deductions)	68.68	
PLOT AREA FOR COVERAGE (Net Plot Area)	(A-Deductions)	87.19	
Plot Area for FAR (Net Plot Area + Road Widening Area)	(A-Deductions)	87.19	
COVERAGE CHECK			
Permissible Coverage area (70.00 %)		61.03	
Proposed Coverage Area (60.89 %)		53.09	
Total Prop. Coverage Area (60.89 %)		53.09	
Balance coverage area (9.11 %)		7.94	
FAR CHECK			
Perm. FAR Area (1.80)		156.94	
Total Perm. FAR area		156.94	
Residential FAR		106.18	
Proposed FAR Area		106.18	
Total Proposed FAR Area		106.18	
Consumed FAR (Factor)		1.22	
Balance FAR Area		50.76	
BUILT UP AREA CHECK			
Total Proposed BuiltUp Area		106.18	
ARCHITECT (Regd)		L. K. SUMAN	
ENGINEER (Regd)			
SUPERVISOR (Regd)			
OWNER (Regd)		Akhilesh Kumar Tiwary	
DEVELOPMENT AUTHORITY		LOCAL BODY	

COLOR INDEX	
PLOT BOUNDARY	Black
ABUTTING ROAD	Red
PROPOSED CONSTRUCTION	Green
COMMON PLOT	Yellow
ROAD WIDENING AREA	Blue
EXISTING (To be retained)	Orange
EXISTING (To be demolished)	Grey

Buildingwise Floor FAR Details

Floor Name	Building Name A (SRI AKHILESH KUMAR TIWARY)		Total	
	Proposed Built Up Area (Sq.mt.)	Proposed FAR Area (Sq.mt.)	Total Proposed Built Up Area (Sq.mt.)	Total FAR Area (Sq.mt.)
Ground Floor	53.09	53.09	53.09	53.09
First Floor	53.09	53.09	53.09	53.09
Terrace Floor	0.00	0.00	0.00	0.00
Total	106.18	106.18	106.18	106.18

FAR & Tenement Details (Table 4c-1)

Building	No. of Same Bldg	Total Built Up Area (Sq.mt.)	Proposed FAR Area (Sq.mt.)	Total FAR Area (Sq.mt.)	Total Consumed Additional FAR Area (Sq.mt.)	Tnmt (No.)
A (SRI AKHILESH KUMAR TIWARY)	1	106.18	106.18	106.18	106.18	01
Grand Total :	1	106.18	106.18	106.18	106.18	01

SCHEDULE OF WINDOW/VENTILATION:

BUILDING NAME	NAME	LENGTH	HEIGHT	NOS
A (SRI AKHILESH KUMAR TIWARY)	V	0.60	0.60	02
A (SRI AKHILESH KUMAR TIWARY)	W3	0.90	1.20	01
A (SRI AKHILESH KUMAR TIWARY)	W2	1.20	1.20	07
A (SRI AKHILESH KUMAR TIWARY)	W1	1.50	1.20	

UnitBUA Table for Building :A (SRI AKHILESH KUMAR TIWARY)

FLOOR	Name	UnitBUA Type	UnitBUA Area	Carpet Area	No. of Rooms	No. of Tenement
GROUND FLOOR PLAN	SPLIT A	FLAT	94.49	91.79	3	1
FIRST FLOOR PLAN	SPLIT A	FLAT	0.00	0.00	5	0
Total:	-	-	94.49	91.79	8	1

Building USE/SUBUSE Details

Building Name	Building Use	Building SubUse	Building Structure
A (SRI AKHILESH KUMAR TIWARY)	Residential	Bungalow/ Dwelling / Non Apartment	Non-Highrise

Building :A (SRI AKHILESH KUMAR TIWARY)

Floor Name	Total Built Up Area (Sq.mt.)	Proposed FAR Area (Sq.mt.)	Total FAR Area (Sq.mt.)	Total Consumed Additional FAR Area (Sq.mt.)	Tnmt (No.)
Ground Floor	53.09	53.09	53.09	53.09	01
First Floor	53.09	53.09	53.09	53.09	00
Terrace Floor	0.00	0.00	0.00	0.00	00
Total	106.18	106.18	106.18	106.18	01
Total Number of Same Buildings	1				
Total :	106.18	106.18	106.18	106.18	01

SCHEDULE OF DOOR:

BUILDING NAME	NAME	LENGTH	HEIGHT	NOS
A (SRI AKHILESH KUMAR TIWARY)	D2	0.90	2.10	08
A (SRI AKHILESH KUMAR TIWARY)	D	1.20	2.10	01

LTP NAME AND SIGNATURE	STRUCTURAL ENG'S NAME AND SIGNATURE	BUILDER NAME AND SIGNATURE	DIGITAL SIGNATURE
L. K. SUMAN AMC/ENG/0021/2016			