

Proposal Basic Information

Proposal File No.	AMC/BP/0043/W32/2019
Owner Name	Technoculture Building Centre Pvt. Ltd.
Khata No	19 (OLD), 61(NEW)
Plot No	587(OLD) & 1688, 1753, 1754, 1755 (NEW)
Village Name	KULUPTANGA
Use	Residential
SubUse	Bungalow/ Dwelling / Non Apartment

AREA STATEMENT	ADITYAPUR MUNICIPAL CORPORATION	VERSION NO.: 1.0.42
PROJECT DETAIL:	Region: JHARKHAND URBAN LOCAL BODIES	VERSION DATE: 29/04/2019
District: EAST SINGHBHUM	Plot Use: Residential	
Authority: ADITYAPUR MUNICIPAL CORPORATION	Plot SubUse: Bungalow/ Dwelling / Non Apartment	
Inward No: AMC/BP/0043/W32/2019	Plot/Nearby/Religious/Structure: NA	
Application Type: General Proposal	North: Plot No. - 1745	
Project Type: Building Permission	Plot/SubPlot No: 587(OLD) & 1688, 1753, 1754, 1755 (NEW)	
Nature of Development: New	South: Plot No. - 1687	
Location of Development Area: Old Area	East: Plot No. - 1752, 1756	
	West: Road Width - 6.1	
AREA OF PLOT (Minimum)	(A)	SQ.MT.
NET AREA OF PLOT(Gross Plot Area - Deduction from Gross Plot area)	(A-Deductions)	75.24
Deduction for Balance Plot Area(from Gross Plot Area)		
Common Plot		5.30
Total		5.30
BALANCE AREA OF PLOT(Net Plot Area - Recreational/Amenity spaces)	(A-Deductions)	69.94
PLOT AREA FOR COVERAGE(Net Plot Area)	(A-Deductions)	75.24
Plot Area for FAR (Net Plot Area + Road/Widening Area)	(A-Deductions)	75.24
COVERAGE CHECK		
Permissible Coverage area (70.00 %)		52.67
Proposed Coverage Area (59.86 %)		45.04
Total Prop. Coverage Area (59.86 %)		45.04
Balance coverage area (10.14 %)		7.63
FAR CHECK		
Perm. FAR Area (2.50)		188.10
Total Perm. FAR area		188.10
Residential FAR		93.54
Proposed FAR Area		93.54
Total Proposed FAR Area		93.54
Consumed FAR (Factor)		1.24
Balance FAR Area		94.56
BUILT UP AREA CHECK		
Total Proposed BuiltUp Area		93.55
ARCHITECT (Regd)		MOHAMMAD BELAL NASIR
ENGINEER (Regd)		
SUPERVISOR (Regd)		
OWNER (Regd)		Technoculture Building Centre Pvt. Ltd.
DEVELOPMENT AUTHORITY		LOCAL BODY

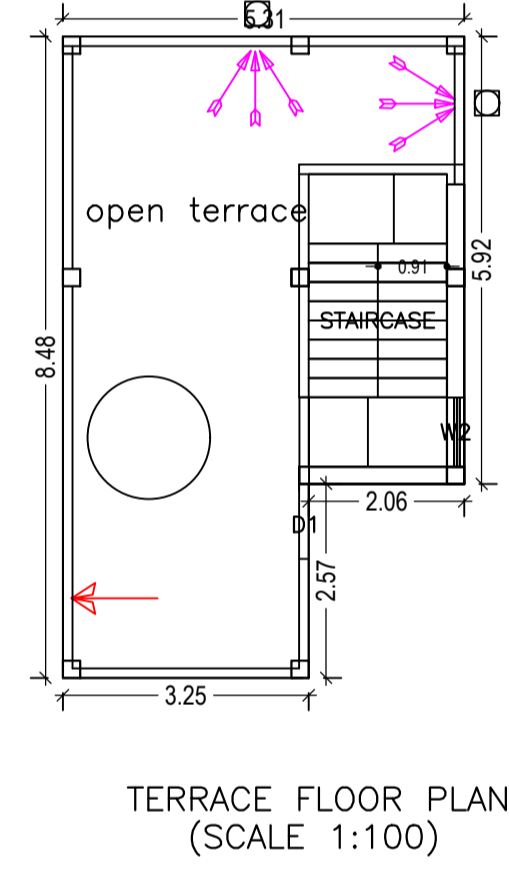
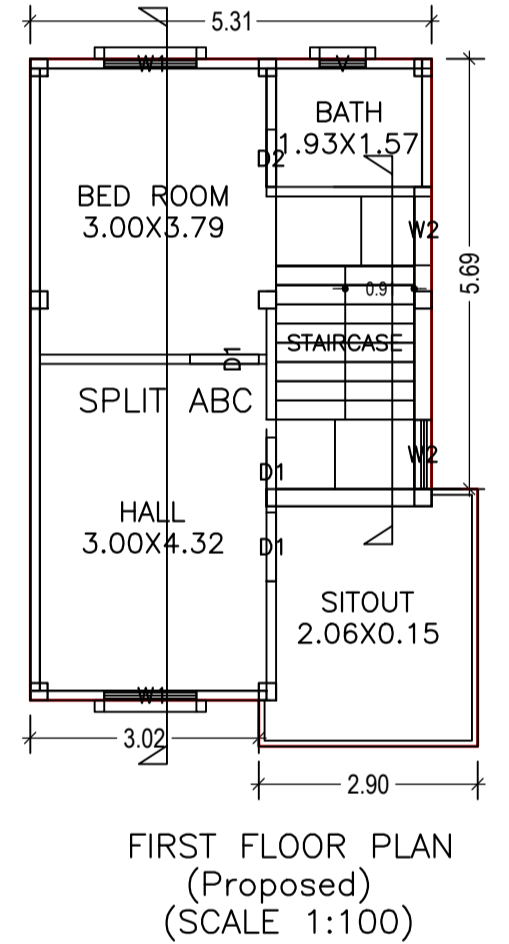
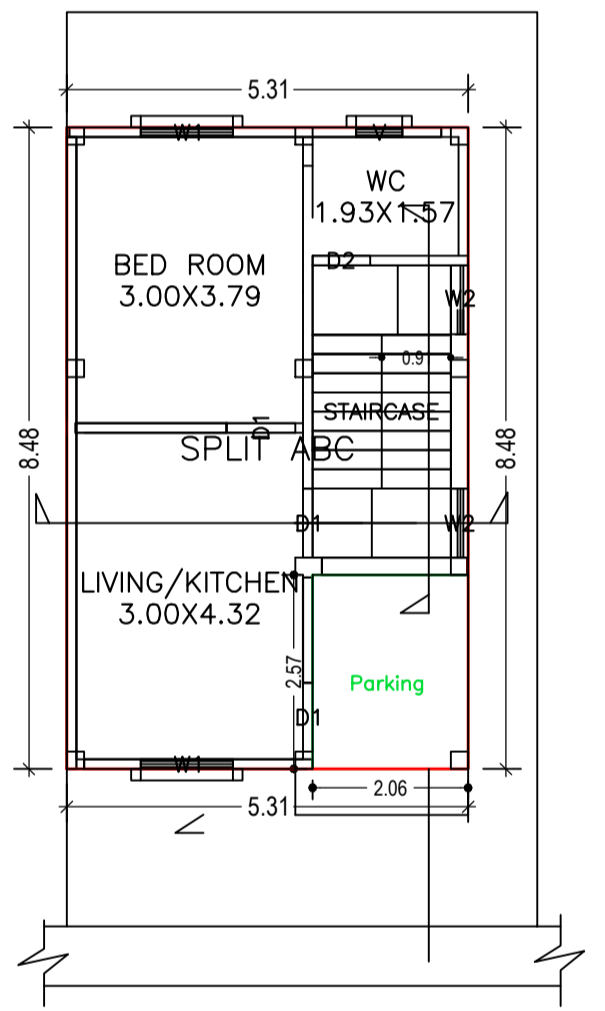
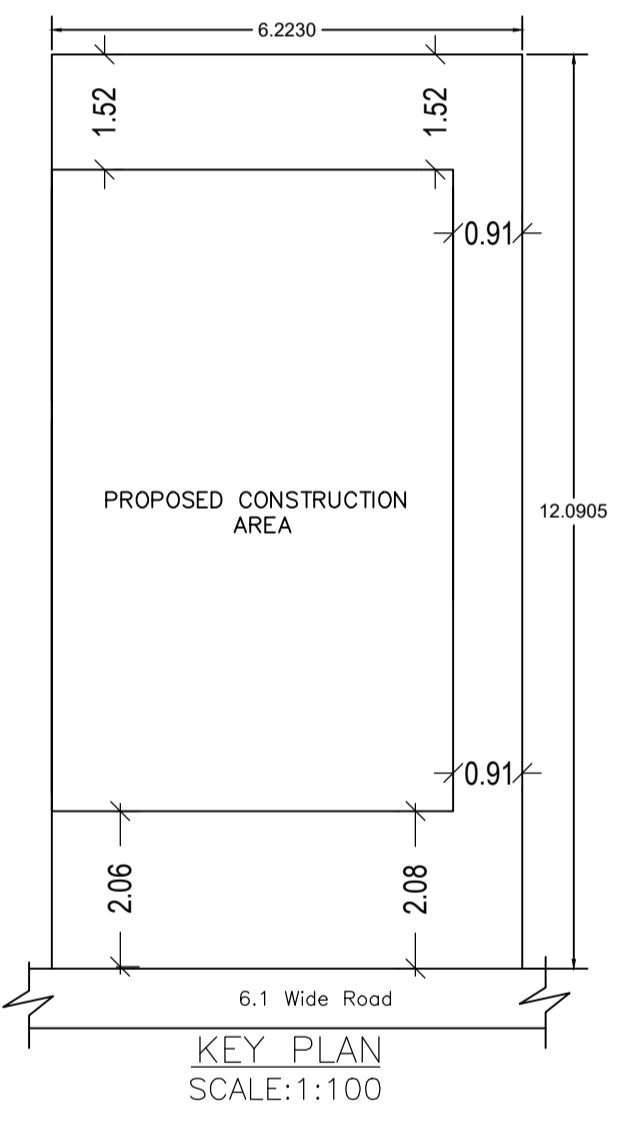
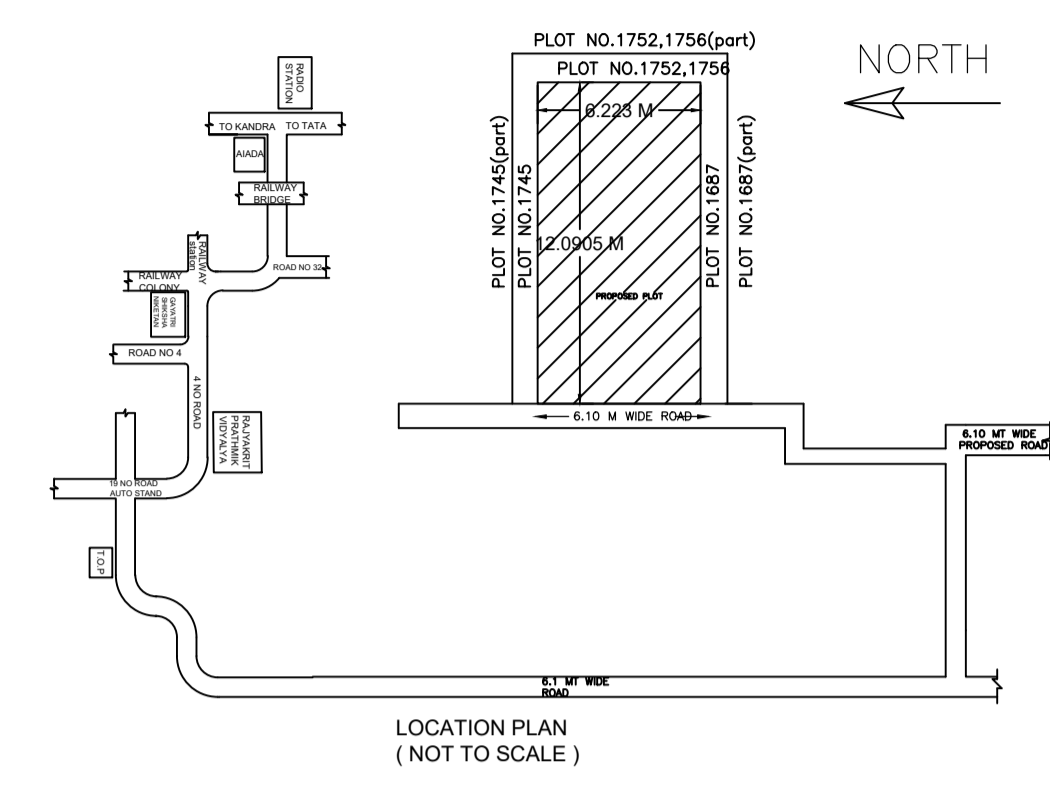
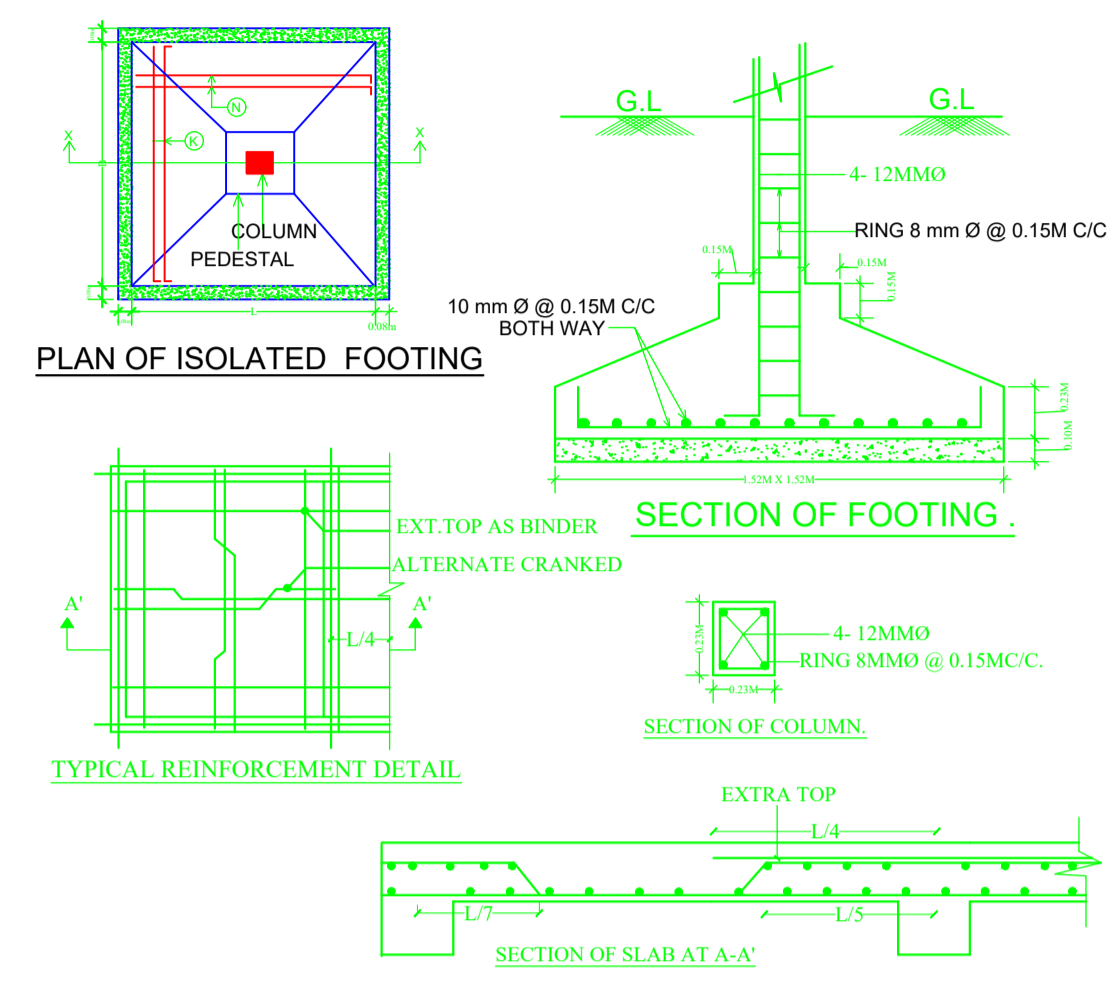
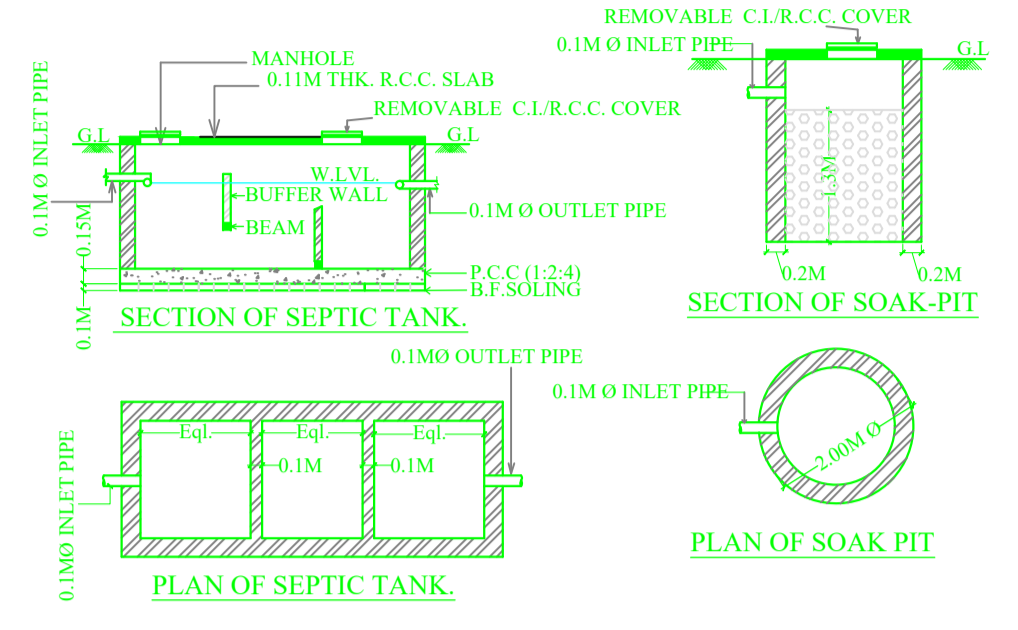
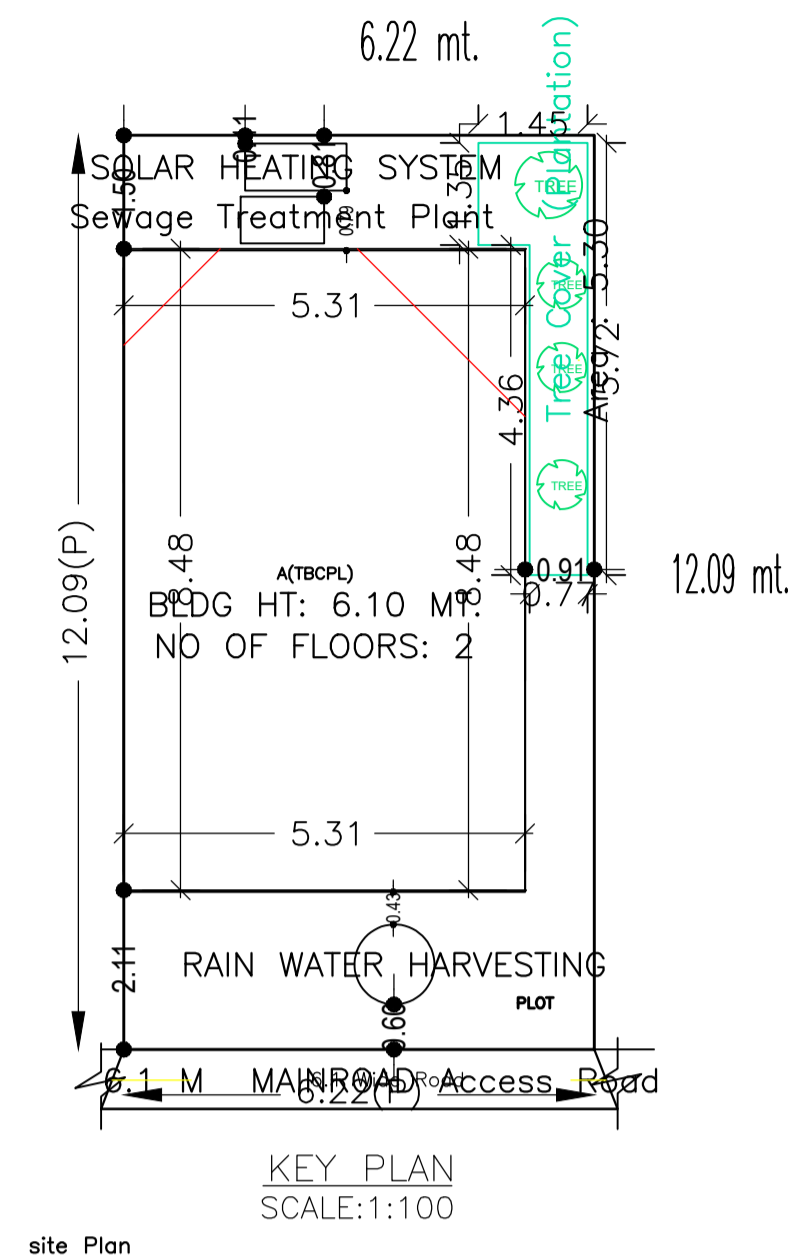

SCHEDULE OF DOOR:

BUILDING NAME	NAME	LENGTH	HEIGHT	NOS
A(TBCPL)	D2	0.76	2.13	02
A(TBCPL)	D1	0.91	2.13	06

SCHEDULE OF WINDOW/VENTILATION:

BUILDING NAME	NAME	LENGTH	HEIGHT	NOS
A(TBCPL)	V	0.61	0.61	02
A(TBCPL)	W2	0.91	1.22	05
A(TBCPL)	W1	1.22	1.22	04

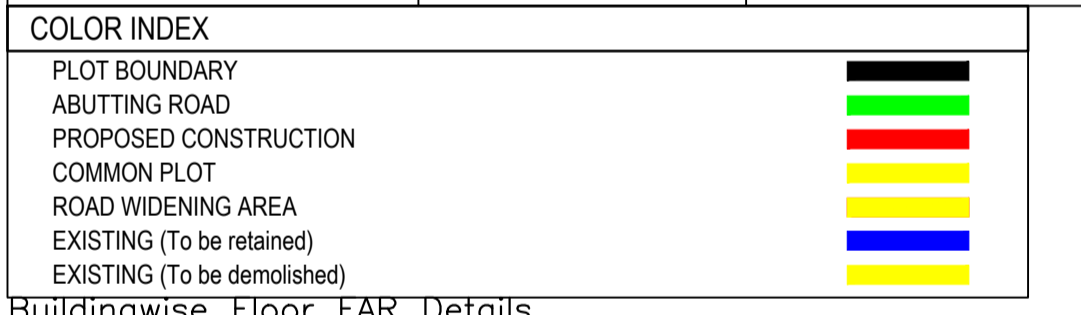

Buildingwise Floor FAR Details

Floor Name	Building Name A(TBCPL)		Total	
	Proposed Built Up Area (Sq.mt.)	Proposed FAR Area (Sq.mt.)	Total Proposed Built Up Area (Sq.mt.)	Total FAR Area (Sq.mt.)
Ground Floor	45.04	45.04	45.04	45.04
First Floor	48.51	48.51	48.51	48.51
Terrace Floor	0.00	0.00	0.00	0.00
Total :	93.55	93.55	93.55	93.55

Building USE/SUBUSE Details

Building Name	Building Use	Building SubUse	Building Structure
A(TBCPL)	Residential	Residential Bldg/Apartment	Non-Highrise

FAR & Tenement Details (Table 4c-1)

Building	No. of Same Bldg	Total Built Up Area (Sq.mt.)	Proposed FAR Area (Sq.mt.)	Total FAR Area (Sq.mt.)	Total Consumed Additional FAR Area (Sq.mt.)	Tnmt (No.)
A(TBCPL)	1	93.55	93.55	93.55	93.55	01
Grand Total :	1	93.55	93.55	93.55	93.55	01

UnitBUA Table for Building :A(TBCPL)

FLOOR	Name	UnitBUA Type	UnitBUA Area	Carpet Area	No. of Rooms	No. of Tenement
GROUND FLOOR PLAN	SPLIT ABC	FLAT	87.71	80.84	3	1
FIRST FLOOR PLAN	SPLIT ABC	FLAT	0.00	0.00	4	0
Total:	-	-	87.71	80.84	7	1

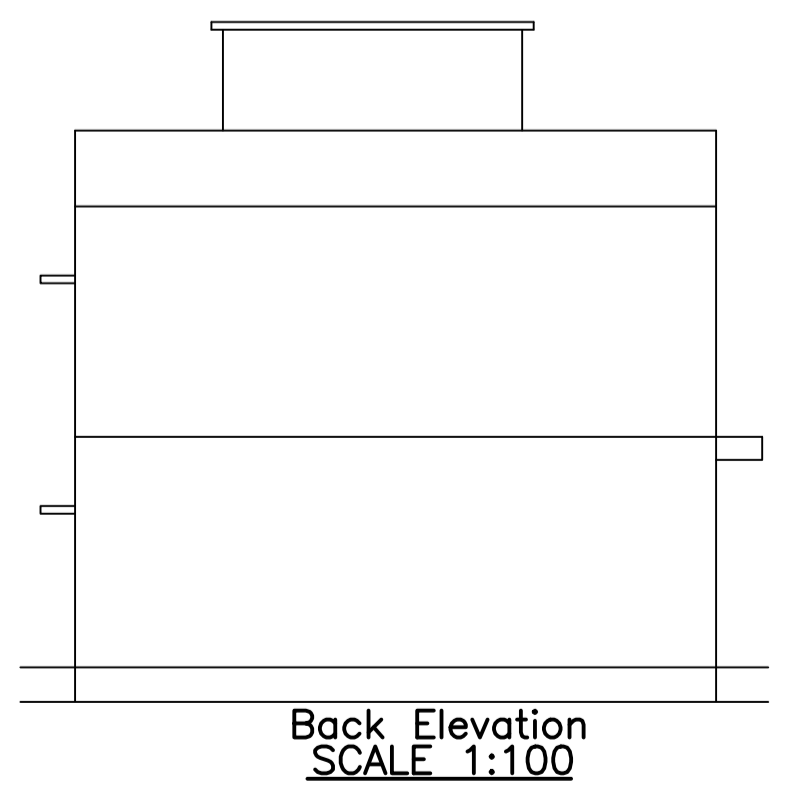
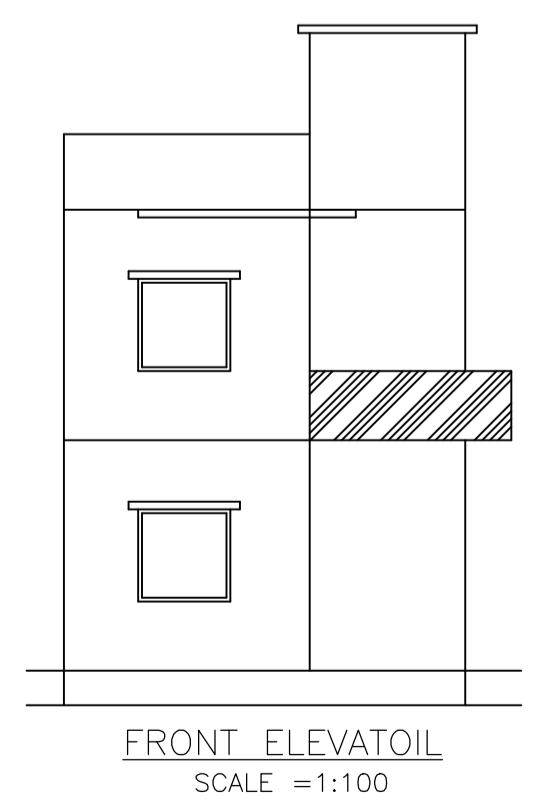
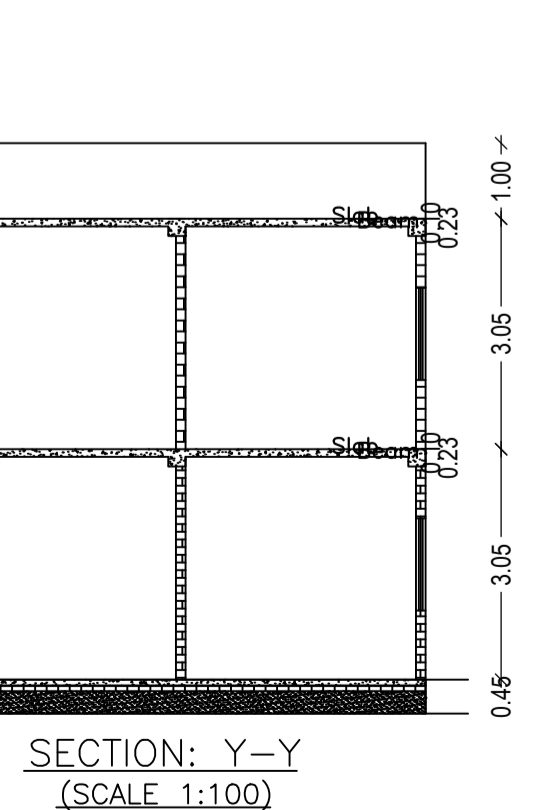
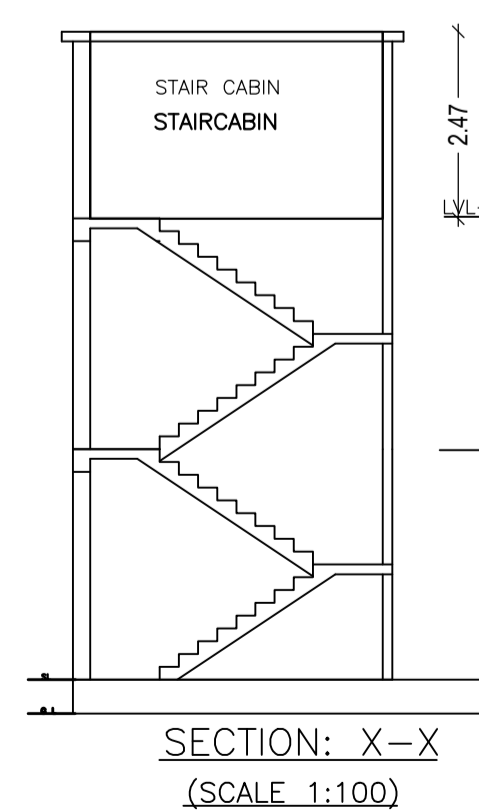

LTP NAME AND SIGNATURE	STRUCTURAL ENG'S NAME AND SIGNATURE	BUILDER NAME AND SIGNATURE	DIGITAL SIGNATURE
MOHAMMAD BELAL NASIR AMC/ENG/0015/2017			