

DETAIL OF FOOTING

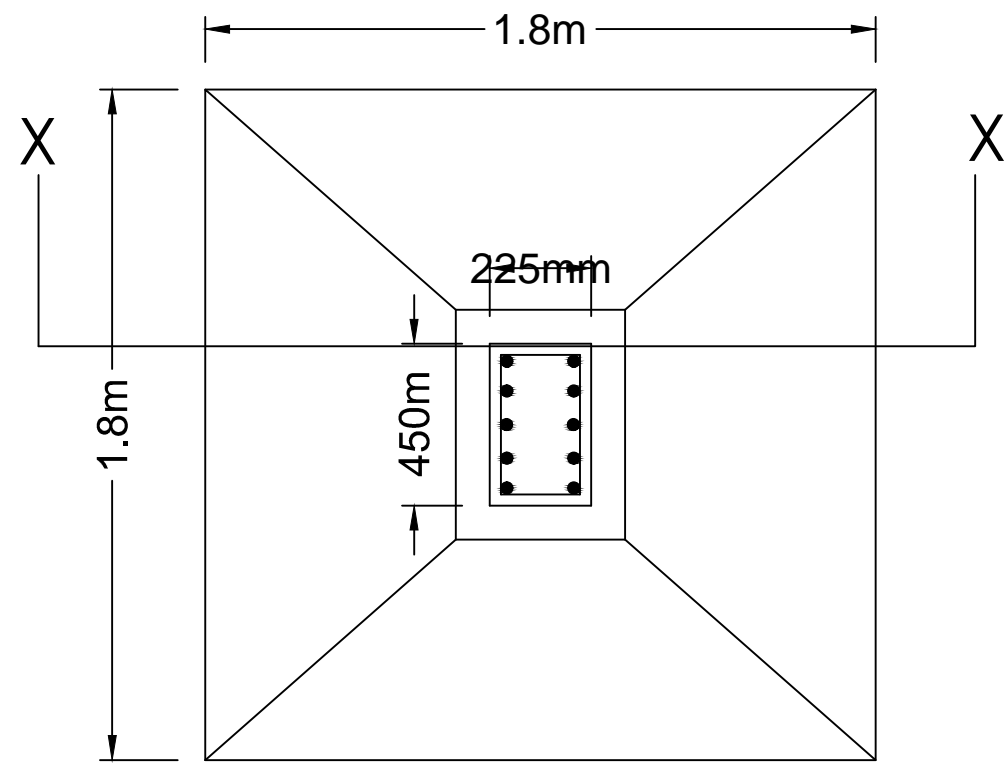

DETAIL OF FOOTING

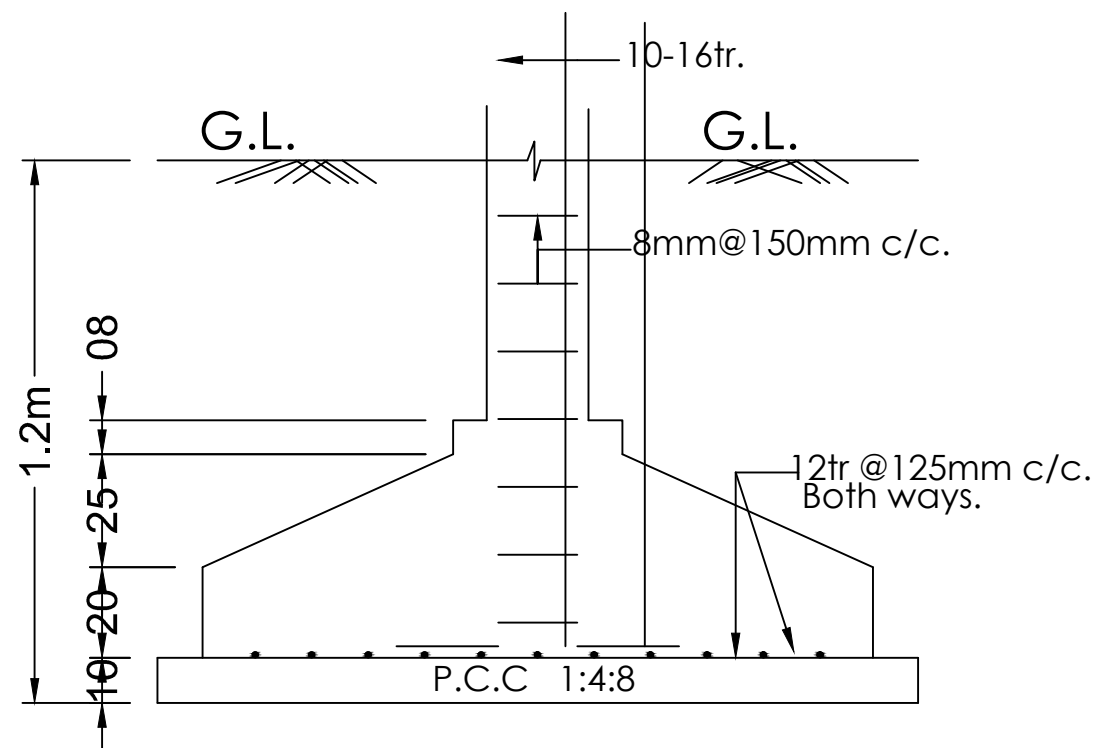

SECTION ON = X-X

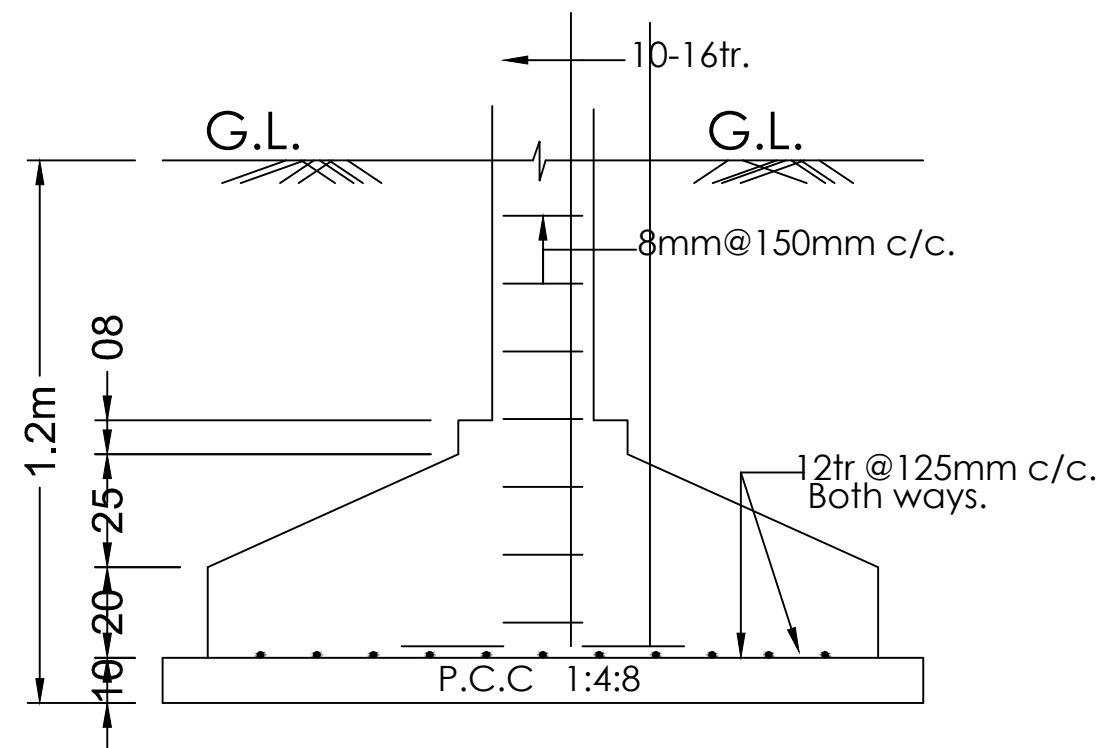

SECTION ON = X-X