

Proposal Basic Information	
Proposal File No.	AMC/BP/0001/W/14/2019
Owner Name	MR. ANAND SHANKAR MISHRA
Khata No	48(O),46(N)
Plot No	459/462 (OLD), 2474 (NEW)
Village Name	ASANGI
Use	Residential
SubUse	Bungalow/ Dwelling / Non Apartment

COLOR INDEX	
PLOT BOUNDARY	Black
ABUTTING ROAD	Red
PROPOSED CONSTRUCTION	Green
COMMON PLOT	Yellow
ROAD WIDENING AREA	Blue
EXISTING (To be retained)	Light Blue
EXISTING (To be demolished)	Orange

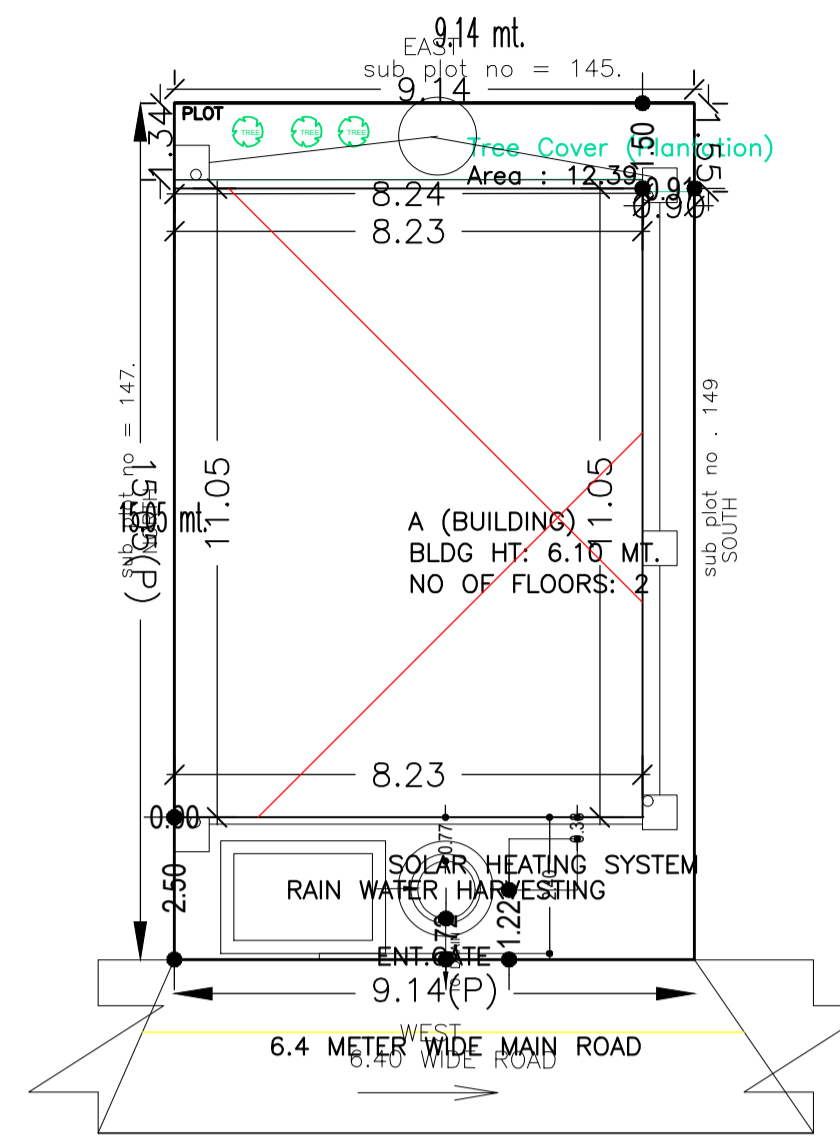

SITE PLAN
SCALE = 1:200

Buildingwise Floor FAR Details

Floor Name	Building Name A (BUILDING)		Total	
	Proposed Built Up Area (Sq.mt.)	Proposed FAR Area (Sq.mt.)	Total Proposed Built Up Area (Sq.mt.)	Total FAR Area (Sq.mt.)
Ground Floor	90.96	49.57	90.96	49.57
First Floor	92.18	92.18	92.18	92.18
Terrace Floor	0.00	0.00	0.00	0.00
Total	183.14	141.75	183.14	141.75

Building USE/SUBUSE Details

Building Name	Building Use	Building SubUse	Building Structure
A (BUILDING)	Residential	Bungalow/ Dwelling / Non Apartment	Non-Highrise

AREA STATEMENT		VERSION NO.: 1.0.37
ADITYAPUR MUNICIPAL CORPORATION		VERSION DATE: 29/04/2019
PROJECT DETAIL:		
Region: JHARKHAND URBAN LOCAL BODIES	Plot Use: Residential	
District: EAST SINGHBHUM	Plot SubUse: Bungalow/ Dwelling / Non Apartment	
Authority: ADITYAPUR MUNICIPAL CORPORATION	PlotNearbyReligiousStructure: NA	
Inward No: AMC/BP/0001/W/14/2019	Plot/SubPlot No: 459/462 (OLD), 2474 (NEW)	
Application Type: General Proposal	North: Plot No. - SUB PLOT NO-147	
Project Type: Building Permission	South: Plot No. - SUB PLOT NO-149	
Nature of Development: New	East: Plot No. - sub plot no-145	
Location of Development Area: Old Area	West: Road Width - 6.4	
AREA DETAILS:		
AREA OF PLOT (Minimum)	(A)	SQ.MT. 137.64
NET AREA OF PLOT(Gross Plot Area - Deduction from Gross Plot area)	(A-Deductions)	137.64
Deduction for Balance Plot Area(from Gross Plot Area)		
Common Plot		12.39
Total		12.39
BALANCE AREA OF PLOT(Net Plot Area - Recreational/Amenity space)	(A-Deductions)	125.25
PLOT AREA FOR COVERAGE(Net Plot Area)	(A-Deductions)	137.64
Plot Area for FAR (Net Plot Area + RoadWidening Area)	(A-Deductions)	137.64
COVERAGE CHECK		
Permissible Coverage area (70.00 %)		96.35
Proposed Coverage Area (66.09 %)		90.96
Total Prop. Coverage Area (66.09 %)		90.96
Balance coverage area (3.92 %)		5.39
FAR CHECK		
Perm. FAR Area (2.50)		344.10
Total Perm. FAR area		344.10
Residential FAR		141.75
Proposed FAR Area		141.75
Total Proposed FAR Area		141.75
Consumed FAR (Factor)		1.03
Balance FAR Area		202.35
BUILT UP AREA CHECK		
Total Proposed BuiltUp Area		183.14
ARCHITECT (Regd)	S M SHAHREYAR	
ENGINEER (Regd)		
SUPERVISOR (Regd)		
OWNER (Regd)	MR. ANAND SHANKAR MISHRA	
DEVELOPMENT AUTHORITY		LOCAL BODY

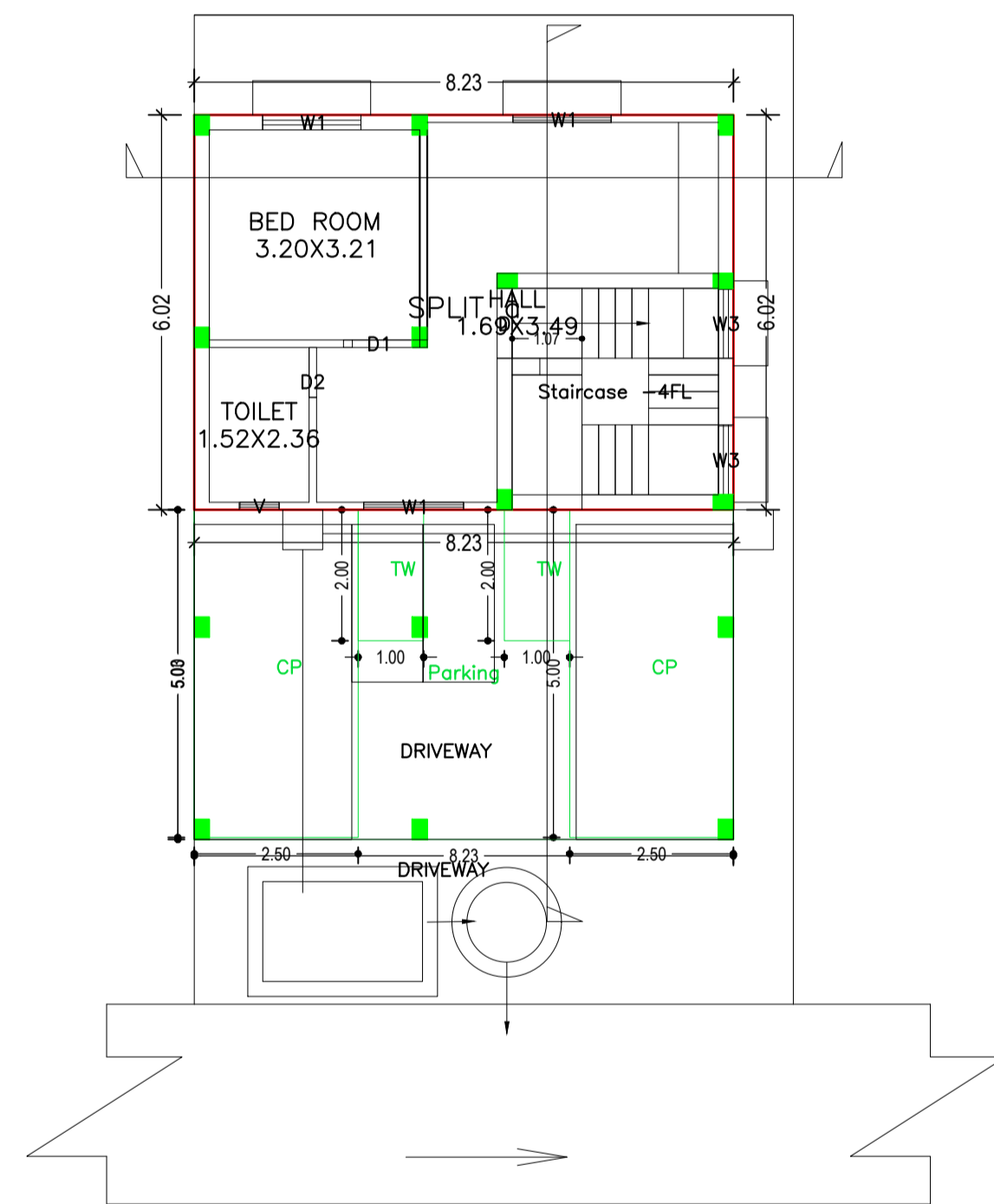

GROUND FLOOR PLAN
(Proposed)
SCALE 1:100

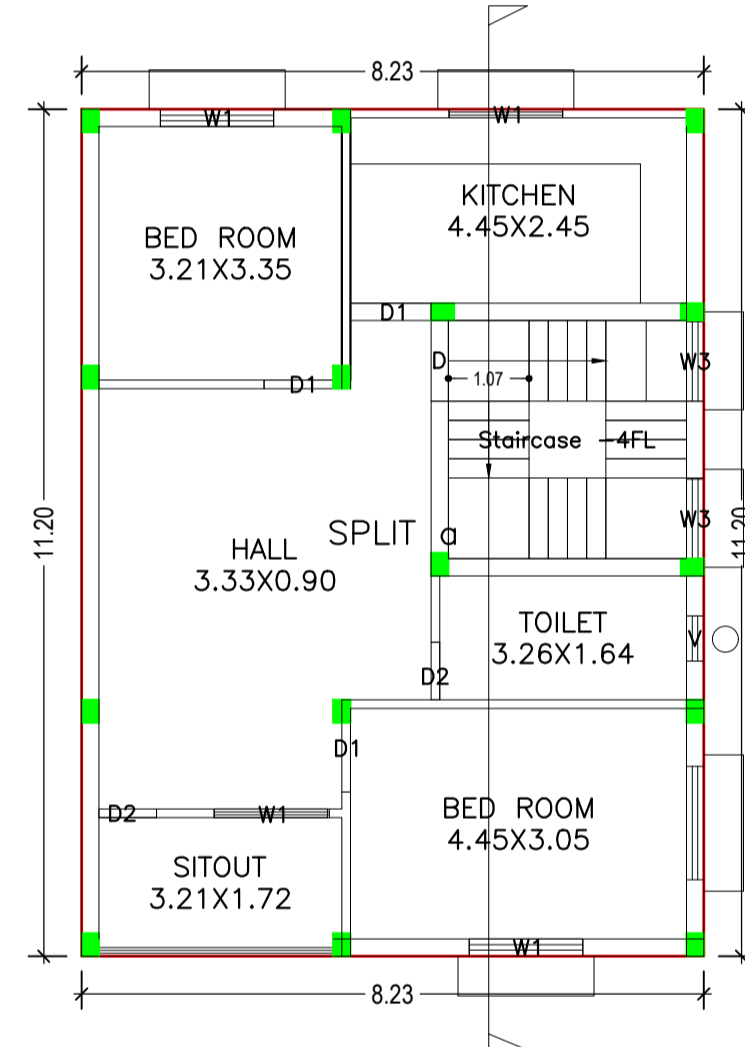

FIRST FLOOR PLAN
(Proposed)
SCALE 1:100

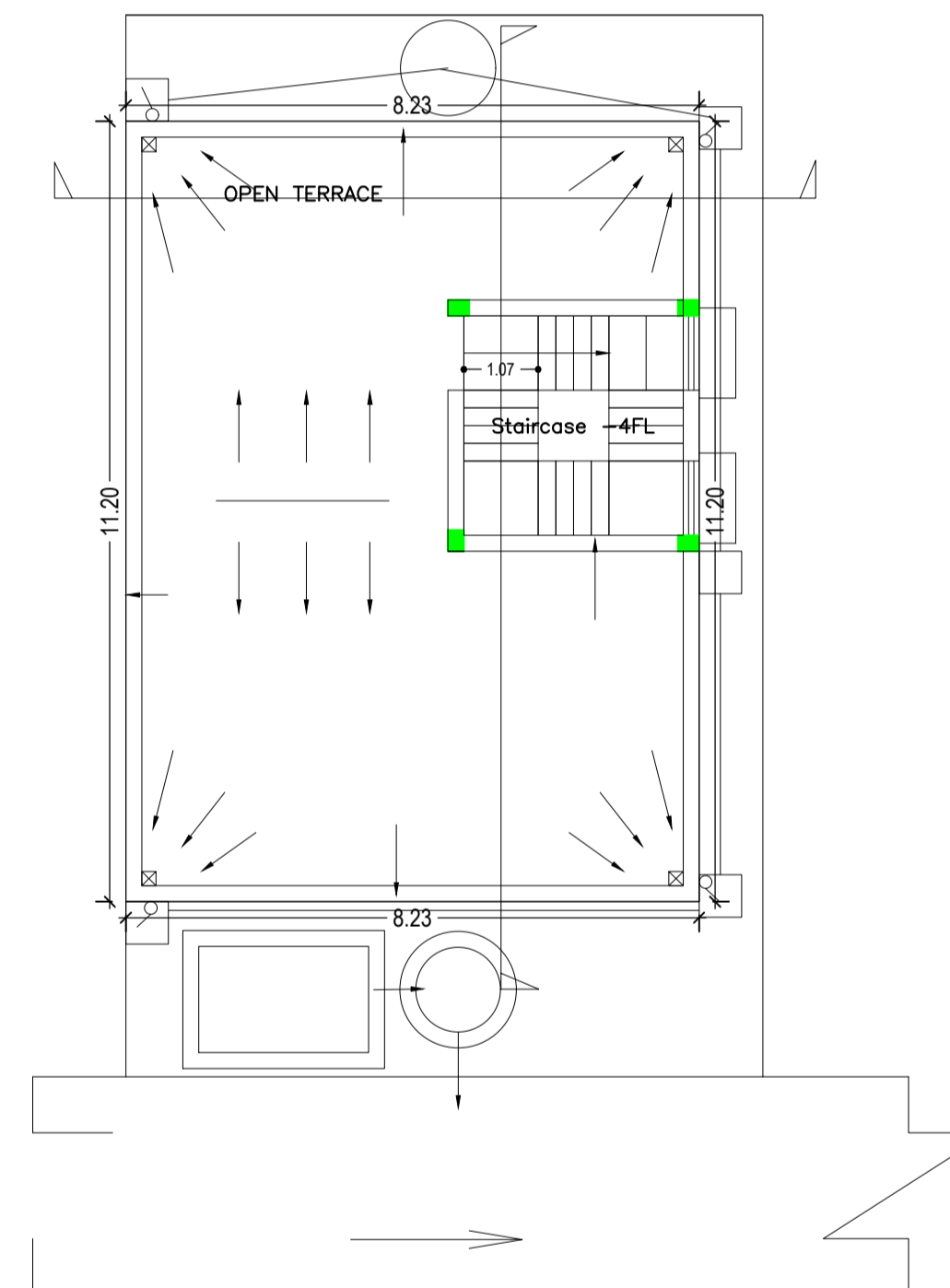

TERRACE FLOOR PLAN
(SCALE 1:100)

FAR & Tenement Details (Table 4c-1)

Building	No. of Same Bldg	Total Built Up Area (Sq.mt.)	Deductions (Area in Sq.mt.)		Proposed FAR Area (Sq.mt.)	Total FAR Area (Sq.mt.)	Total Consumed Additional FAR Area (Sq.mt.)	Trmt (No.)
			Parking	Resi.				
A (BUILDING)	1	183.14	41.39		141.75	141.75	141.75	01
Grand Total :	1	183.14	41.39		141.75	141.75	141.75	01

LTP NAME AND SIGNATURE	STRUCTURAL ENG'S NAME AND SIGNATURE	BUILDER NAME AND SIGNATURE	DIGITAL SIGNATURE
S M SHAHREYAR AMC/SUP/0010/2018			

Proposal Basic Information

Proposal File No.	AMC/BP/0001/W14/2019
Owner Name	MR. ANAND SHANKAR MISHRA
Khata No	48(O),46(N)
Plot No	459/462 (OLD), 2474 (NEW)
Village Name	ASANGI
Use	Residential
SubUse	Bungalow/ Dwelling / Non Apartment

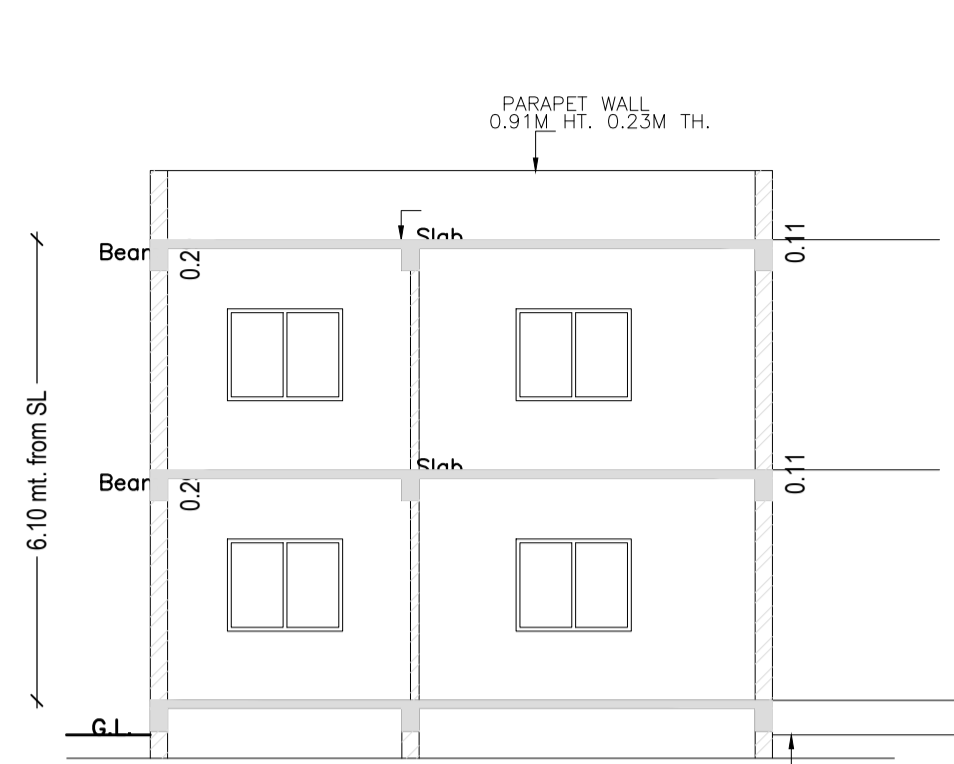

SECTION OF X-X
SCALE = 1:100

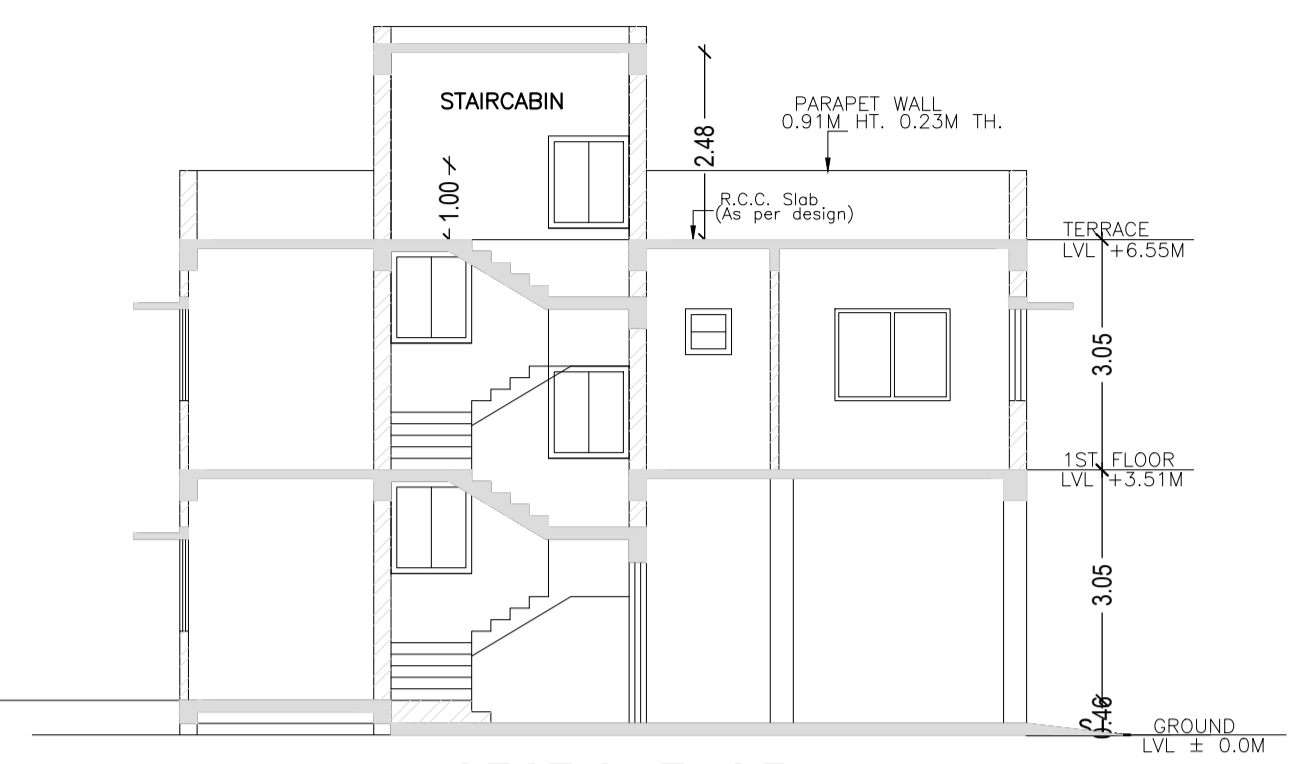

SECTION OF Y-Y
SCALE = 1:100

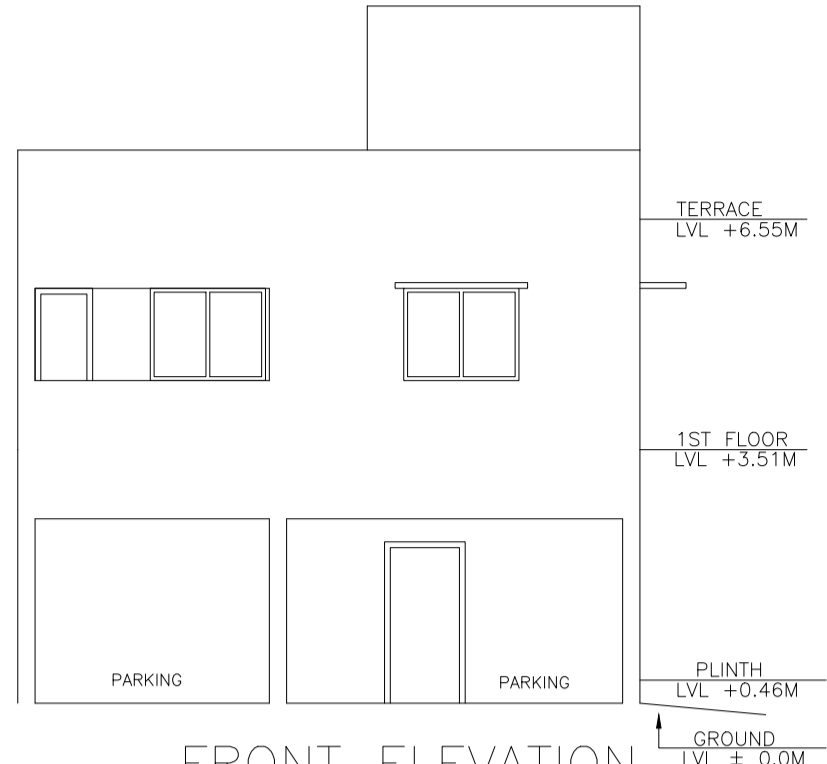

FRONT ELEVATION
SCALE = 1:100

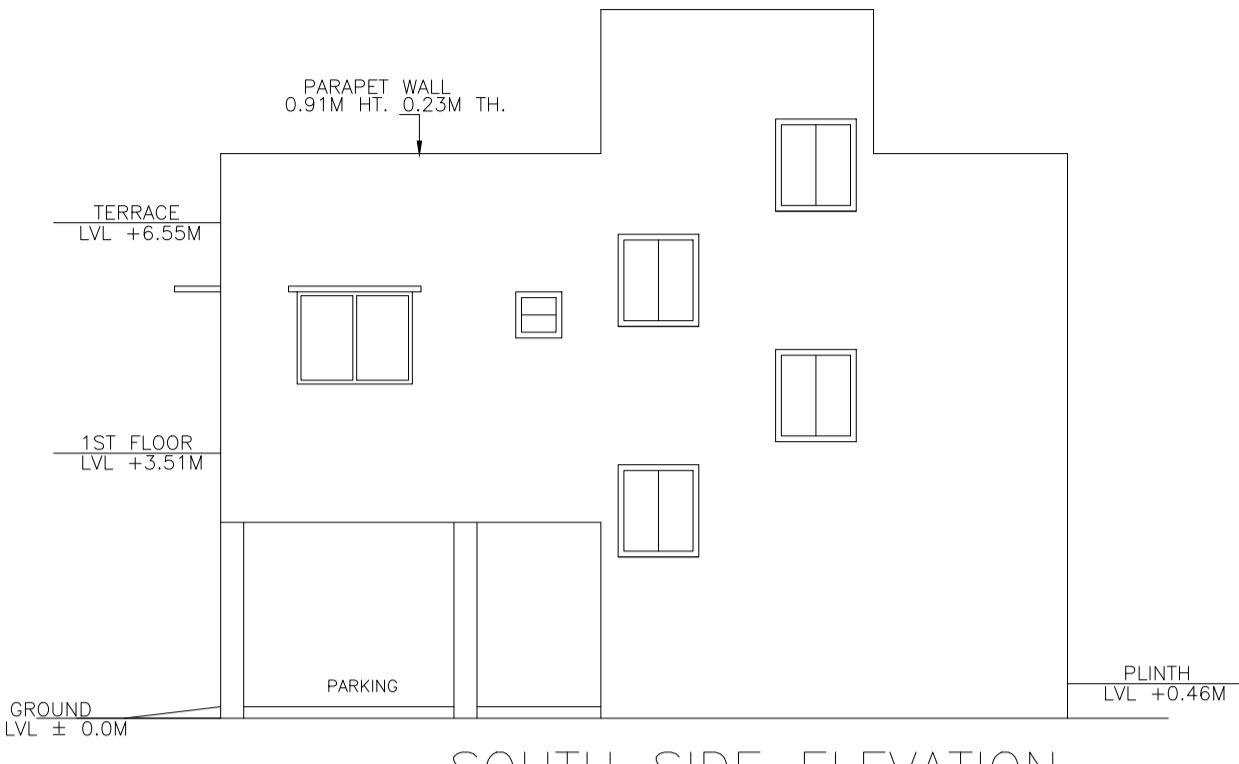

SOUTH SIDE ELEVATION
SCALE = 1:100

Building :A (BUILDING)

Floor Name	Total Built Up Area (Sq.mt.)	Deductions (Area in Sq.mt.)		Proposed FAR Area (Sq.mt.)	Total FAR Area (Sq.mt.)	Total Consumed Additional FAR Area (Sq.mt.)	Trmt (No.)
		Parking	Resi.				
Ground Floor	90.96	41.39	49.57	49.57	49.57	01	
First Floor	92.18	0.00	92.18	92.18	92.18	00	
Terrace Floor	0.00	0.00	0.00	0.00	0.00	00	
Total :	183.14	41.39	141.75	141.75	141.75	01	
Total Number of Same Buildings :	1						
Total :	183.14	41.39	141.75	141.75	141.75	01	

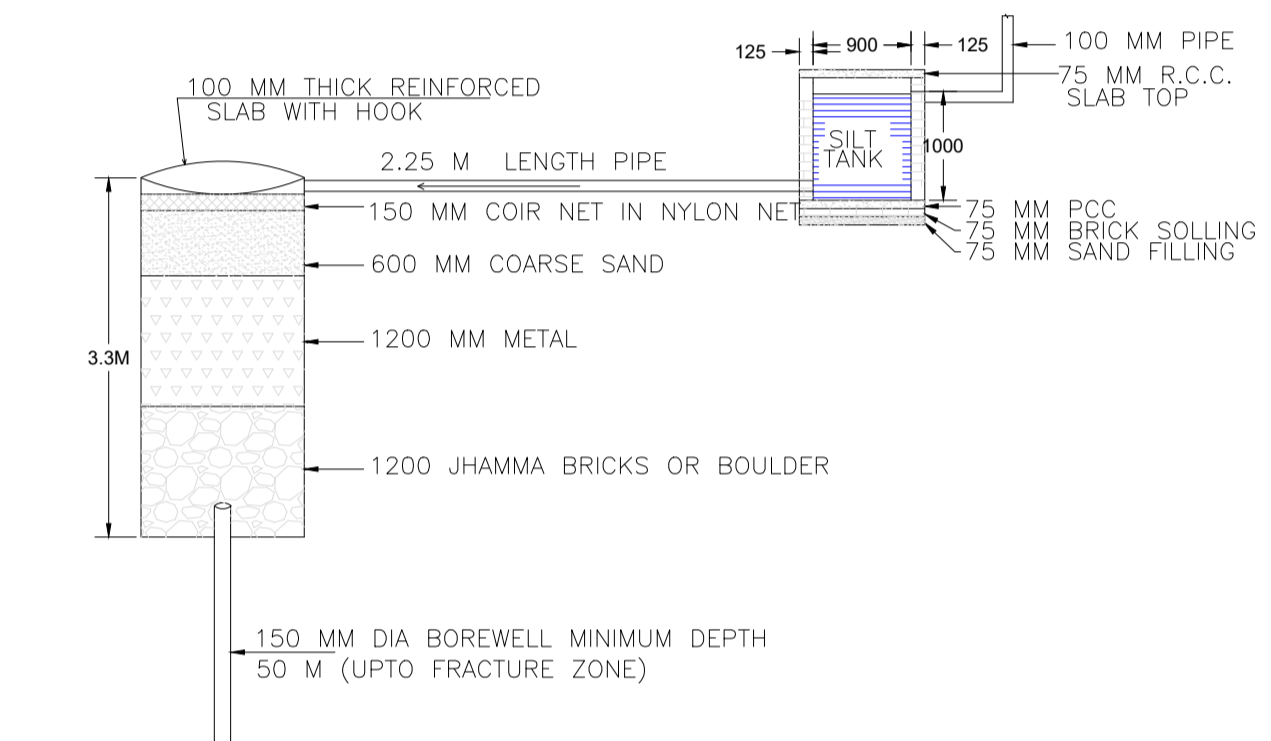

DETAILS OF GROUND WATER RECHARGING PIT WITH SILT TANK RAIN WATER HARVESTING DETAIL

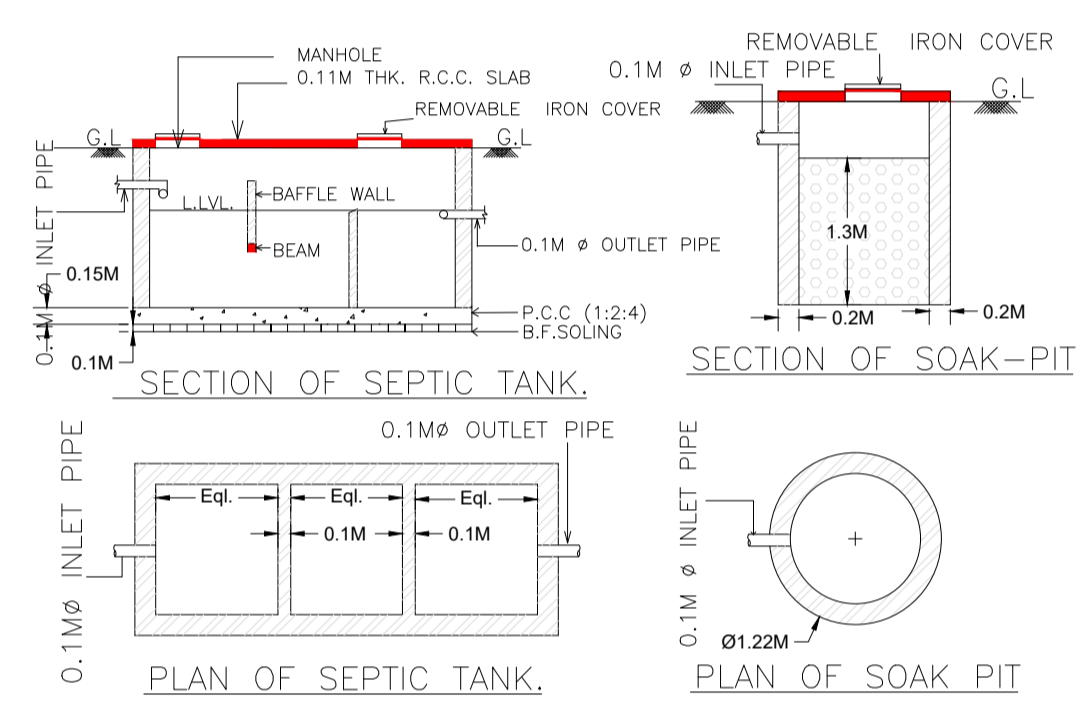

SECTION OF SEPTIC TANK

SECTION OF SOAK-PIT

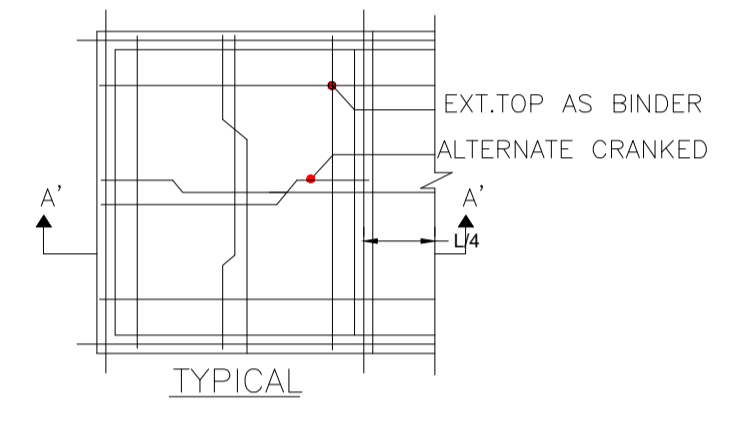
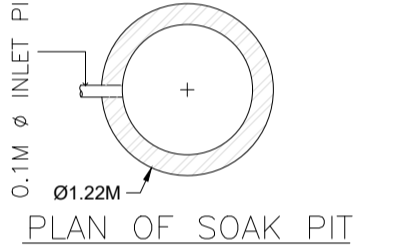
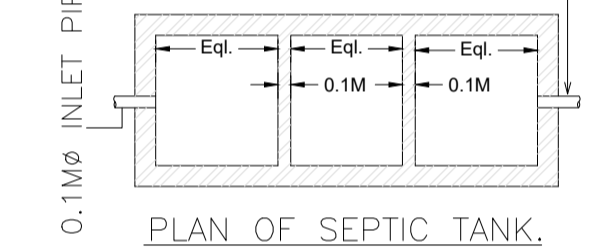

TYPICAL

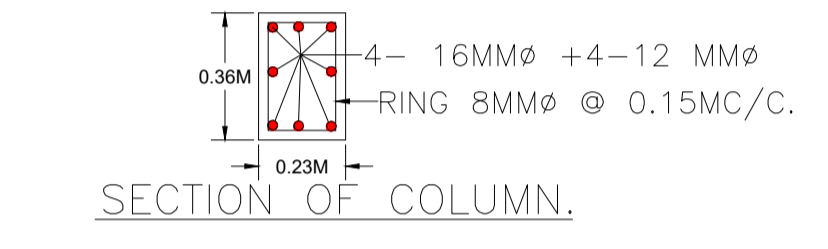

SECTION OF COLUMN

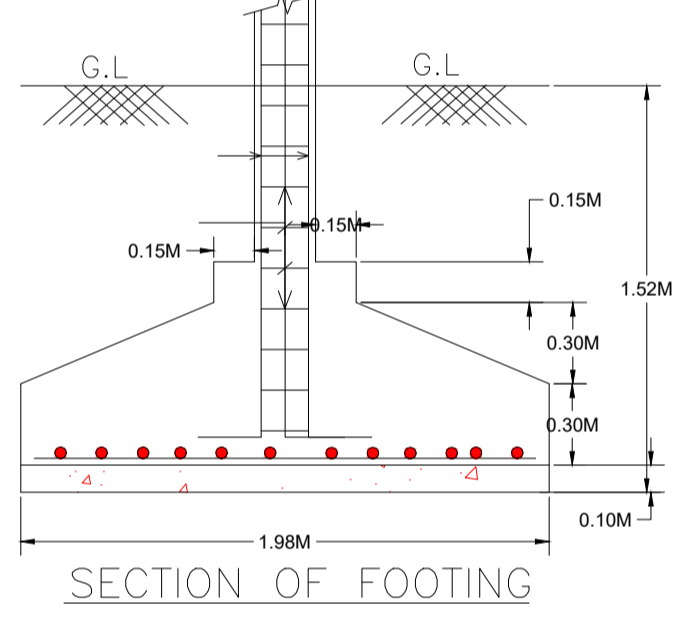

SECTION OF FOOTING

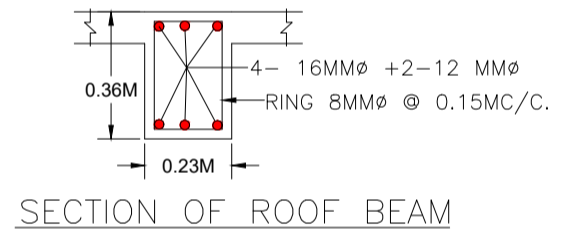

SECTION OF ROOF BEAM

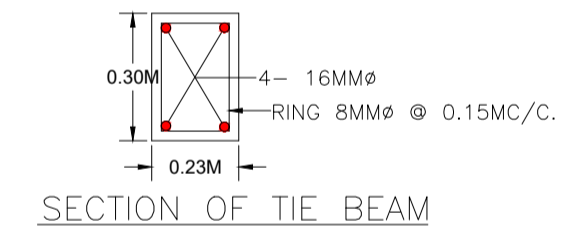

SECTION OF TIE BEAM

SCHEDULE OF DOOR:

BUILDING NAME	NAME	LENGTH	HEIGHT	NOS
A (BUILDING)	D2	0.76	2.10	03
A (BUILDING)	D1	1.03	2.10	01
A (BUILDING)	D1	1.05	2.10	01
A (BUILDING)	D1	1.07	2.10	01
A (BUILDING)	D	1.07	2.10	02
A (BUILDING)	D1	1.10	2.10	01

SCHEDULE OF WINDOW/VENTILATION:

BUILDING NAME	NAME	LENGTH	HEIGHT	NOS
A (BUILDING)	V	0.60	1.20	02
A (BUILDING)	W3	1.05	1.20	04
A (BUILDING)	W1	1.50	1.20	06
A (BUILDING)	W1	1.52	1.20	01

UnitBUA Table for Building :A (BUILDING)

FLOOR	Name	UnitBUA Type	UnitBUA Area	Carpet Area	No. of Rooms	No. of Tenement
GROUND FLOOR PLAN	SPLIT a	FLAT	105.08	104.31	3	1
FIRST FLOOR PLAN	SPLIT a	FLAT	0.00	0.00	6	0
Total:	-	-	105.08	104.31	9	1

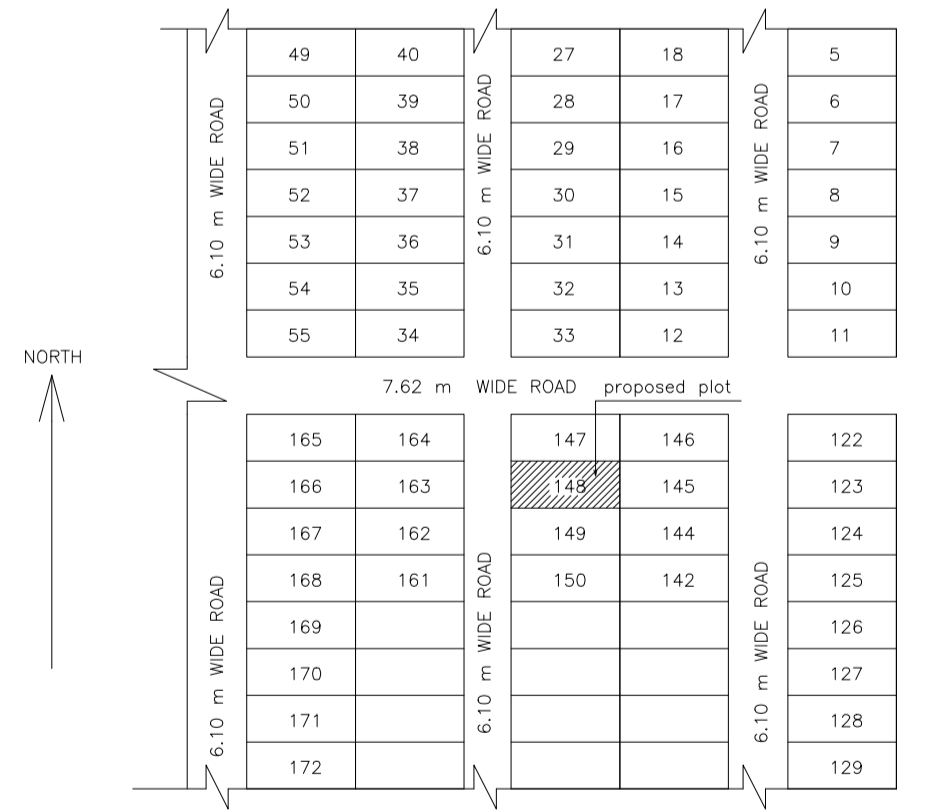

LOCATION PLAN
SCALE = N.T.S.

LTP NAME AND SIGNATURE	STRUCTURAL ENG'S NAME AND SIGNATURE	BUILDER NAME AND SIGNATURE	DIGITAL SIGNATURE
S M SHAHREYAR AMC/SUP/0010/2018			