

Proposal Basic Information

Proposal File No.	AMC/BP/0013/W22/2019
Owner Name	MRS. NEETA SINGH
Khata No	113 (N), 234(O)
Plot No	2492 (N), 453 (O)
Village Name	ASANGI
Use	Residential
SubUse	Bungalow/ Dwelling / Non Apartment

AREA STATEMENT

ADITYAPUR MUNICIPAL CORPORATION	VERSION NO.: 1.0.35	VERSION DATE: 13/03/2019
Region: JHARKHAND URBAN LOCAL BODIES	Plot Use: Residential	
District: EAST SINGBHUM	Plot SubUse: Bungalow/ Dwelling / Non Apartment	
Authority: ADITYAPUR MUNICIPAL CORPORATION	PlotNearby/ReligiousStructure: NA	
Inward_No: AMC/BP/0013/W22/2019	Plot/SubPlot No: 2492 (N), 453 (O)	
Application Type: General Proposal	North: Plot No. - 2492	
Project Type: Building Permission	South: Plot No. - 2492	
Nature of Development: New	East: Plot No. - 2492	
Location of Development Area: Old Area	West: Road Width - 6.1	
AREA DETAILS		SQ.MT.
AREA OF PLOT (Minimum)	(A)	74.37
NET AREA OF PLOT (Gross Plot Area - Deduction from Gross Plot area)	(A-Deductions)	74.37
Deduction for Balance Plot Area (from Gross Plot Area)		
Common Plot		5.61
Total		5.61
BALANCE AREA OF PLOT (Net Plot Area - Recreational/Amenity space)	(A-Deductions)	68.76
PLOT AREA FOR COVERAGE (Net Plot Area)	(A-Deductions)	74.37
Plot Area for FAR (Net Plot Area + Road Widening Area)	(A-Deductions)	74.37
COVERAGE CHECK		
Permissible Coverage area (70.00 %)		52.06
Proposed Coverage Area (61.28 %)		45.57
Total Prop. Coverage Area (61.28 %)		45.57
Balance coverage area (8.73 %)		6.49
FAR CHECK		
Perm. FAR Area (2.50)		185.93
Total Perm. FAR area		185.93
Residential FAR		96.11
Proposed FAR Area		96.11
Total Proposed FAR Area		96.11
Consumed FAR (Factor)		1.29
Balance FAR Area		89.82
BUILT UP AREA CHECK		
Total Proposed BuiltUp Area		96.11
ARCHITECT (Regd)	MOHAMMAD BELAL NASIR	
ENGINEER (Regd)		
SUPERVISOR (Regd)		
OWNER (Regd)	MRS. NEETA SINGH	
DEVELOPMENT AUTHORITY		LOCAL BODY

COLOR INDEX

PLOT BOUNDARY	Black
ABUTTING ROAD	Green
PROPOSED CONSTRUCTION	Red
COMMON PLOT	Yellow
ROAD WIDENING AREA	Blue
EXISTING (To be retained)	White
EXISTING (To be demolished)	Grey

UnitBUA Table for Building :A(NEETA SINGH)

FLOOR	Name	UnitBUA Type	UnitBUA Area	Carpet Area	No. of Rooms	No. of Tenement
GROUND FLOOR PLAN	SPLIT ABC	FLAT	89.98	87.40	3	1
FIRST FLOOR PLAN	SPLIT ABC	FLAT	0.00	0.00	6	0
Total:			89.98	87.40	9	1

SCHEDULE OF DOOR:

BUILDING NAME	NAME	LENGTH	HEIGHT	NOS
A(NEETA SINGH)	D2	0.76	2.13	06
A(NEETA SINGH)	D1	0.99	2.13	02

SCHEDULE OF WINDOW/VENTILATION:

BUILDING NAME	NAME	LENGTH	HEIGHT	NOS
A(NEETA SINGH)	V	0.76	0.61	02
A(NEETA SINGH)	W2	0.91	1.22	04
A(NEETA SINGH)	W1	1.22	1.22	04

Building :A(NEETA SINGH)

Floor Name	Total Built Up Area (Sq.mt.)	Proposed FAR Area (Sq.mt.) Resi.	Total FAR Area (Sq.mt.)	Total Consumed Additional FAR Area (Sq.mt.)	Trmt (No.)
Ground Floor	45.57	45.57	45.57	45.57	01
First Floor	50.54	50.54	50.54	50.54	00
Terrace Floor	0.00	0.00	0.00	0.00	00
Total:	96.11	96.11	96.11	96.11	01
Total Number of Same Buildings :	1				
Total :	96.11	96.11	96.11	96.11	01

Buildingwise Floor FAR Details

Floor Name	Building Name A(NEETA SINGH)		Total	
	Proposed Built Up Area (Sq.mt.)	Proposed FAR Area (Sq.mt.)	Total Proposed Built Up Area (Sq.mt.)	Total FAR Area (Sq.mt.)
Ground Floor	45.57	45.57	45.57	45.57
First Floor	50.54	50.54	50.54	50.54
Terrace Floor	0.00	0.00	0.00	0.00
Total:	96.11	96.11	96.11	96.11

Building USE/SUBUSE Details

Building Name	Building Use	Building SubUse	Building Structure
A(NEETA SINGH)	Residential	Residential Bldg/Apartment	Non-Highrise

FAR & Tenement Details (Table 4c-1)

Building	No. of Same Bldg	Total Built Up Area (Sq.mt.)	Proposed FAR Area (Sq.mt.) Resi.	Total FAR Area (Sq.mt.)	Total Consumed Additional FAR Area (Sq.mt.)	Trmt (No.)
A(NEETA SINGH)	1	96.11	96.11	96.11	96.11	01
Grand Total :	1	96.11	96.11	96.11	96.11	01

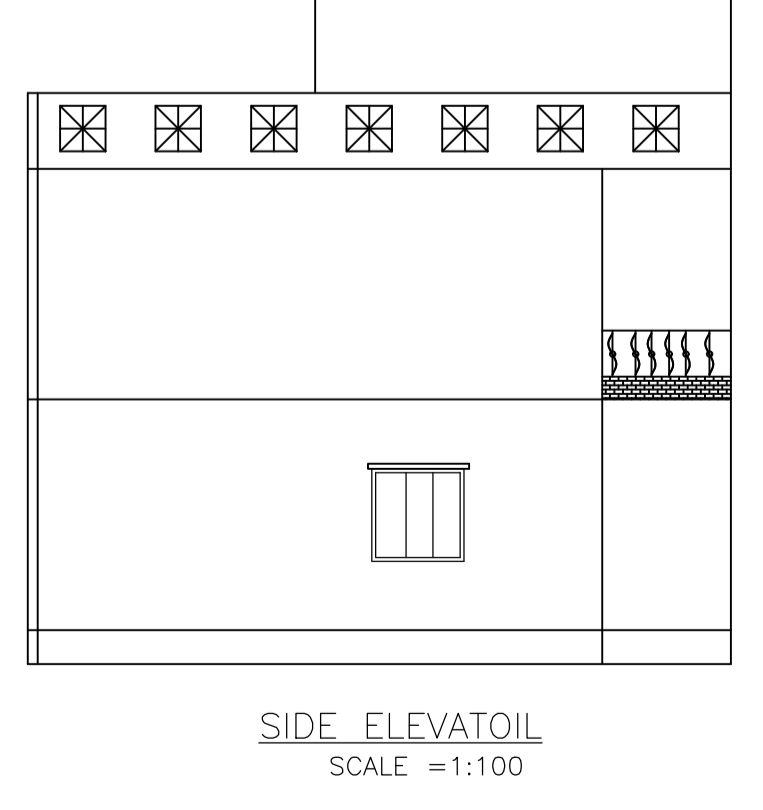
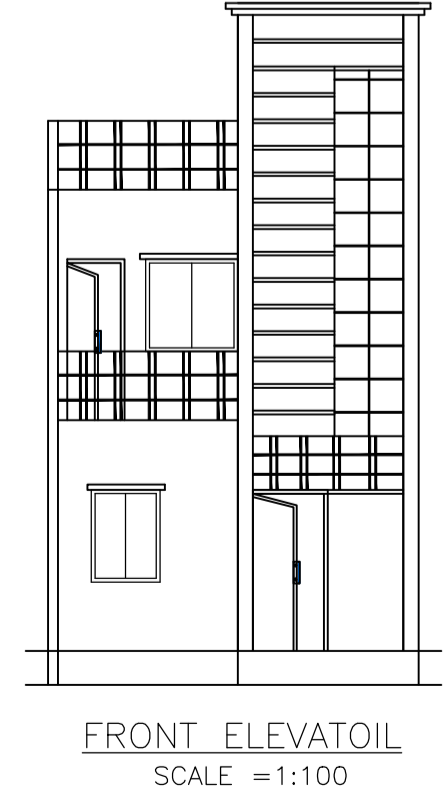
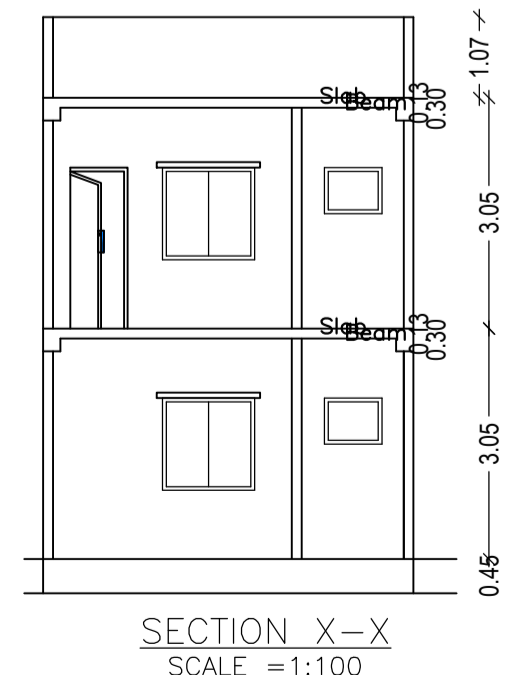
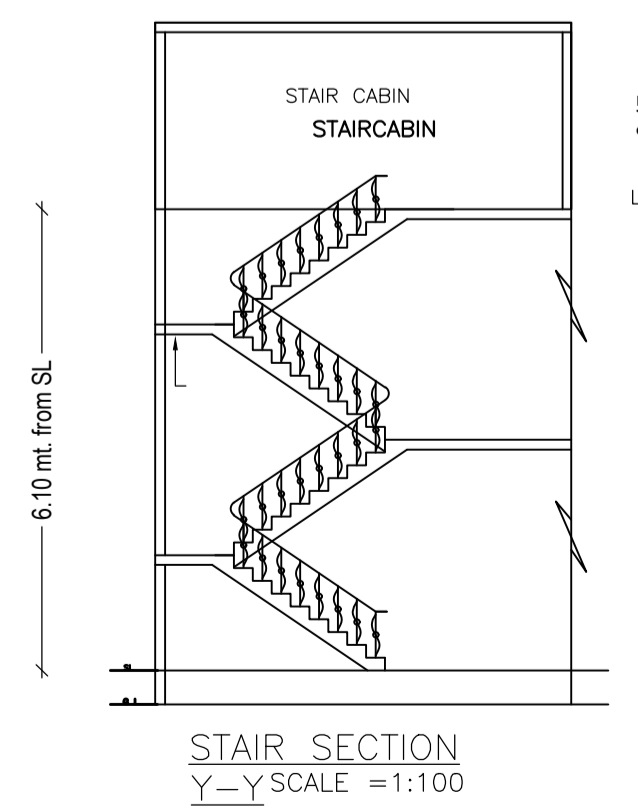
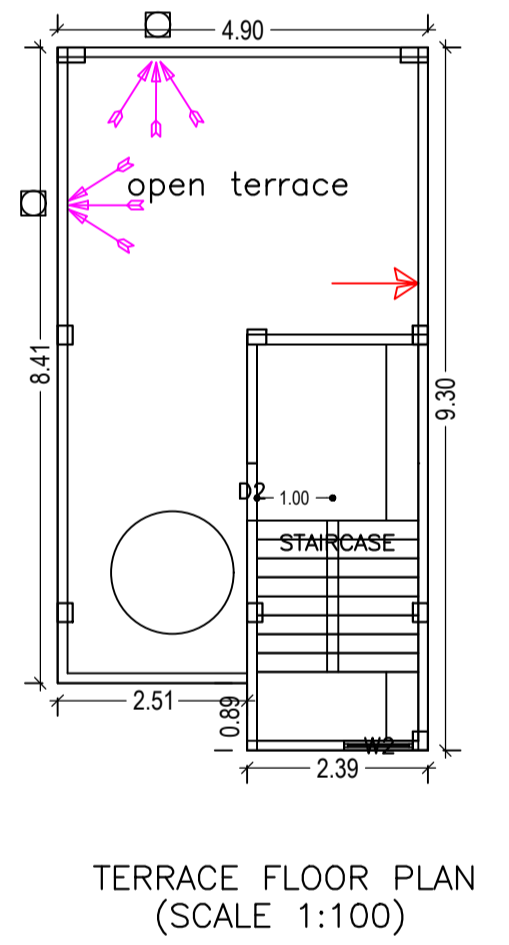
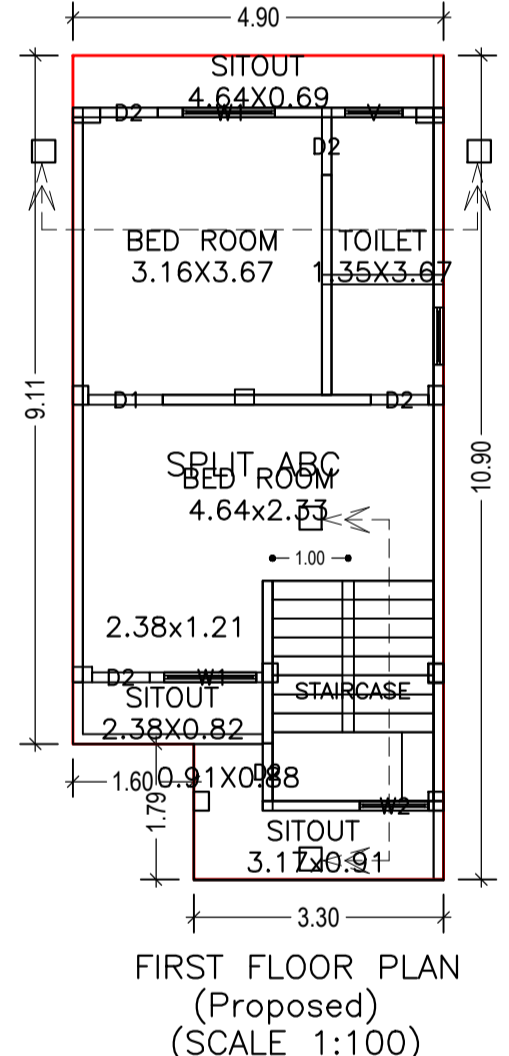
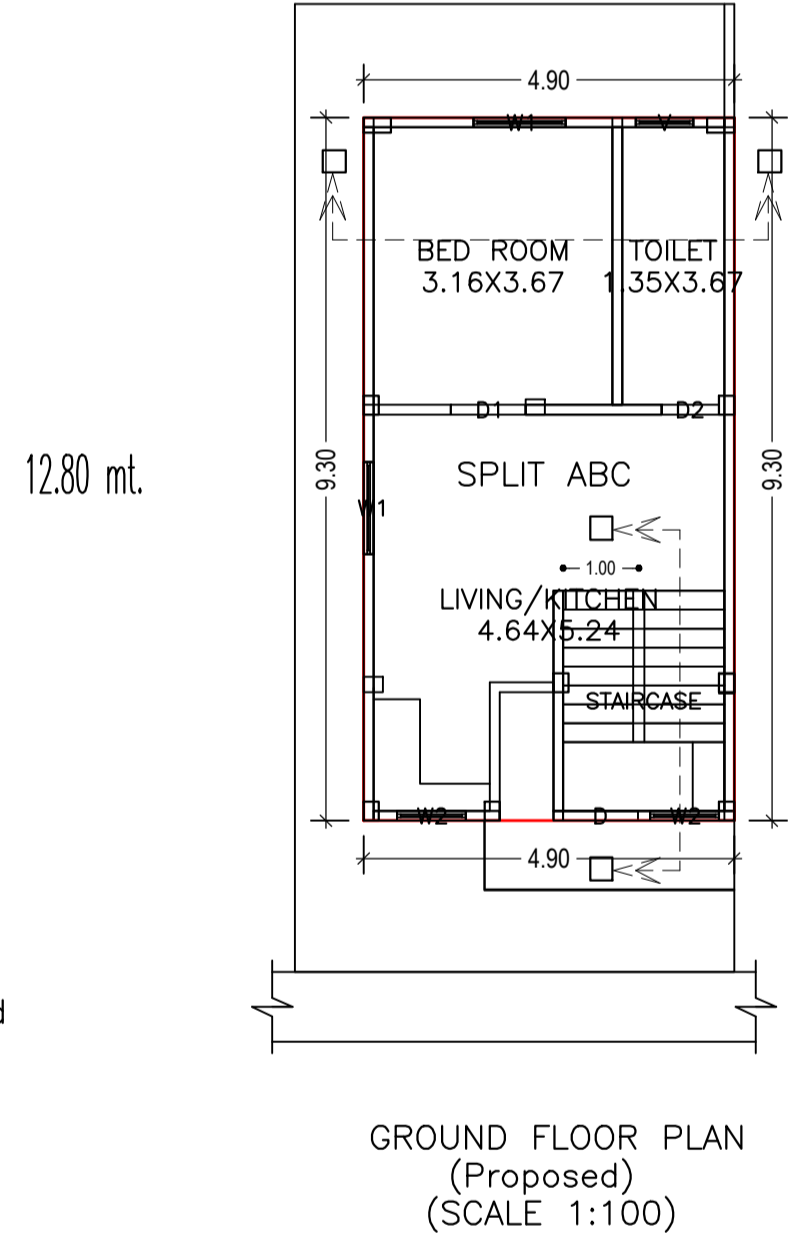
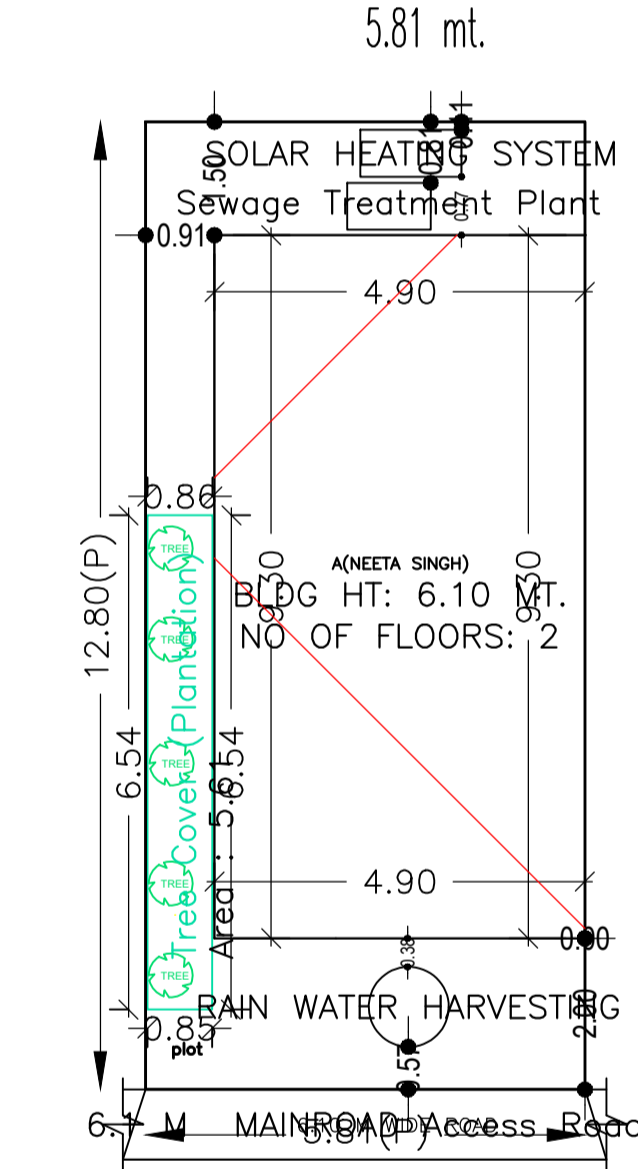

LTP NAME AND SIGNATURE

MOHAMMAD BELAL NASIR AMC/ENG/0015/2017	STRUCTURAL ENG'S NAME AND SIGNATURE	BUILDER NAME AND SIGNATURE	DIGITAL SIGNATURE
---	-------------------------------------	----------------------------	-------------------