

Proposal Basic Information

Proposal File No.	AMC/BP/0048/W32/2019
Owner Name	Technoculture Building Centre Pvt. Ltd.
Khata No	19 (OLD), 61(NEW)
Plot No	587(OLD) & 1688, 1753, 1754, 1755 (NEW)
Village Name	KULUPTANGA
Use	Residential
SubUse	Bungalow/ Dwelling / Non Apartment

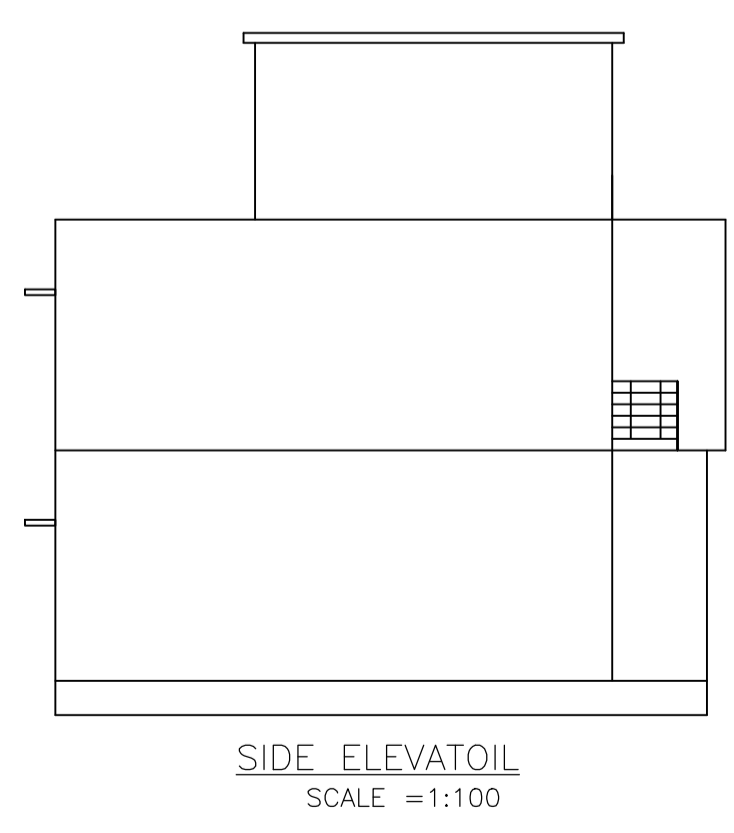
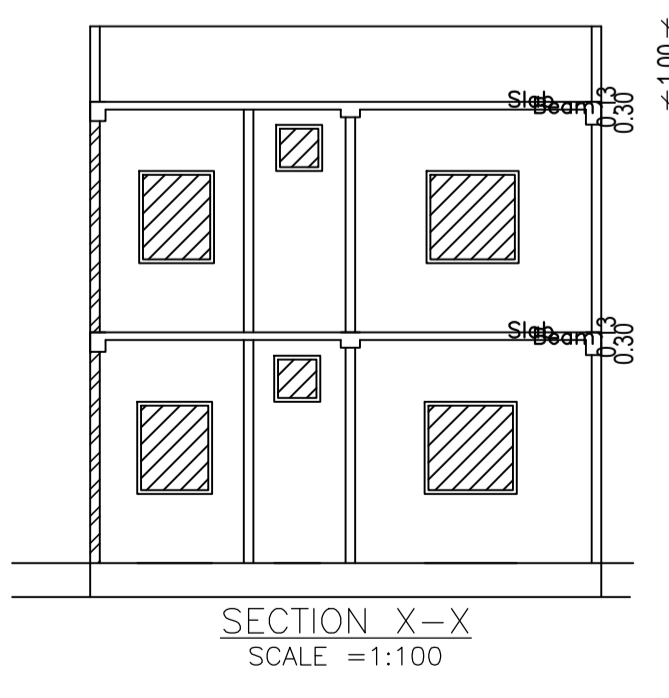
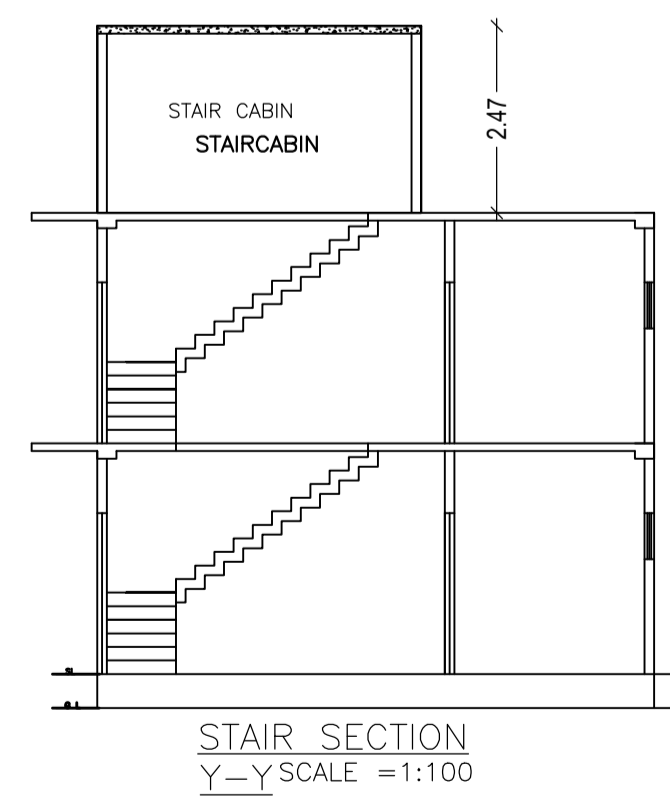
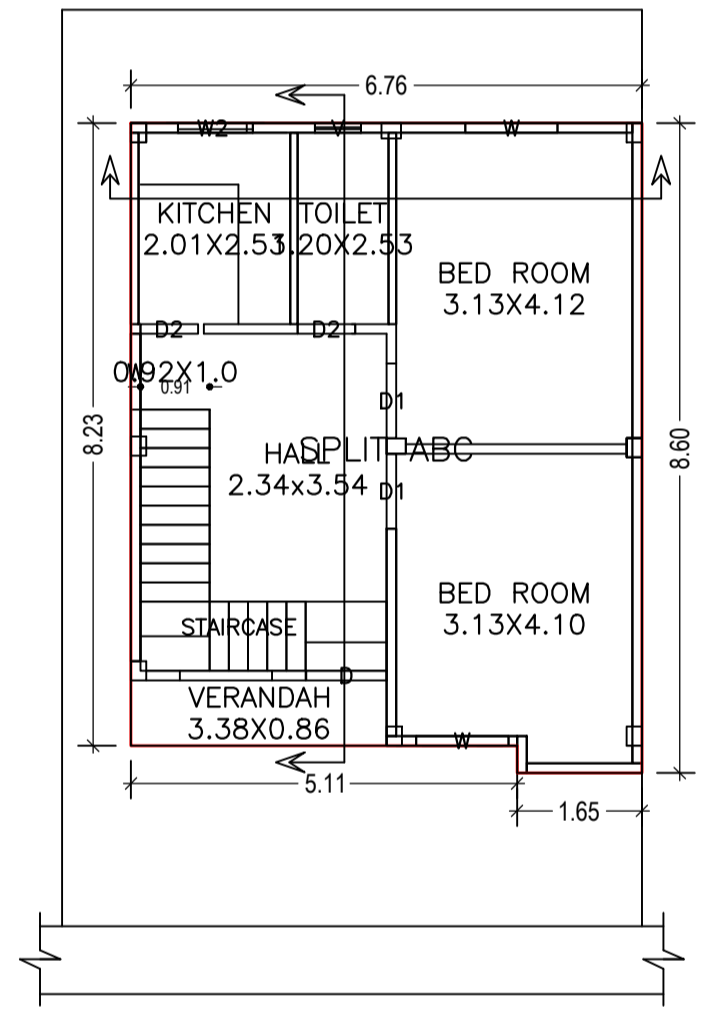
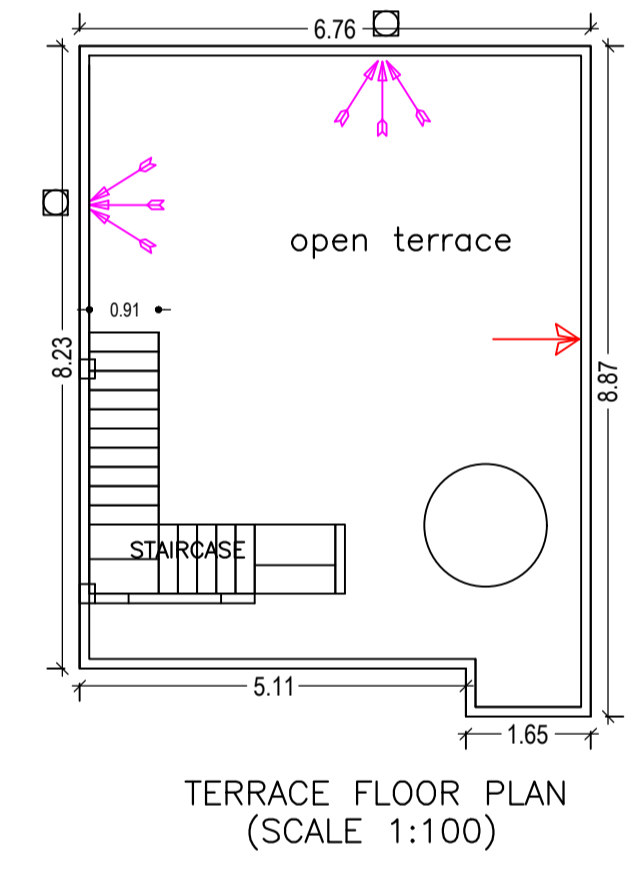
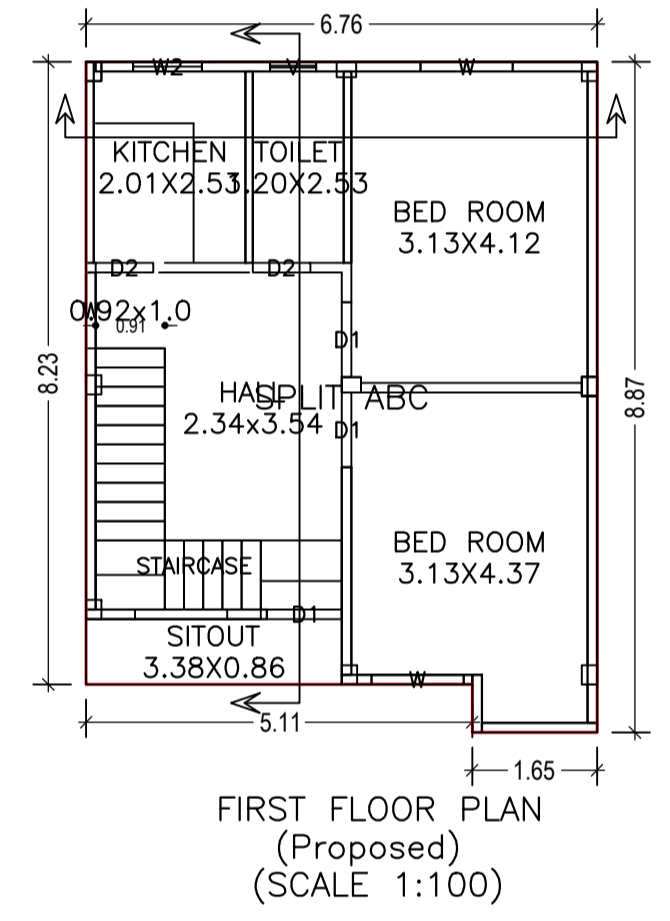
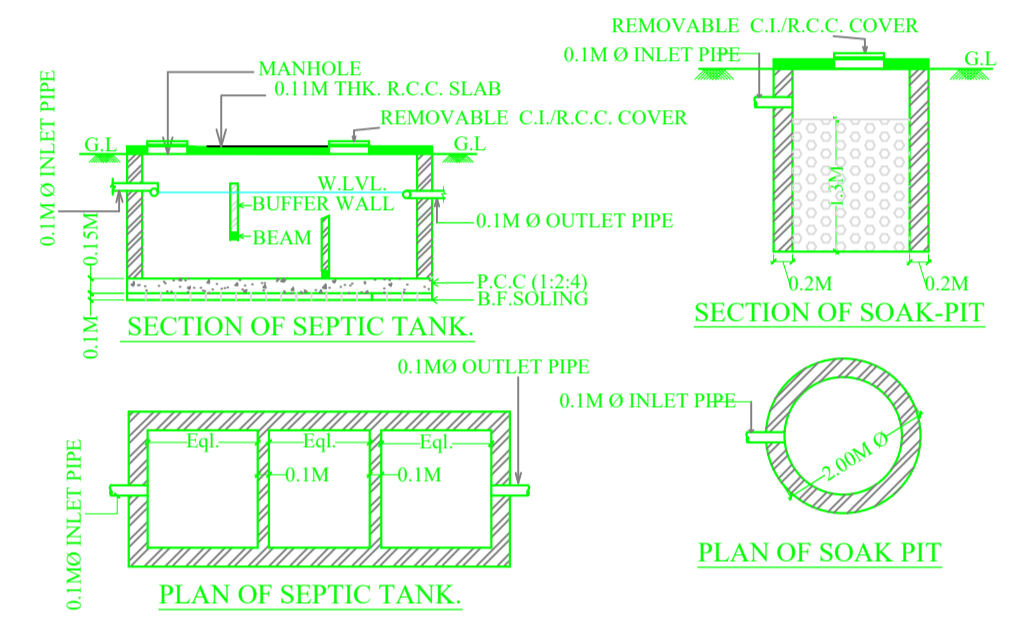
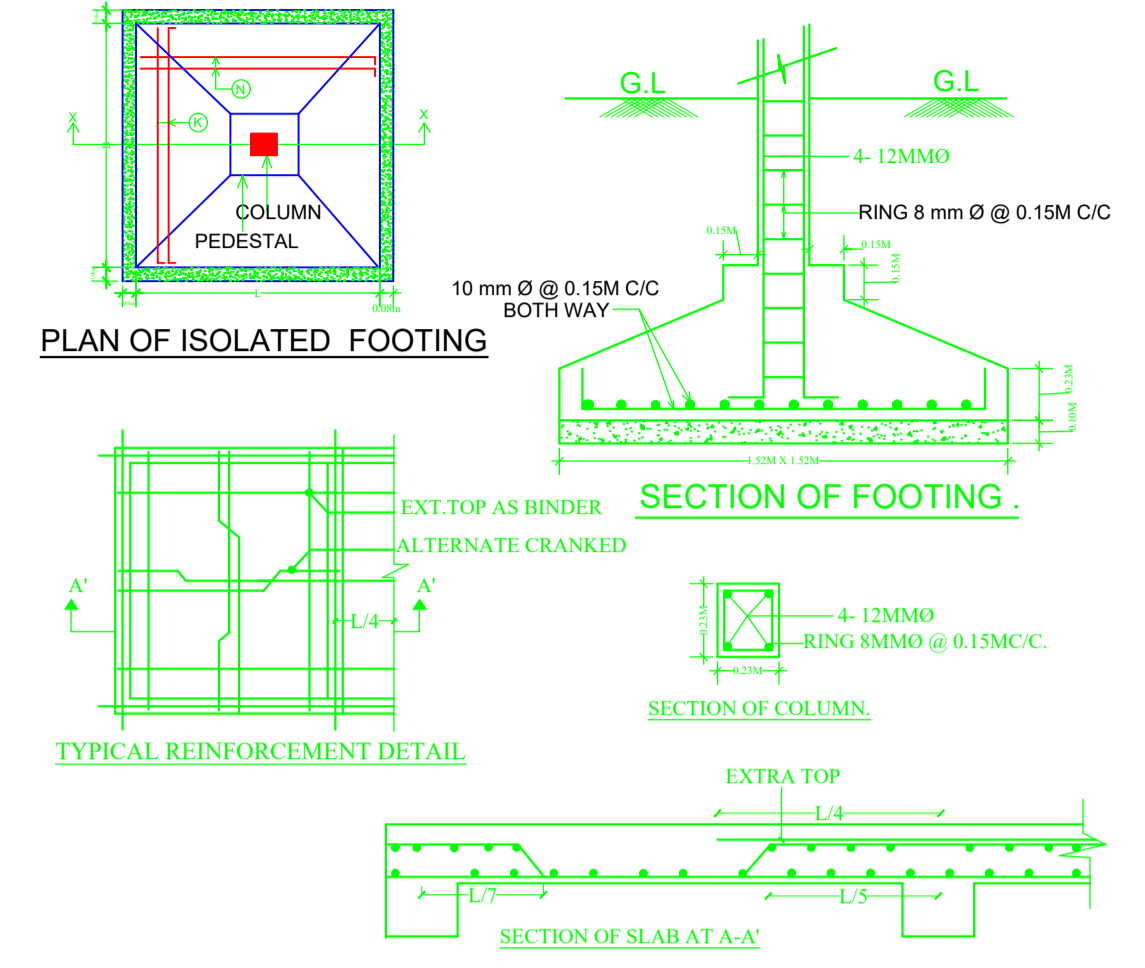
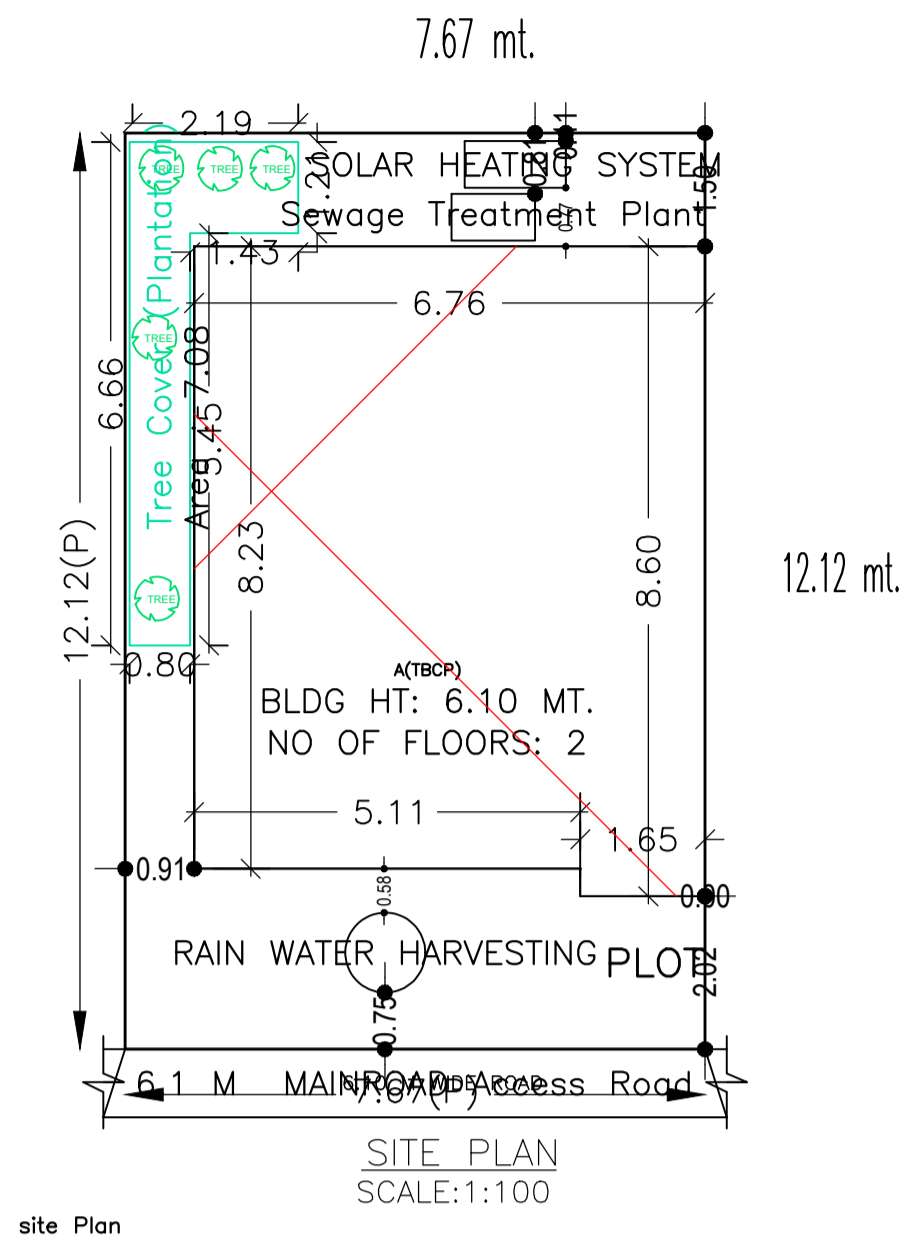
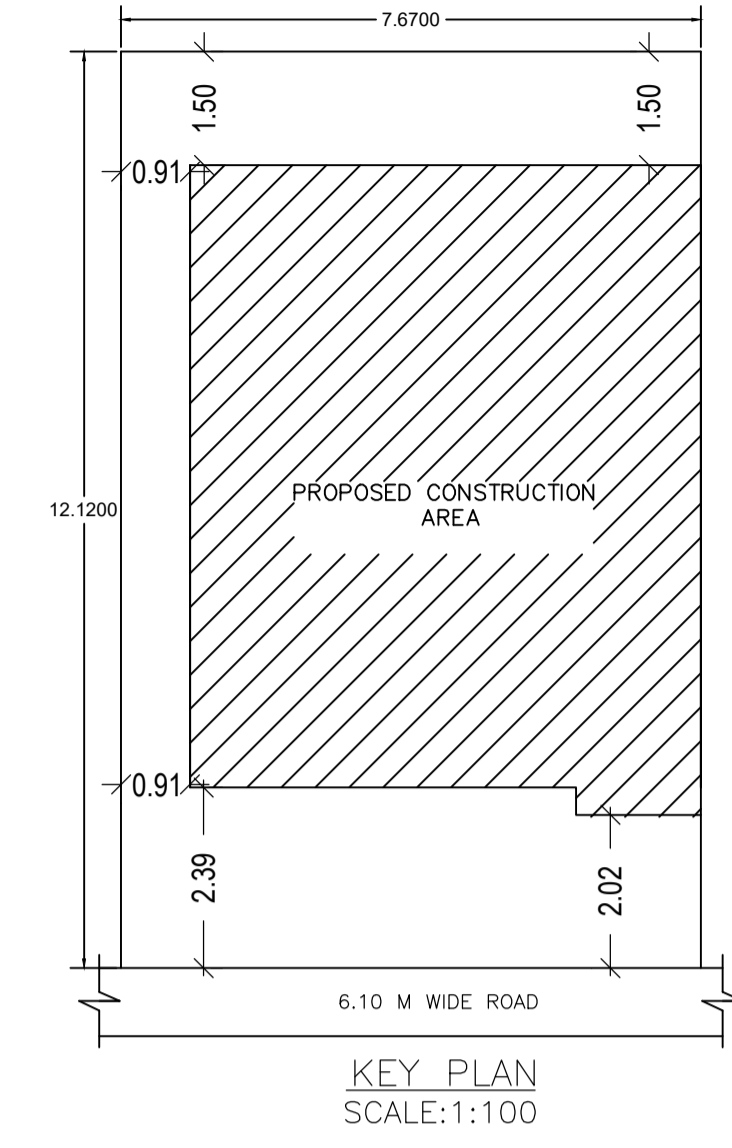
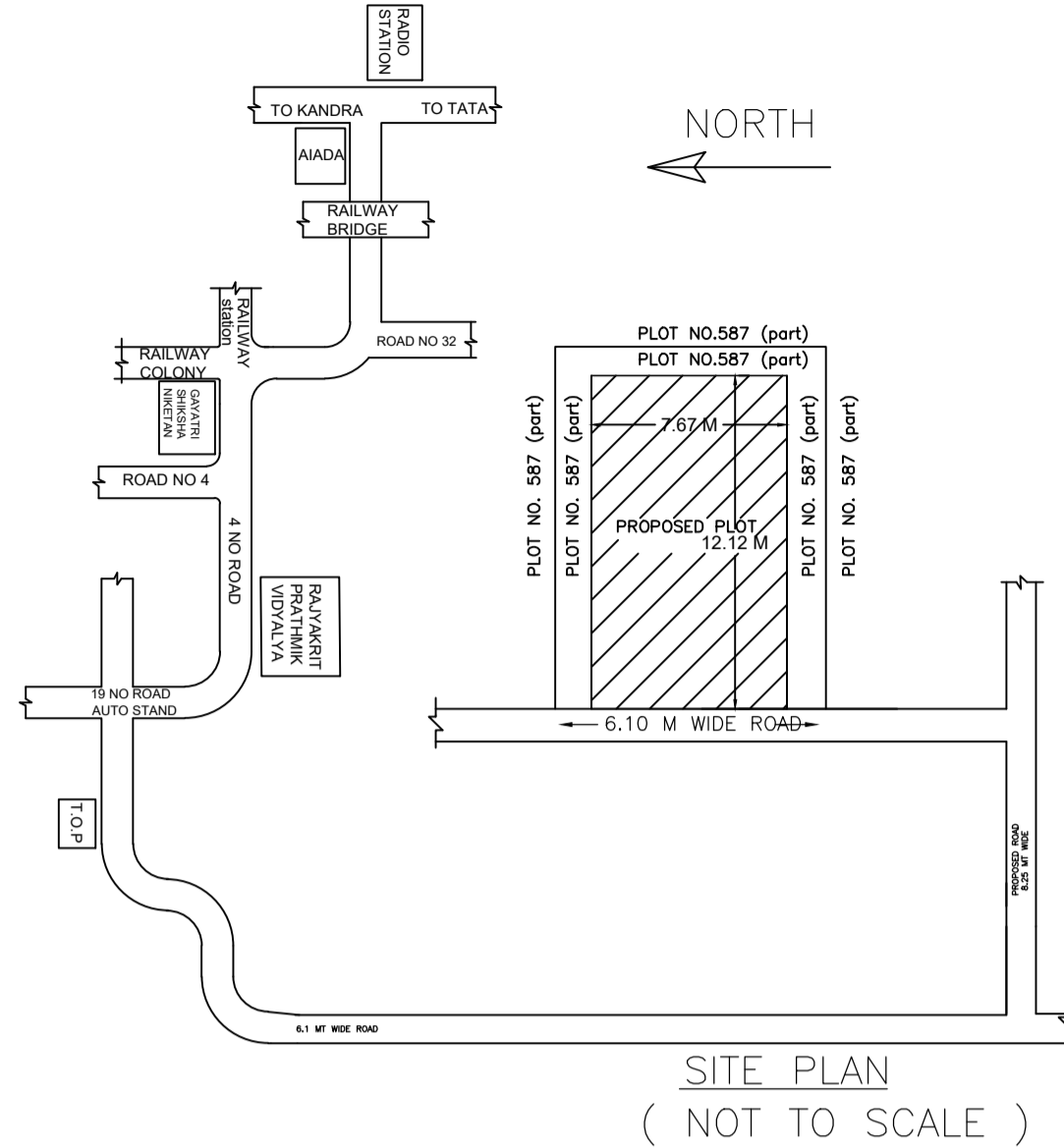

Building :A(TBCP)

Floor Name	Total Built Up Area (Sq.mt.)	Proposed FAR Area (Sq.mt.)	Total FAR Area (Sq.mt.)	Total Consumed Additional FAR Area (Sq.mt.)	Tnmt (No.)
Ground Floor	56.24	56.24	56.24	56.24	01
First Floor	56.69	56.69	56.69	56.69	00
Terrace Floor	0.00	0.00	0.00	0.00	00
Total :	112.93	112.93	112.93	112.93	01
Total Number of Same Buildings	1				
Total :	112.93	112.93	112.93	112.93	01

SCHEDULE OF DOOR:

BUILDING NAME	NAME	LENGTH	HEIGHT	NOS
A(TBCP)	D2	0.76	2.13	04
A(TBCP)	D1	0.99	2.13	05
A(TBCP)	D	1.06	2.13	01

SCHEDULE OF WINDOW/VENTILATION:

BUILDING NAME	NAME	LENGTH	HEIGHT	NOS
A(TBCP)	V	0.61	0.61	02
A(TBCP)	W2	0.91	1.20	02
A(TBCP)	W	1.00	1.20	02
A(TBCP)	W	1.22	1.20	04

AREA STATEMENT		VERSION NO.:	1.0.42
ADITYAPUR MUNICIPAL CORPORATION		VERSION DATE: 29/04/2019	
PROJECT DETAIL:			
Region: JHARKHAND URBAN LOCAL BODIES	Plot Use: Residential		
District: EAST SINGHBHUM	Plot SubUse: Bungalow/ Dwelling / Non Apartment		
Authority: ADITYAPUR MUNICIPAL CORPORATION	PlotNearby/ReligiousStructure: NA		
Inward No: AMC/BP/0048/W32/2019	Plot/SubPlot No: 587(OLD) & 1688, 1753, 1754, 1755 (NEW)		
Application Type: General Proposal	North Plot No. - 587 (PART)		
Project Type: Building Permission	South Plot No. - 587 (PART)		
Nature of Development: New	East Plot No. - 587 (PART)		
Location of Development Area: Old Area	West Road Width - 6.1		
AREA DETAILS:			
AREA OF PLOT (Minimum)	(A)	SQ.MT.	92.96
NET AREA OF PLOT(Gross Plot Area - Deduction from Gross Plot area)	(A-Deductions)		92.96
Deduction for Balance Plot Area(from Gross Plot Area)			
Common Plot			7.08
Total			7.08
BALANCE AREA OF PLOT(Net Plot Area - Recreational/Amenity space)	(A-Deductions)		85.88
PLOT AREA FOR COVERAGE(Net Plot Area)	(A-Deductions)		92.96
Plot Area for FAR (Net Plot Area + RoadWidening Area)	(A-Deductions)		92.96
COVERAGE CHECK			
Permissible Coverage area (70.00 %)			65.07
Proposed Coverage Area (60.50 %)			56.24
Total Prop. Coverage Area (60.5 %)			56.24
Balance coverage area (9.50 %)			8.83
FAR CHECK			
Perm. FAR Area (2.50)			232.40
Total Perm. FAR area			232.40
Residential FAR			112.93
Proposed FAR Area			112.93
Total Proposed FAR Area			112.93
Consumed FAR (Factor)			1.21
Balance FAR Area			119.47
BUILT UP AREA CHECK			
Total Proposed BuiltUp Area			112.93
ARCHITECT (Regd)			MOHAMMAD BELAL NASIR
ENGINEER (Regd)			
SUPERVISOR (Regd)			
OWNER (Regd)			Technoculture Building Centre Pvt. Ltd.
DEVELOPMENT AUTHORITY		LOCAL BODY	

COLOR INDEX		
PLOT BOUNDARY		Black
ABUTTING ROAD		Green
PROPOSED CONSTRUCTION		Red
COMMON PLOT		Yellow
ROAD WIDENING AREA		Blue
EXISTING (To be retained)		Orange
EXISTING (To be demolished)		White

Buildingwise Floor FAR Details

Floor Name	Building Name		Total	
	Proposed Built Up Area (Sq.mt.)	Proposed FAR Area (Sq.mt.)	Total Proposed Built Up Area (Sq.mt.)	Total FAR Area (Sq.mt.)
Ground Floor	56.24	56.24	56.24	56.24
First Floor	56.69	56.69	56.69	56.69
Terrace Floor	0.00	0.00	0.00	0.00
Total :	112.93	112.93	112.93	112.93

Building USE/SUBUSE Details

Building Name	Building Use	Building SubUse	Building Structure
A(TBCP)	Residential	Residential Bldg/Apartment	Non-Highrise

FAR & Tenement Details (Table 4c-1)

Building	No. of Same Bldg	Total Built Up Area (Sq.mt.)	Proposed FAR Area (Sq.mt.)	Total FAR Area (Sq.mt.)	Total Consumed Additional FAR Area (Sq.mt.)	Tnmt (No.)
A(TBCP)	1	112.93	112.93	112.93	112.93	01
Grand Total :	1	112.93	112.93	112.93	112.93	01

UnitBUA Table for Building :A(TBCP)

FLOOR	Name	UnitBUA Type	UnitBUA Area	Carpet Area	No. of Rooms	No. of Tenement
FIRST FLOOR PLAN	SPLIT ABC	FLAT	0.00	0.00	6	0
GROUND FLOOR PLAN	SPLIT ABC	FLAT	112.93	104.44	6	1
Total:	-	-	112.93	104.44	12	1

LTP NAME AND SIGNATURE	STRUCTURAL ENG'S NAME AND SIGNATURE	BUILDER NAME AND SIGNATURE	DIGITAL SIGNATURE
MOHAMMAD BELAL NASIR AMC/ENG/0015/2017			