

Proposal Basic Information

Proposal File No.	AMC/BP/0036/W22/2020
Owner Name	Technoculture Building Centre Pvt. Ltd.
Khata No	48(OLD), 110(NEW)
Plot No	456(OLD), 2481(NEW)
Village Name	ASANGI
Use	Residential
SubUse	Bungalow/ Dwelling / Non Apartment

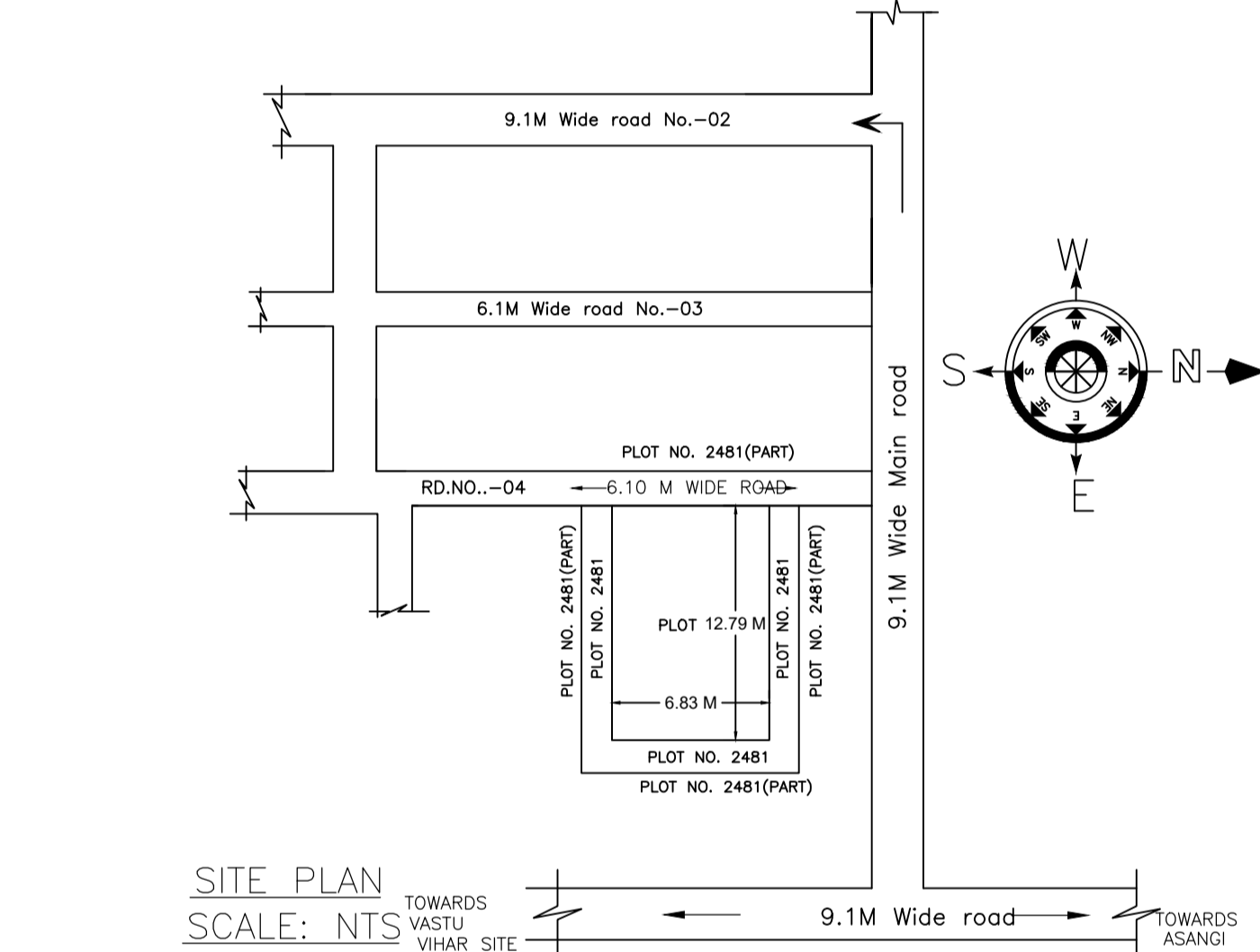

AREA STATEMENT	ADITYAPUR MUNICIPAL CORPORATION	VERSION NO.: 1.0.60	SQ.MT.
PROJECT DETAIL:	Region: JHARKHAND URBAN LOCAL BODIES	VERSION DATE: 16/10/2020	
	District: EAST SINGHBHUM	Plot Use: Residential	
	Authority: ADITYAPUR MUNICIPAL CORPORATION	Plot SubUse: Bungalow/ Dwelling / Non Apartment	
	Inward No: AMC/BP/0036/W22/2020	Plot/Nearby Religious Structure: NA	
	Application Type: General Proposal	Plot/SubPlot No: 456(OLD), 2481(NEW)	
	Project Type: Building Permission	North: Plot No. - 2481 PART	
	Nature of Development: New	South: Plot No. - 2481 PART	
	Location of Development Area: Old Area	East: Plot No. - 2481 PART	
		West: Road Width - 6.1	
AREA DETAILS:			
AREA OF PLOT (Minimum)	(A)		87.35
NET AREA OF PLOT(Gross Plot Area - Deduction from Gross Plot area)	(A-Deductions)		87.35
Deduction for Balance Plot Area(from Gross Plot Area)			
Common Plot			7.44
Total			7.44
BALANCE AREA OF PLOT(Net Plot Area - Recreational/Amenity space)	(A-Deductions)		79.91
PLOT AREA FOR COVERAGE(Net Plot Area)	(A-Deductions)		87.35
Plot Area for FAR (Net Plot Area + Road/Widening Area)	(A-Deductions)		87.35
COVERAGE CHECK			
Permissible Coverage area (70.00 %)			61.14
Proposed Coverage Area (62.90 %)			54.94
Total Prop. Coverage Area (62.9 %)			54.94
Balance coverage area (7.10 %)			6.20
FAR CHECK			
Perm. FAR Area (2.50)			218.38
Total Perm. FAR area			218.38
Residential FAR			115.73
Proposed FAR Area			115.73
Total Proposed FAR Area			115.73
Consumed FAR (Factor)			1.32
Balance FAR Area			102.65
BUILT UP AREA CHECK			
Total Proposed BuiltUp Area			115.73
ARCHITECT (Regd)			MOHAMMAD BELAL NASIR
ENGINEER (Regd)			
SUPERVISOR (Regd)			
OWNER (Regd)			Technoculture Building Centre Pvt. Ltd.
DEVELOPMENT AUTHORITY LOCAL BODY			

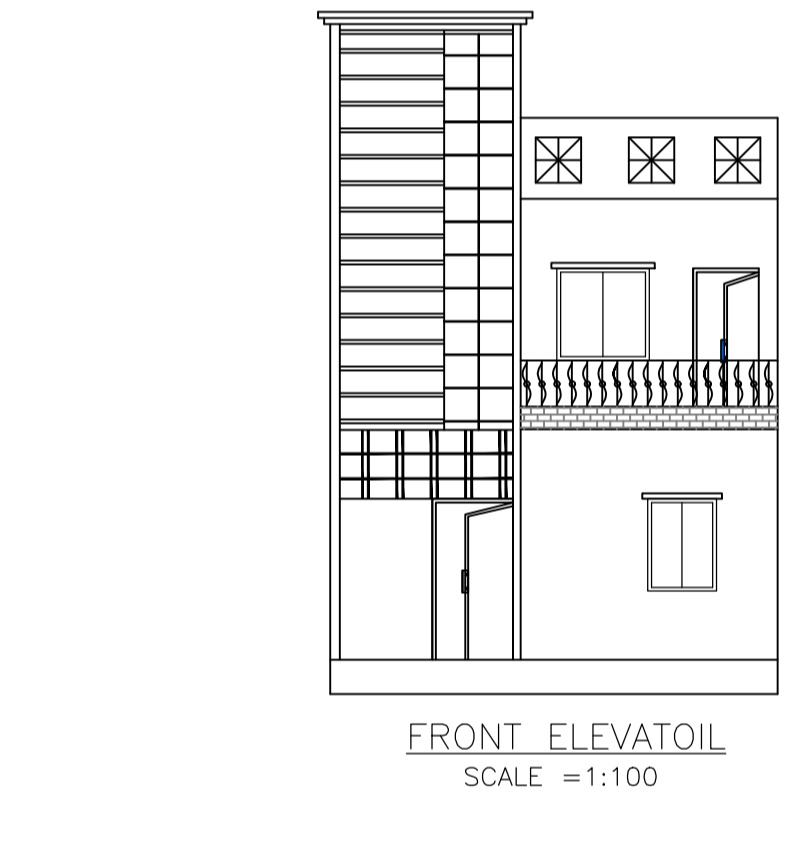
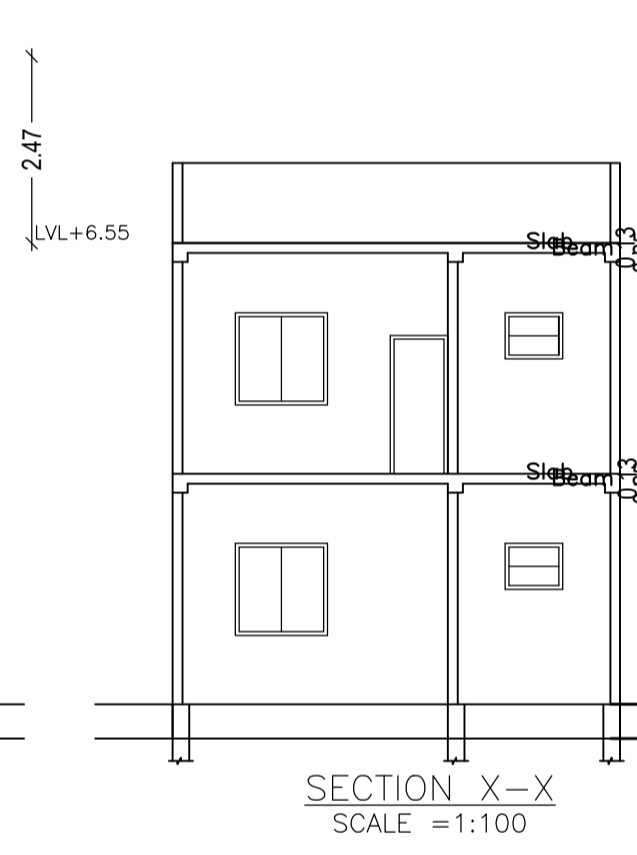
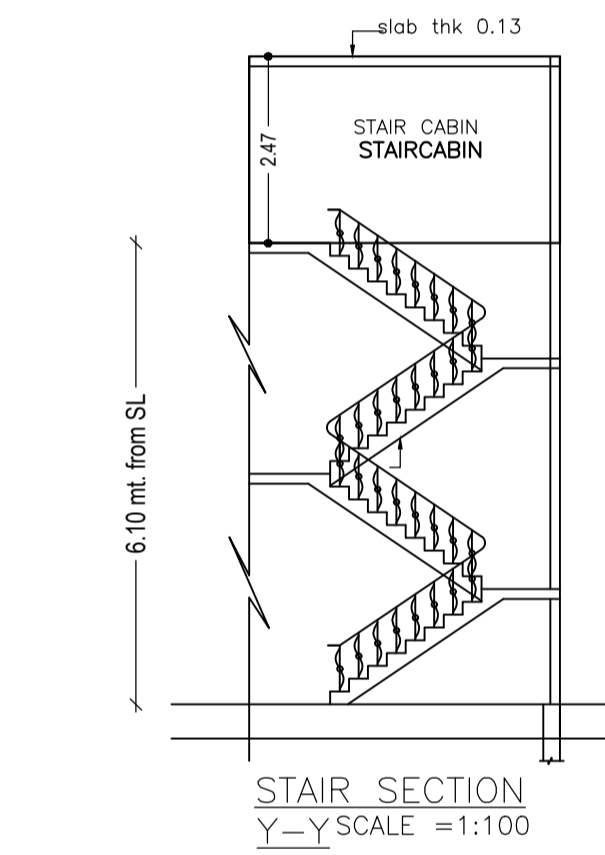
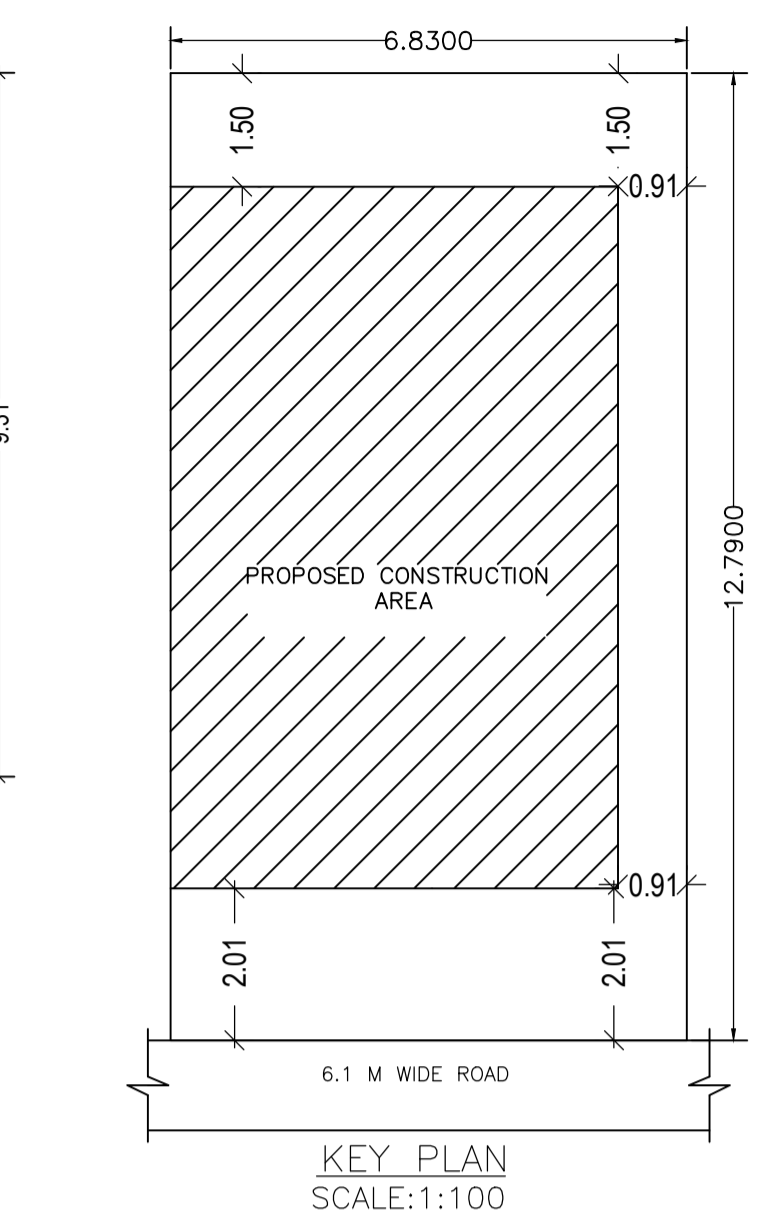
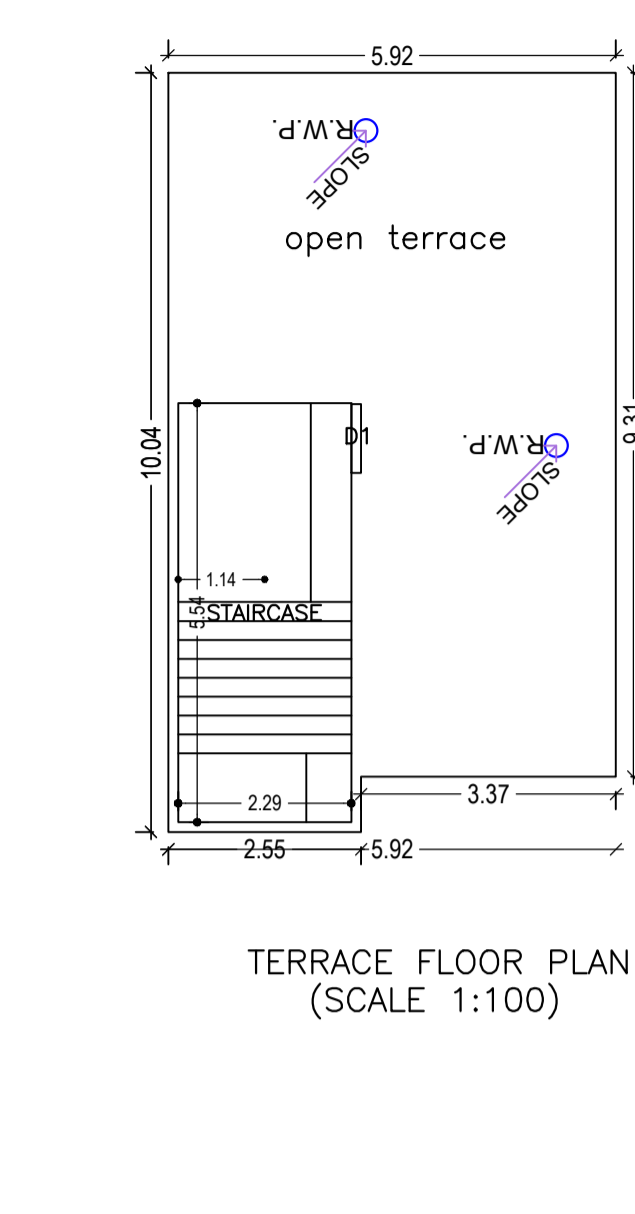
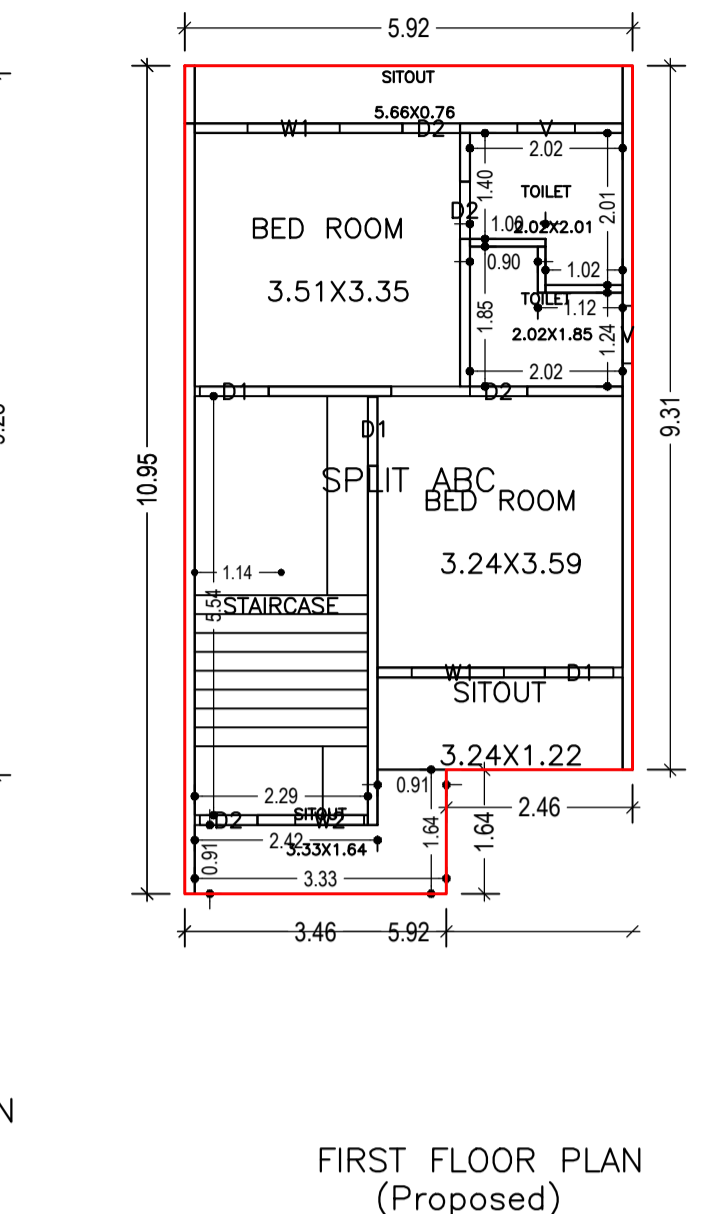
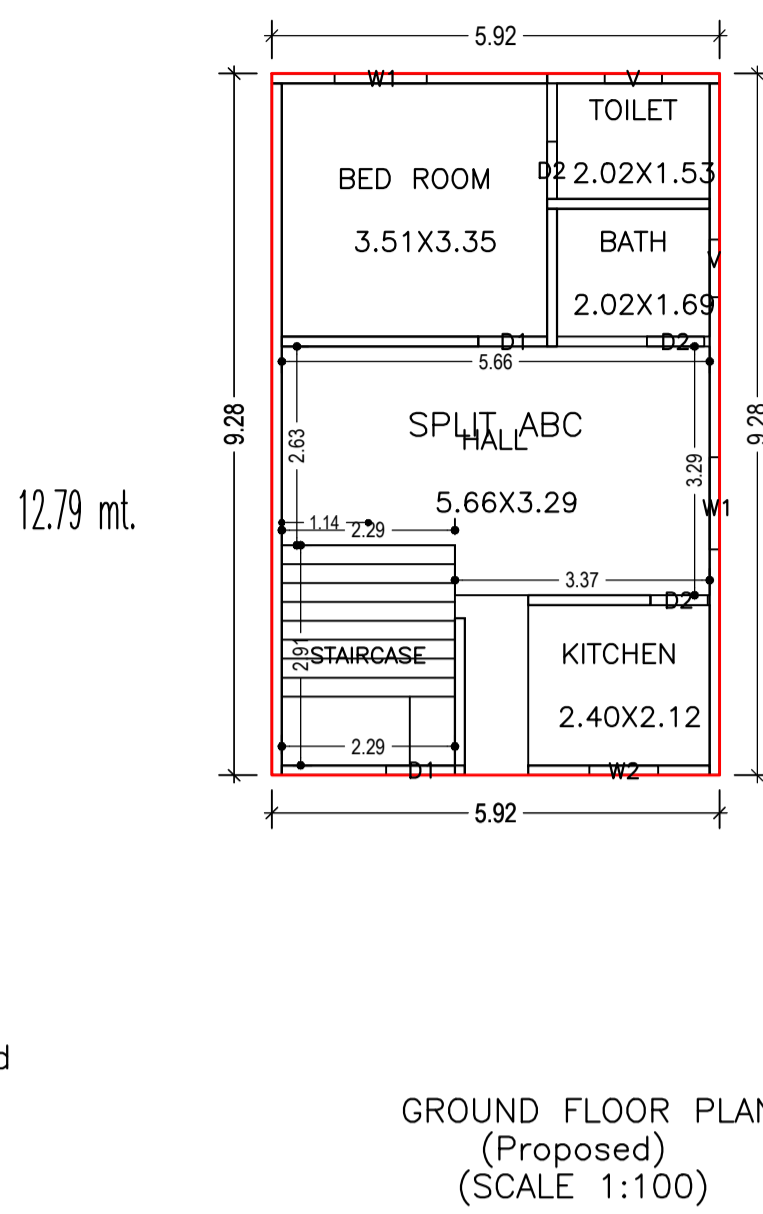
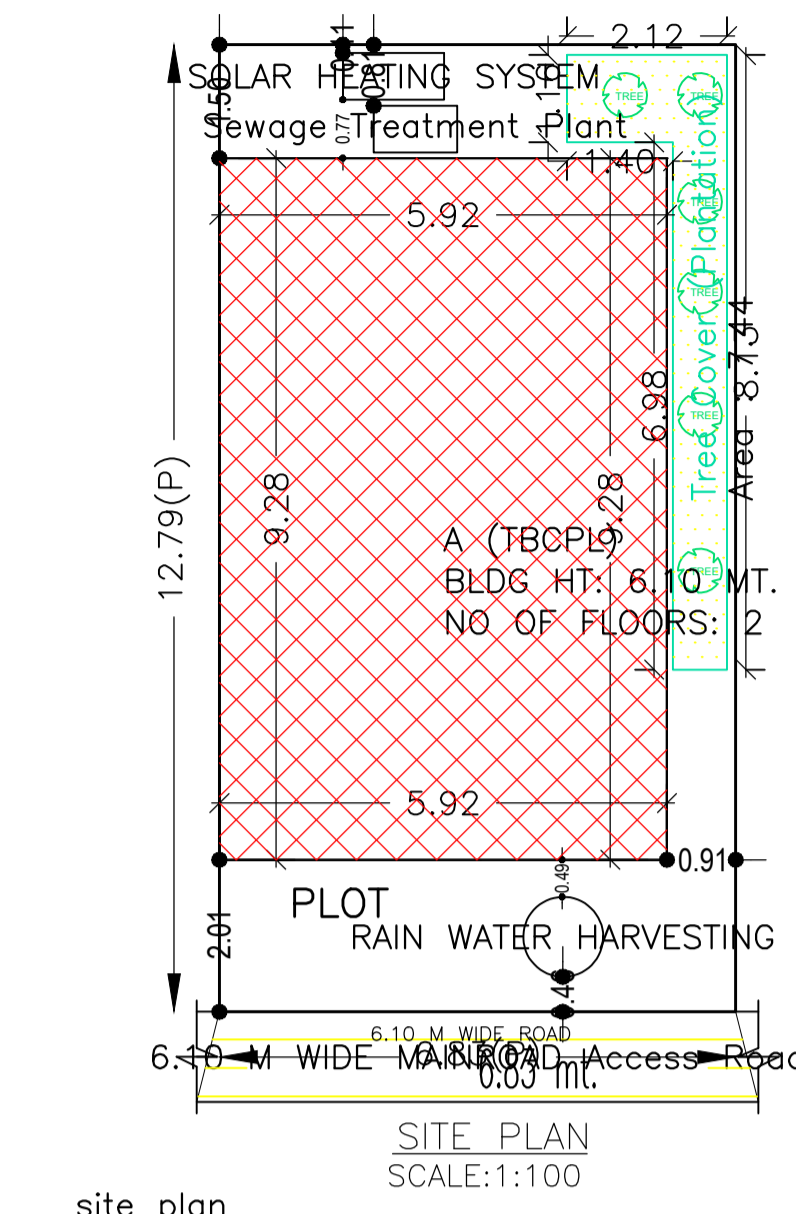
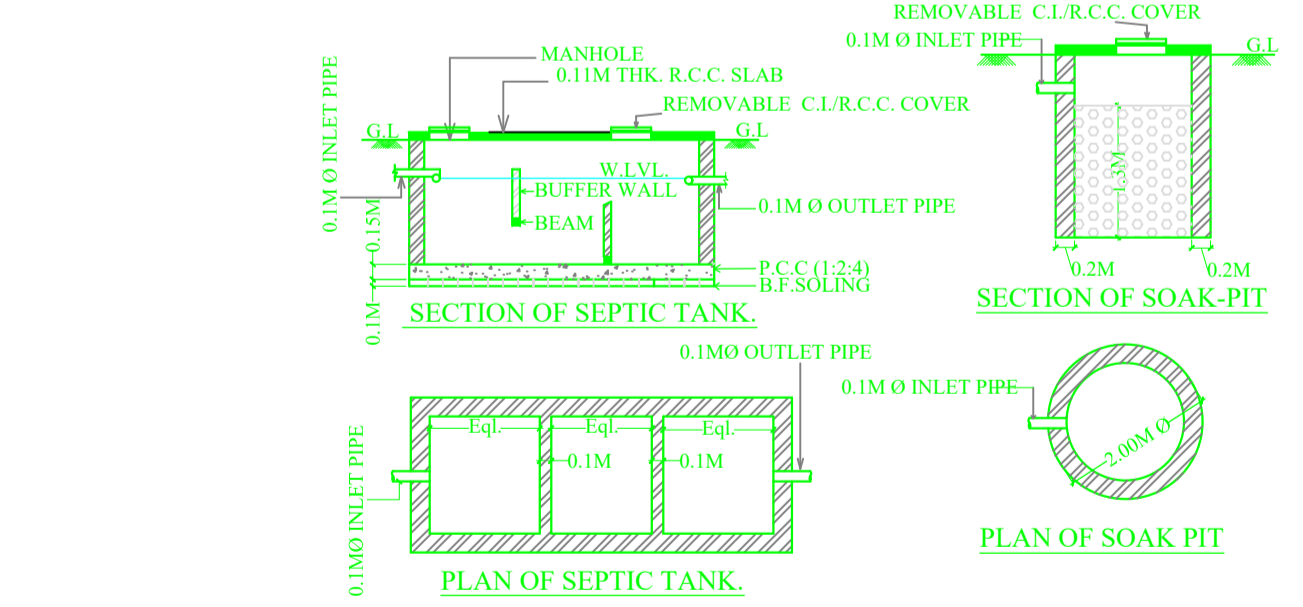

Building :A (TBCPL)

Floor Name	Total Built Up Area (Sq.mt.)	Proposed FAR Area (Sq.mt.) Resi.	Total FAR Area (Sq.mt.)	Total Consumed Additional FAR Area (Sq.mt.)	Tnmt (No.)
Ground Floor	54.94	54.94	54.94	54.94	01
First Floor	60.79	60.79	60.79	60.79	00
Terrace Floor	0.00	0.00	0.00	0.00	00
Total :	115.73	115.73	115.73	115.73	01
Total Number of Same Buildings :	1				
Total :	115.73	115.73	115.73	115.73	01

SCHEDULE OF DOOR:

BUILDING NAME	NAME	LENGTH	HEIGHT	NOS
A (TBCPL)	D2	0.76	2.13	07
A (TBCPL)	D1	0.91	2.13	04

SCHEDULE OF WINDOW/VENTILATION:

BUILDING NAME	NAME	LENGTH	HEIGHT	NOS
A (TBCPL)	V	0.76	0.61	04
A (TBCPL)	W2	0.91	1.22	02
A (TBCPL)	W1	1.22	1.22	04

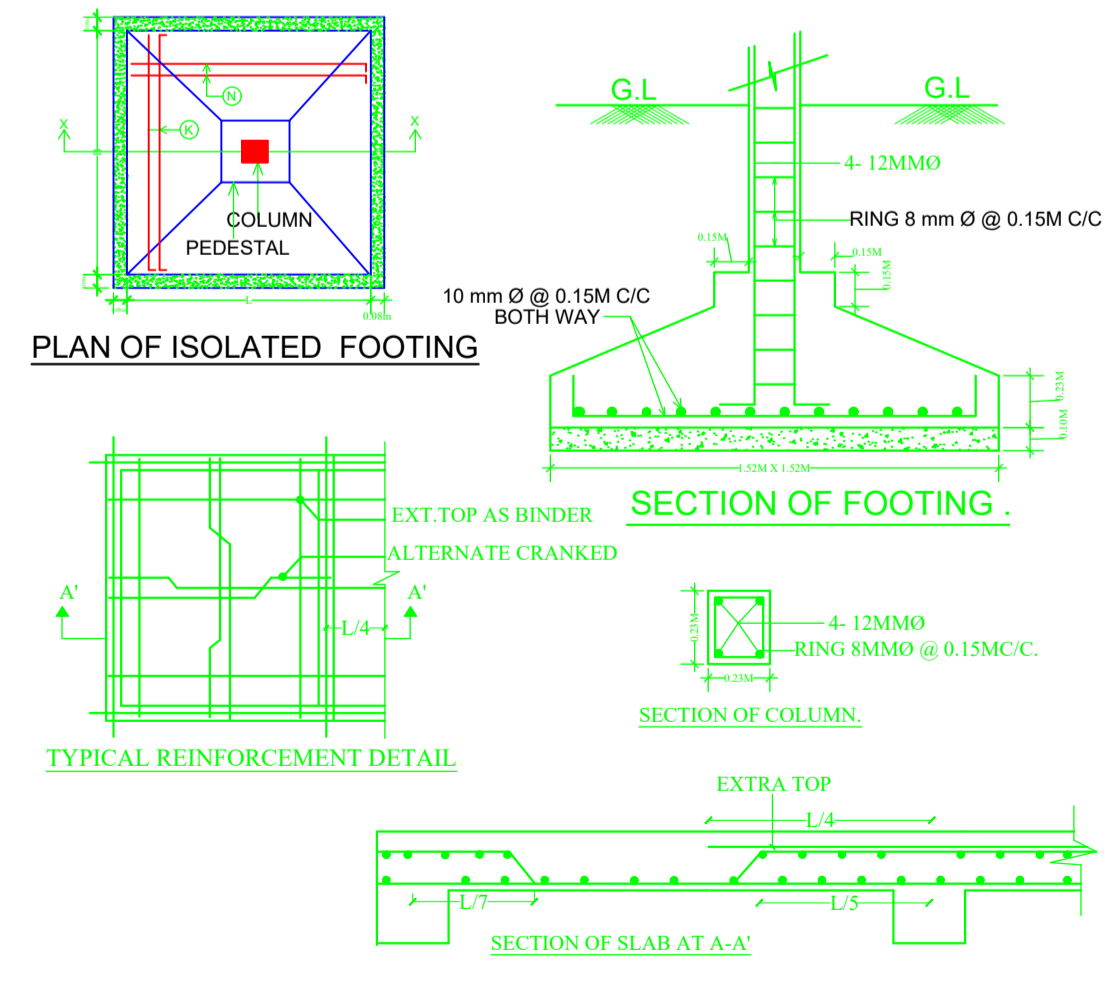

COLOR INDEX

PLOT BOUNDARY	Black
ABUTTING ROAD	Green
PROPOSED CONSTRUCTION	Red
COMMON PLOT	Yellow
ROAD WIDENING AREA	Blue
EXISTING (To be retained)	Blue
EXISTING (To be demolished)	Yellow

Buildingwise Floor FAR Details

Floor Name	Building Name A (TBCPL)		Total	
	Proposed Built Up Area (Sq.mt.)	Proposed FAR Area (Sq.mt.)	Total Proposed Built Up Area (Sq.mt.)	Total FAR Area (Sq.mt.)
Ground Floor	54.94	54.94	54.94	54.94
First Floor	60.79	60.79	60.79	60.79
Terrace Floor	0.00	0.00	0.00	0.00
Total :	115.73	115.73	115.73	115.73

Building USE/SUBUSE Details

Building Name	Building Use	Building SubUse	Building Structure
A (TBCPL)	Residential	Residential Bldg/Apartment	Non-Highrise

FAR & Tenement Details (Table 4c-1)

Building	No. of Same Bldg	Total Built Up Area (Sq.mt.)	Proposed FAR Area (Sq.mt.) Resi.	Total FAR Area (Sq.mt.)	Total Consumed Additional FAR Area (Sq.mt.)	Tnmt (No.)
A (TBCPL)	1	115.73	115.73	115.73	115.73	01
Grand Total :	1	115.73	115.73	115.73	115.73	01

UnitBUA Table for Building :A (TBCPL)

FLOOR	Name	UnitBUA Type	UnitBUA Area	Carpet Area	No. of Rooms	No. of Tenement
GROUND FLOOR PLAN	SPLIT ABC	FLAT	115.73	105.28	5	1
FIRST FLOOR PLAN	SPLIT ABC	FLAT	0.00	0.00	7	0
Total :	-	-	115.73	105.28	12	1

LTP NAME AND SIGNATURE	STRUCTURAL ENG'S NAME AND SIGNATURE	BUILDER NAME AND SIGNATURE	DIGITAL SIGNATURE
MOHAMMAD BELAL NASIR AMC/ENG/0015/2017			