

Proposal Basic Information	
Proposal File No.	AMC/BP/0004/W22/2020
Owner Name	MUKESH KUMAR SINGH
Khata No	222
Plot No	1213
Village Name	ASANGI
Use	Residential
SubUse	Semidetached

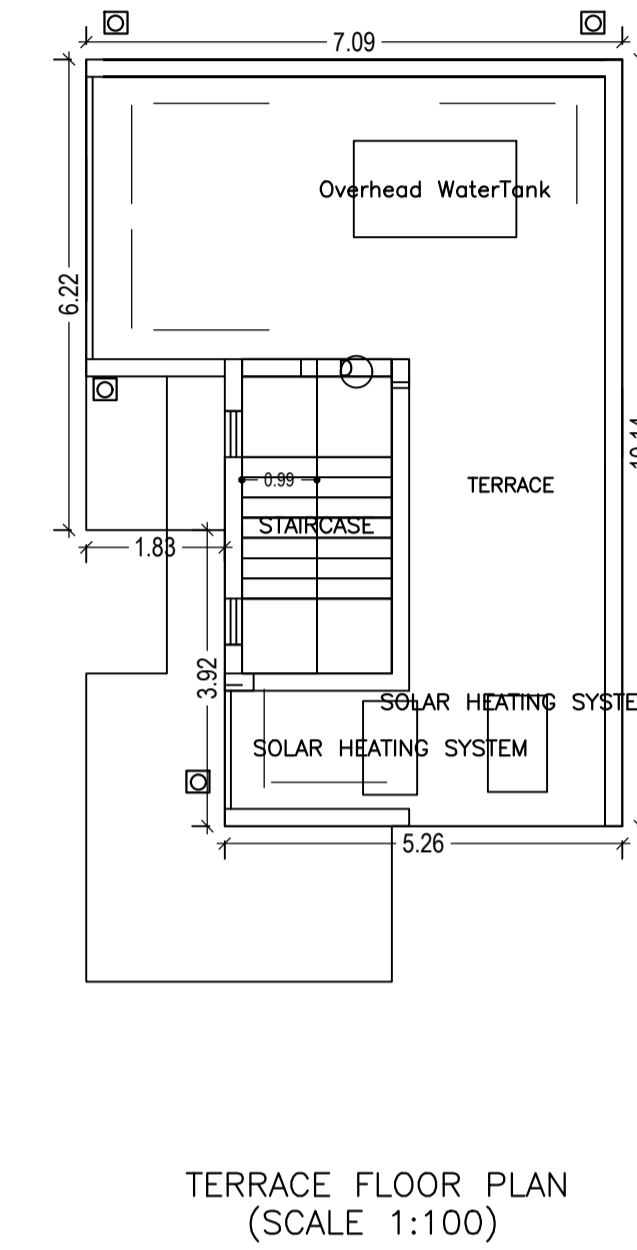

AREA STATEMENT		VERSION NO.: 1.0.46
ADITYAPUR MUNICIPAL CORPORATION		VERSION DATE: 22/06/2020
PROJECT DETAIL:		
Region: JHARKHAND URBAN LOCAL BODIES	Plot Use: Residential	
District: EAST SINGHBHUM	Plot SubUse: Semidetached	
Authority: ADITYAPUR MUNICIPAL CORPORATION	PlotNearby/ReligiousStructure: NA	
Inward No: AMC/BP/0004/W22/2020	Plot/SubPlot No: 1213	
Application Type: General Proposal	North: Road Width - 6.1	
Project Type: Building Permission	South: Plot No. - DLX205	
Nature of Development: New	East: Plot No. - DLX203	
Location of Development Area: Old Area	West: Road Width - 6.1	
AREA DETAILS:		
AREA OF PLOT (Minimum)	(A)	SQ.MT. 109.35
NET AREA OF PLOT(Gross Plot Area - Deduction from Gross Plot area)	(A-Deductions)	109.35
Deduction for Balance Plot Area(from Gross Plot Area)		
Common Plot		13.15
Total		13.15
BALANCE AREA OF PLOT(Net Plot Area - Recreational/Amenity space)	(A-Deductions)	96.20
PLOT AREA FOR COVERAGE(Net Plot Area)	(A-Deductions)	109.35
Plot Area for FAR (Net Plot Area + RoadWidening Area)	(A-Deductions)	109.35
COVERAGE CHECK		
Permissible Coverage area ( 70.00 % )		76.54
Proposed Coverage Area ( 59.21 % )		64.74
Total Prop. Coverage Area ( 59.21 % )		64.74
Balance coverage area ( 10.79 % )		11.80
FAR CHECK		
Perm. FAR Area ( 2.50 )		273.38
Total Perm. FAR area		273.38
Residential FAR		96.51
Proposed FAR Area		96.51
Total Proposed FAR Area		96.51
Consumed FAR (Factor)		0.88
Balance FAR Area		176.87
BUILT UP AREA CHECK		
Total Proposed BuiltUp Area		129.49
ARCHITECT (Regd)	Abhishek Tewari	
ENGINEER (Regd)		
SUPERVISOR (Regd)		
OWNER (Regd)	MUKESH KUMAR SINGH	
DEVELOPMENT AUTHORITY		LOCAL BODY

SITEPLAN

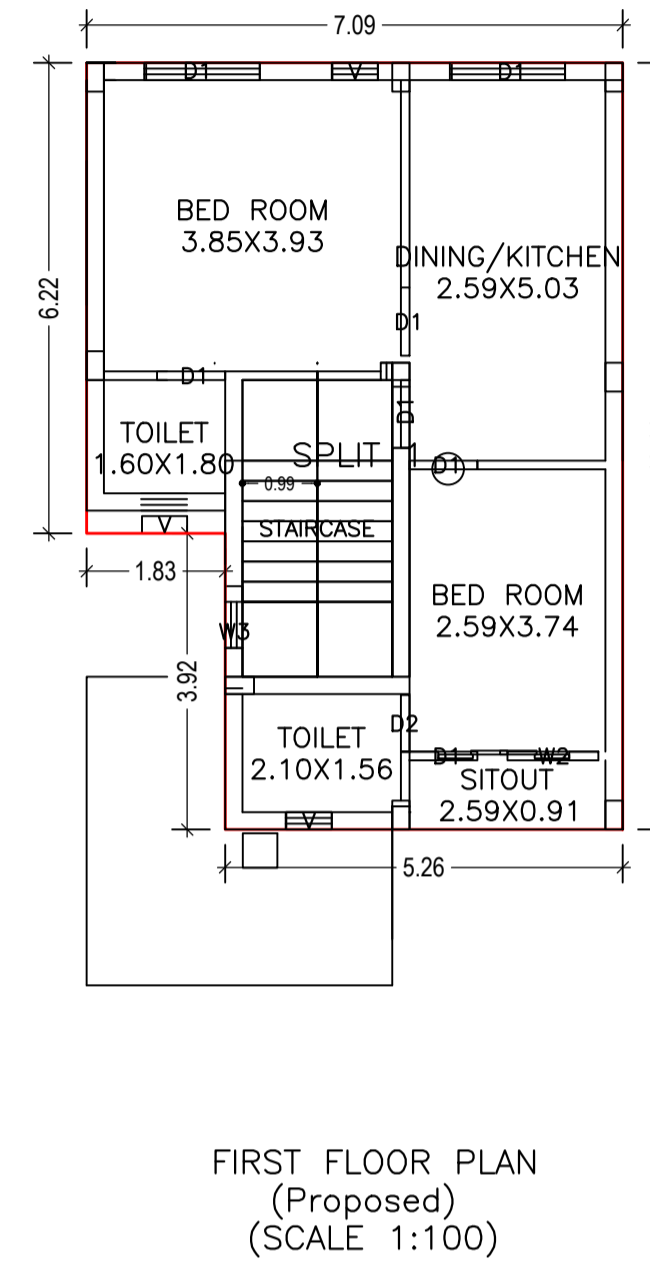
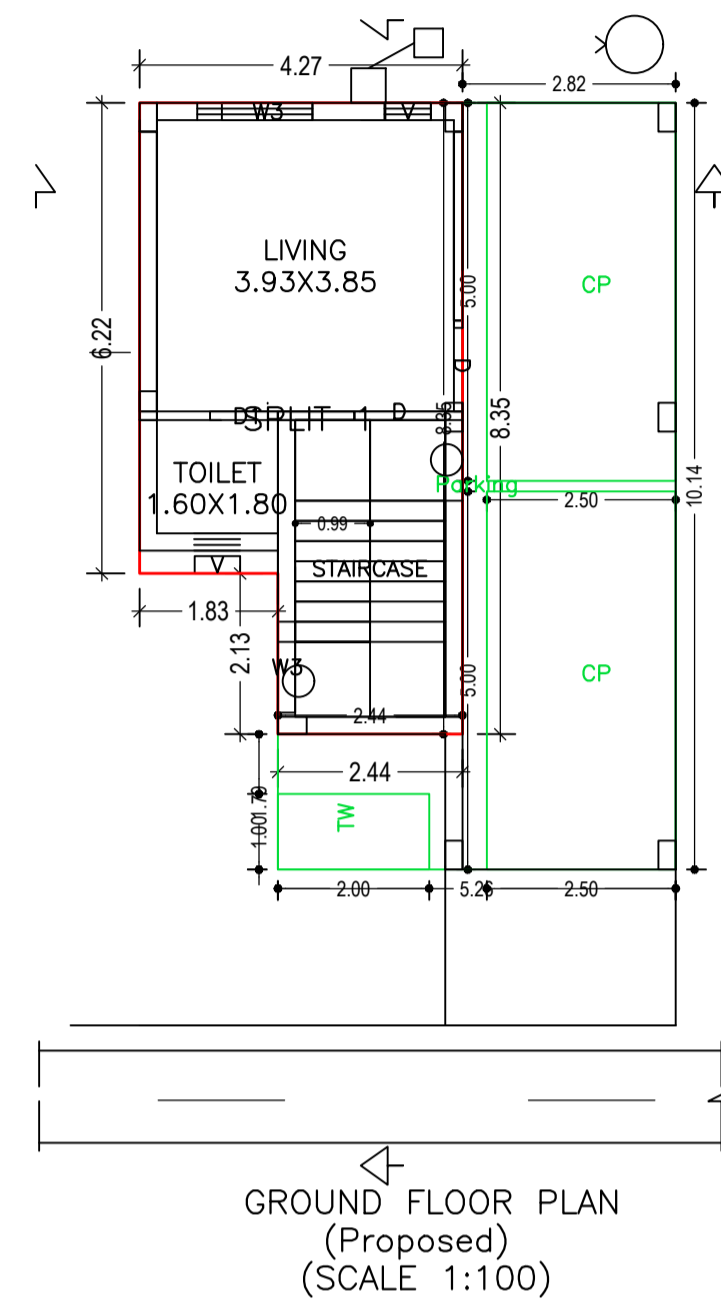
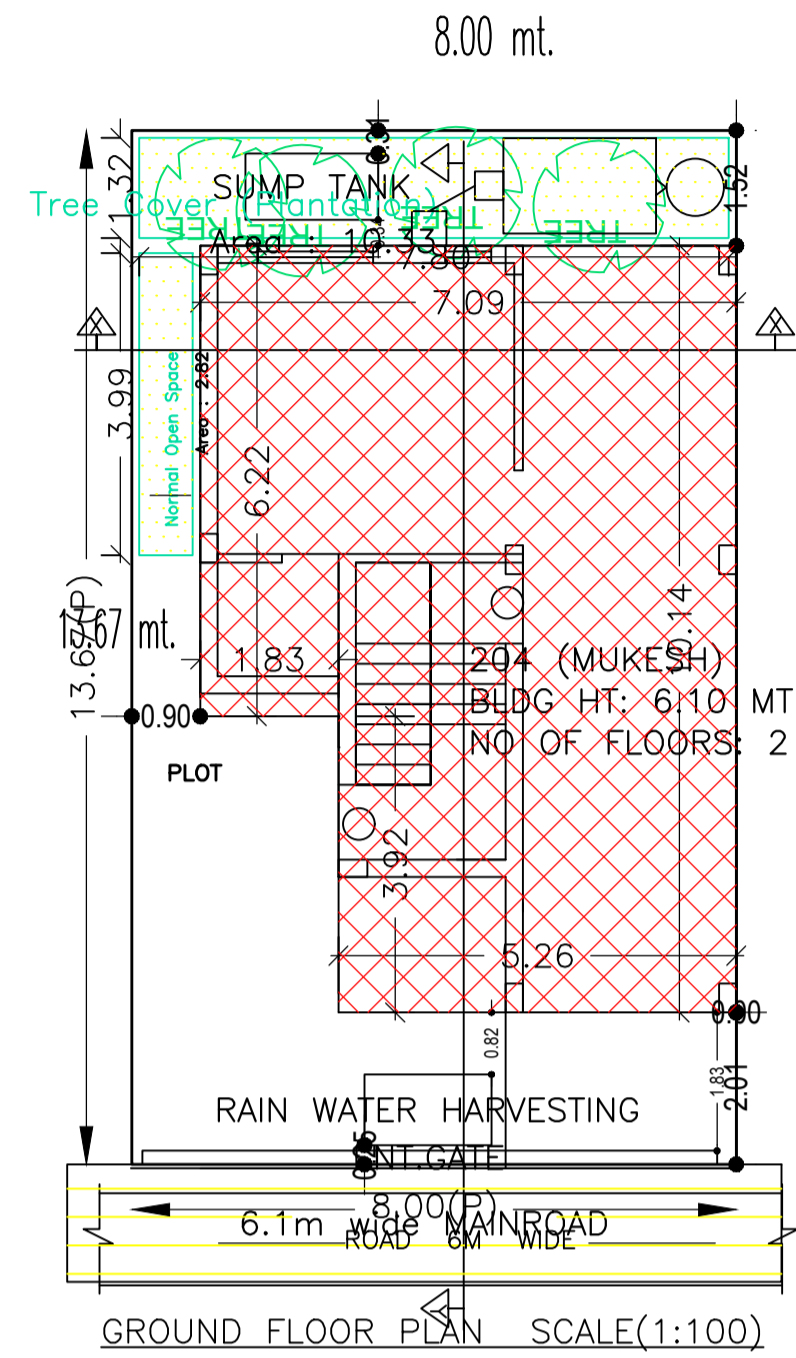
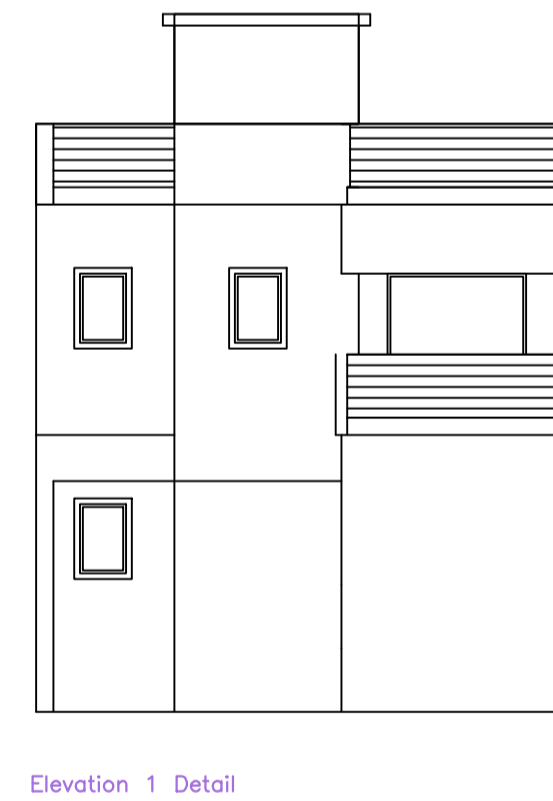
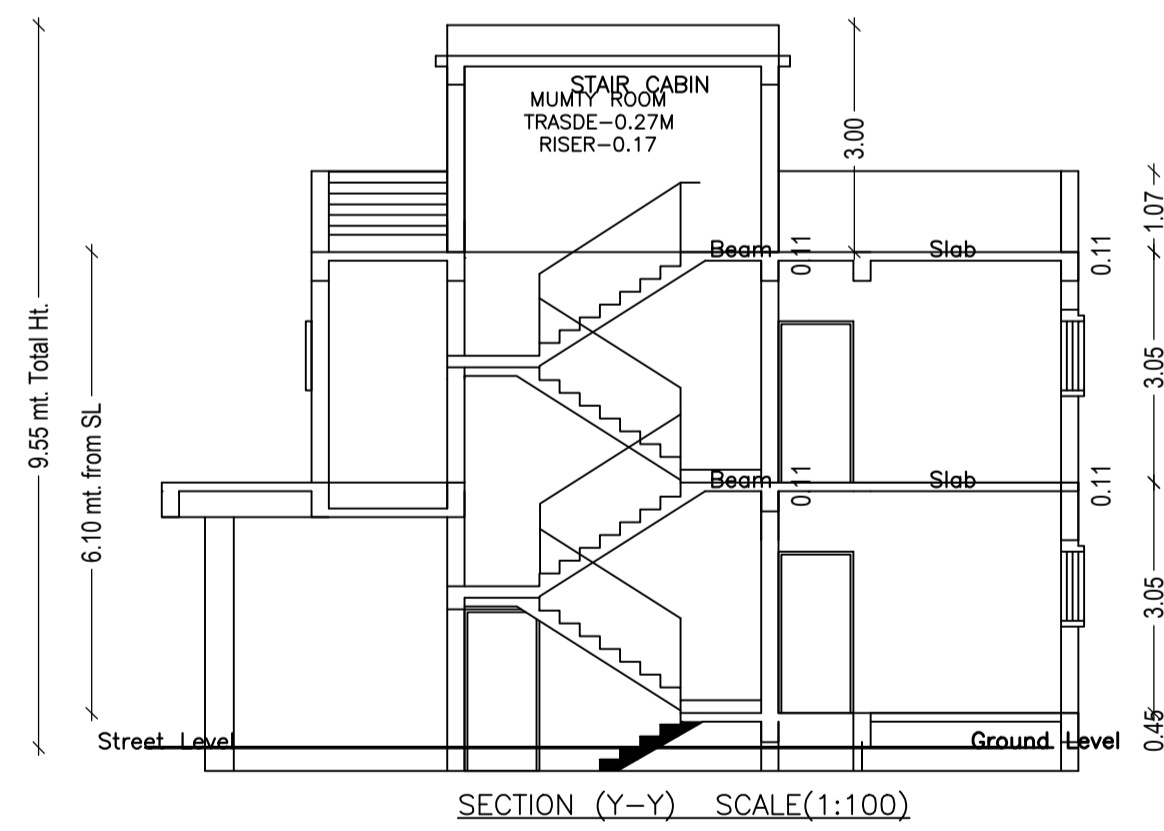

COLOR INDEX	
PLOT BOUNDARY	Black
ABUTTING ROAD	Green
PROPOSED CONSTRUCTION	Red
COMMON PLOT	Yellow
ROAD WIDENING AREA	Orange
EXISTING (To be retained)	Blue
EXISTING (To be demolished)	Light Blue

Buildingwise Floor FAR Details

Floor Name	Building Name		Total	
	204 (MUKESH)		Total Proposed Built Up Area (Sq.mt.)	Total FAR Area (Sq.mt.)
Ground Floor	64.74	31.76	64.74	31.76
First Floor	64.75	64.75	64.75	64.75
Terrace Floor	0.00	0.00	0.00	0.00
Total :	129.49	96.51	129.49	96.51

FAR & Tenement Details (Table 4c-1)

Building	No. of Same Bldg	Total Built Up Area (Sq.mt.)	Deductions (Area in Sq.mt.)		Proposed FAR Area (Sq.mt.)	Total FAR Area (Sq.mt.)	Total Consumed Additional FAR Area (Sq.mt.)	Trnmt (No.)
			Parking	Resi.				
204 (MUKESH)	1	129.49	32.98		96.51	96.51	96.51	01
Grand Total :	1	129.49	32.98		96.51	96.51	96.51	01

Building USE/SUBUSE Details

Building Name	Building Use	Building SubUse	Building Structure
204 (MUKESH)	Residential	Semidetached	Non-Highrise

LTP NAME AND SIGNATURE	STRUCTURAL ENG'S NAME AND SIGNATURE	BUILDER NAME AND SIGNATURE	DIGITAL SIGNATURE
Abhishek Tewari AMC/ARC/0026/2016			

Proposal Basic Information	
Proposal File No.	AMC/BP/0004/W22/2020
Owner Name	MUKESH KUMAR SINGH
Khata No	222
Plot No	1213
Village Name	ASANGI
Use	Residential
SubUse	Semidetached

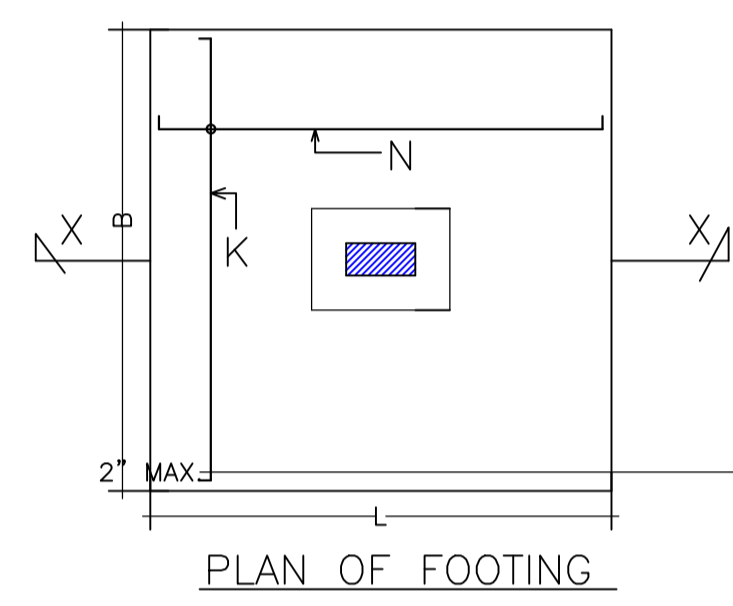
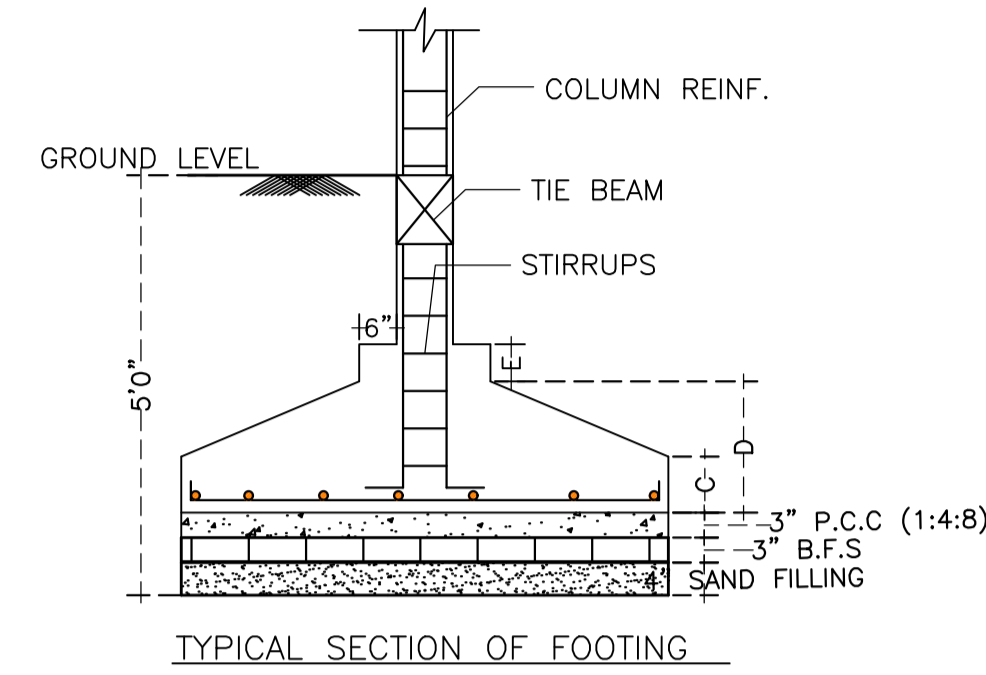
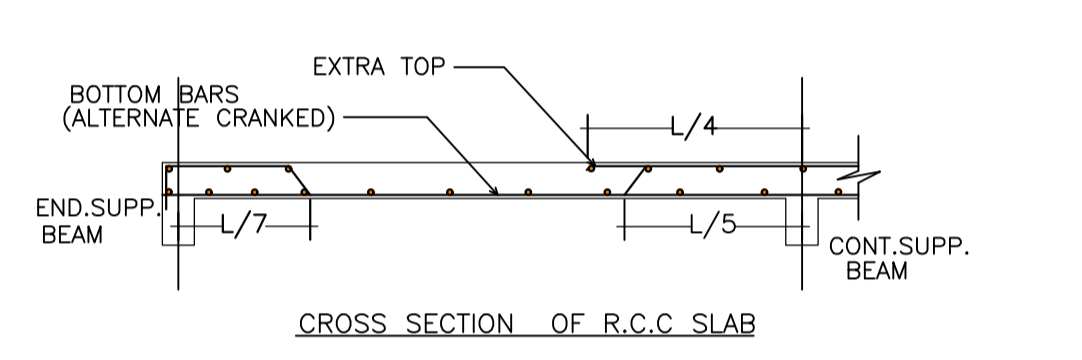
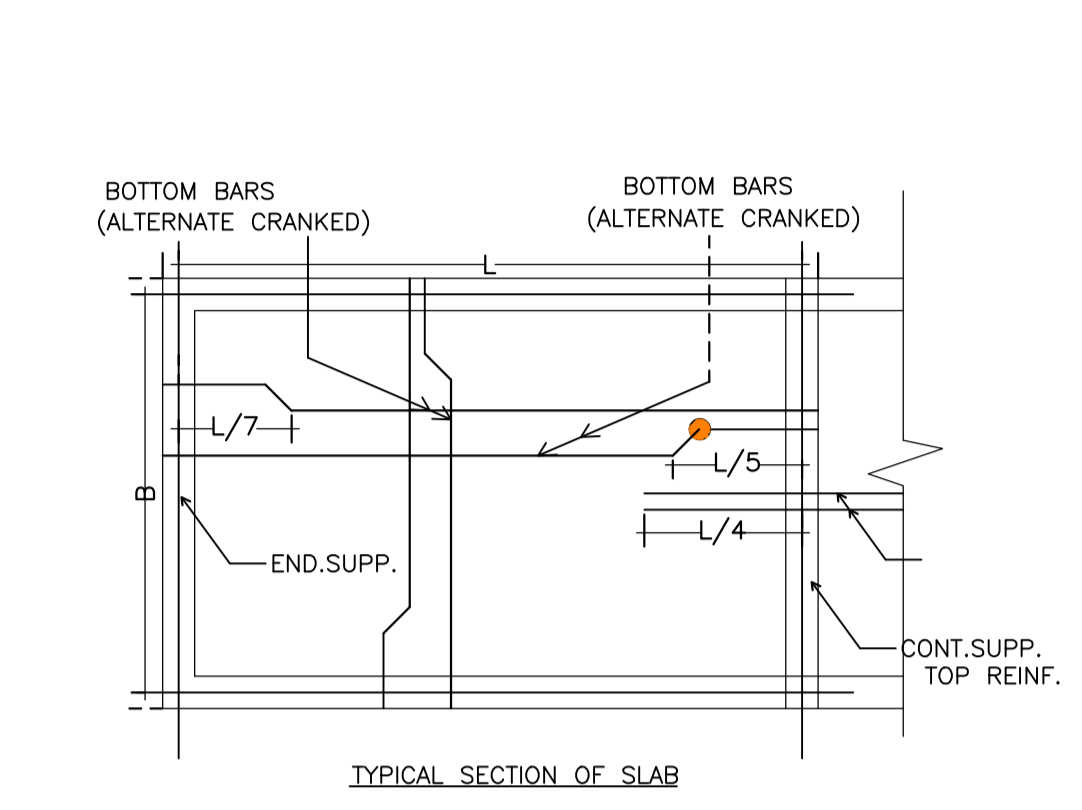

COLUMN SIZE	B	L	CONCRETE MIX	SECTION WITH MAIN STEEL	LINKS
C1	9"	12"	M20	6 - 12 mm. Tor	6 mm. @ 8" c/c
C2	9"	15"	M20	4 - 12 mm. Tor 2 - 16 mm. Tor	
C3	9"	15"	M20	6 - 16 mm. Tor	

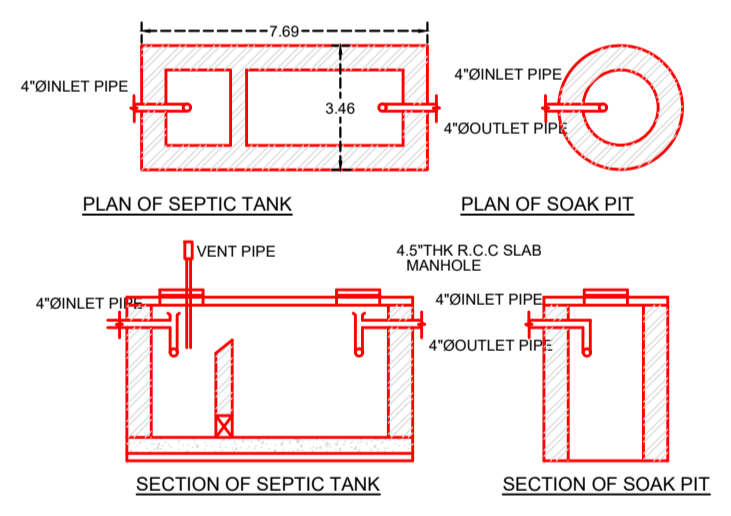
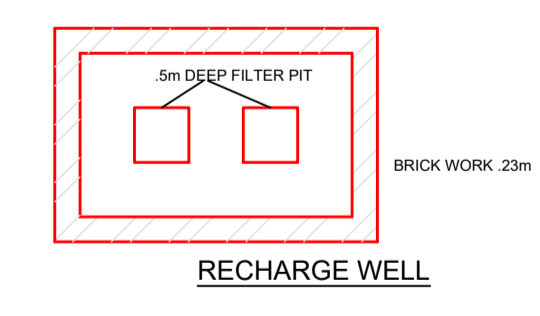
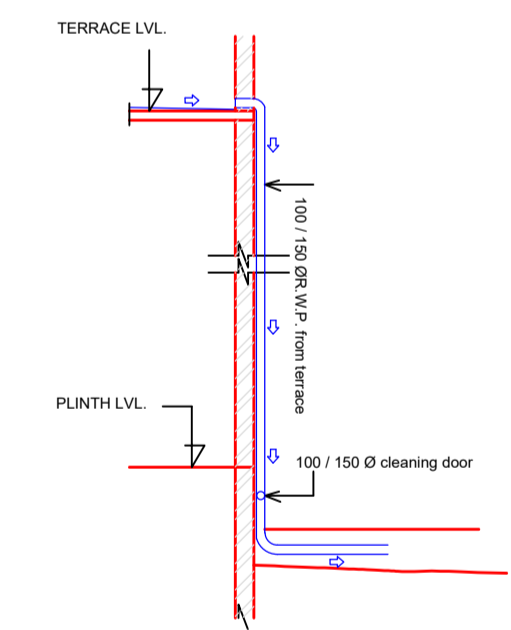
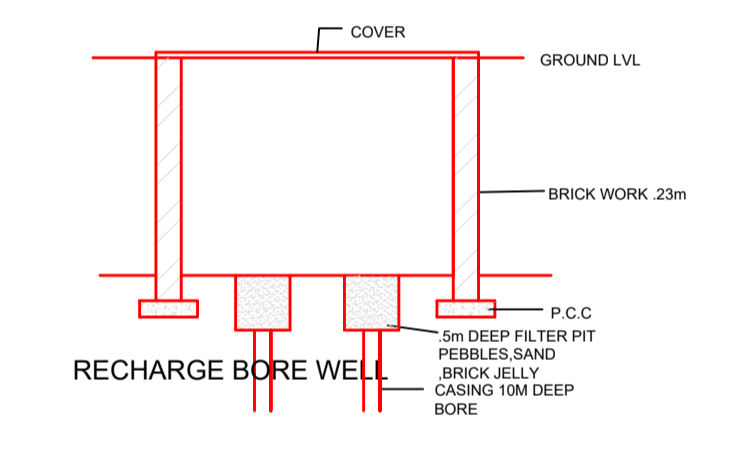
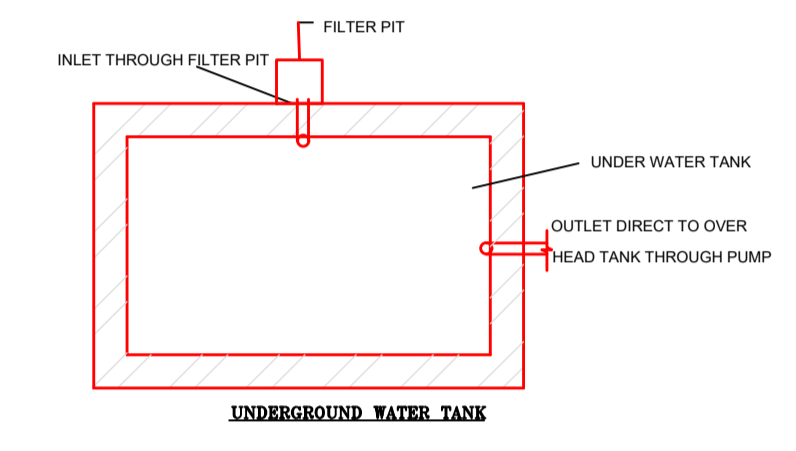
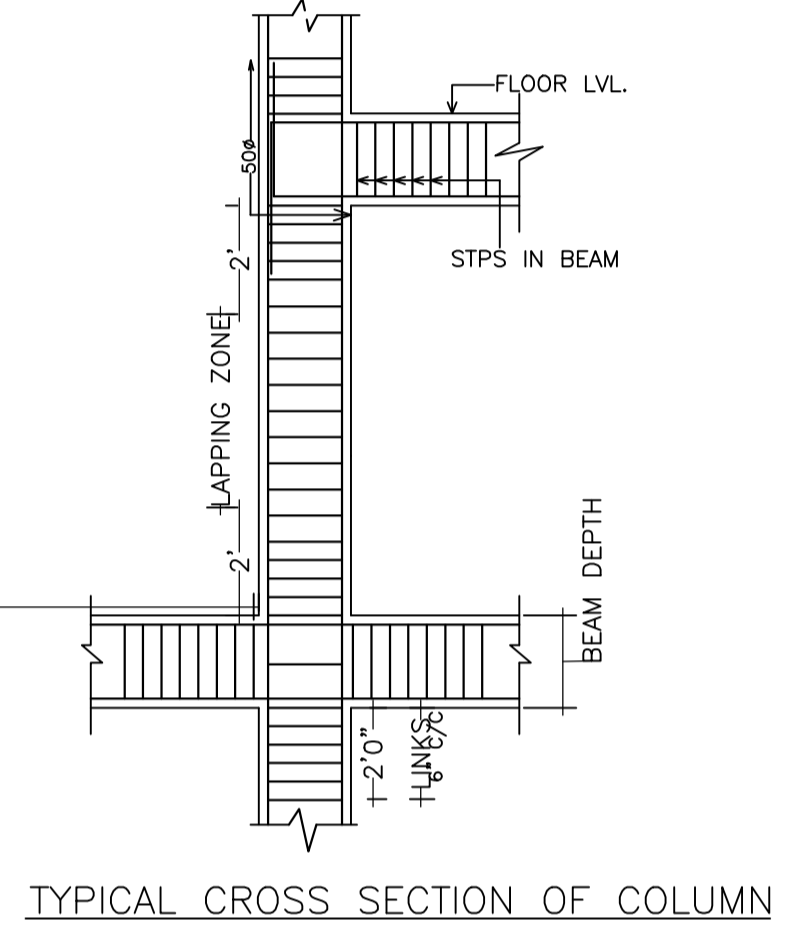

UnitBUA Table for Building :204 (MUKESH)

FLOOR	Name	UnitBUA Type	UnitBUA Area	Carpet Area	No. of Rooms	No. of Tenement
FIRST FLOOR PLAN	SPLIT 1	FLAT	0.00	0.00	6	0
GROUND FLOOR PLAN	SPLIT 1	FLAT	84.30	83.49	2	1
Total	-	-	84.30	83.49	8	1

SCHEDULE OF DOOR:

BUILDING NAME	NAME	LENGTH	HEIGHT	NOS
204 (MUKESH)	D2	0.75	2.10	01
204 (MUKESH)	D1	0.90	2.10	06
204 (MUKESH)	D	1.20	2.10	02

SCHEDULE OF WINDOW/VENTILATION:

BUILDING NAME	NAME	LENGTH	HEIGHT	NOS
204 (MUKESH)	V	0.60	0.90	05
204 (MUKESH)	W2	1.20	1.50	01
204 (MUKESH)	W3	1.20	1.50	03
204 (MUKESH)	D1	1.50	1.20	02

Building :204 (MUKESH)

Floor Name	Total Built Up Area (Sq.mt.)	Deductions (Area in Sq.mt.) Parking	Proposed FAR Area (Sq.mt.) Resi.	Total FAR Area (Sq.mt.)	Total Consumed Additional FAR Area (Sq.mt.)	Tnmt (No.)
Ground Floor	64.74	32.98	31.76	31.76	31.76	01
First Floor	64.75	0.00	64.75	64.75	64.75	00
Terrace Floor	0.00	0.00	0.00	0.00	0.00	00
Total	129.49	32.98	96.51	96.51	96.51	01
Total Number of Same Buildings	1					
Total	129.49	32.98	96.51	96.51	96.51	01

LTP NAME AND SIGNATURE	STRUCTURAL ENG'S NAME AND SIGNATURE	BUILDER NAME AND SIGNATURE	DIGITAL SIGNATURE
Abhishek Tewari AMC/ARC/0026/2016			