

Proposal Basic Information

Proposal File No.	AMC/BP/0001/W22/2020
Owner Name	SEEMA CHAKRABORTY
Khata No	222
Plot No	1213
Village Name	ASANGI
Use	Residential
SubUse	Semidetached

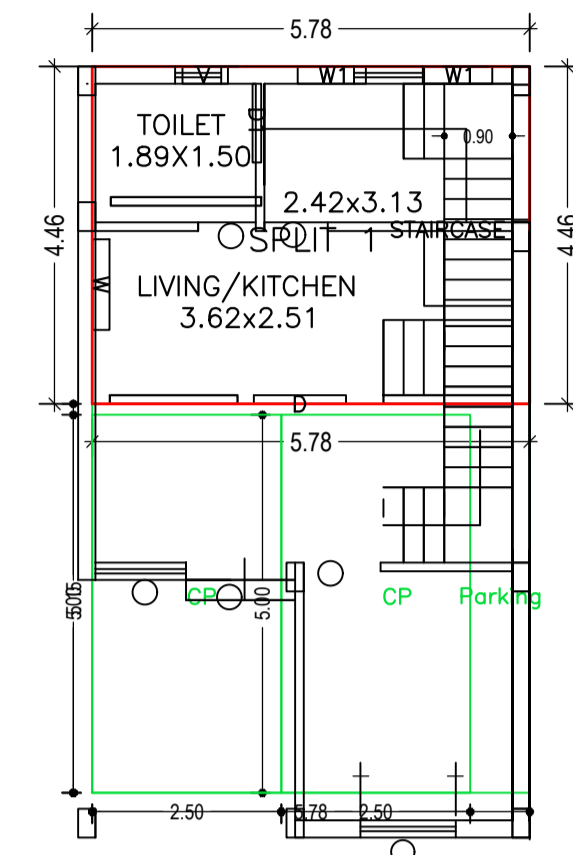

GROUND FLOOR PLAN (Proposed) (SCALE 1:100)

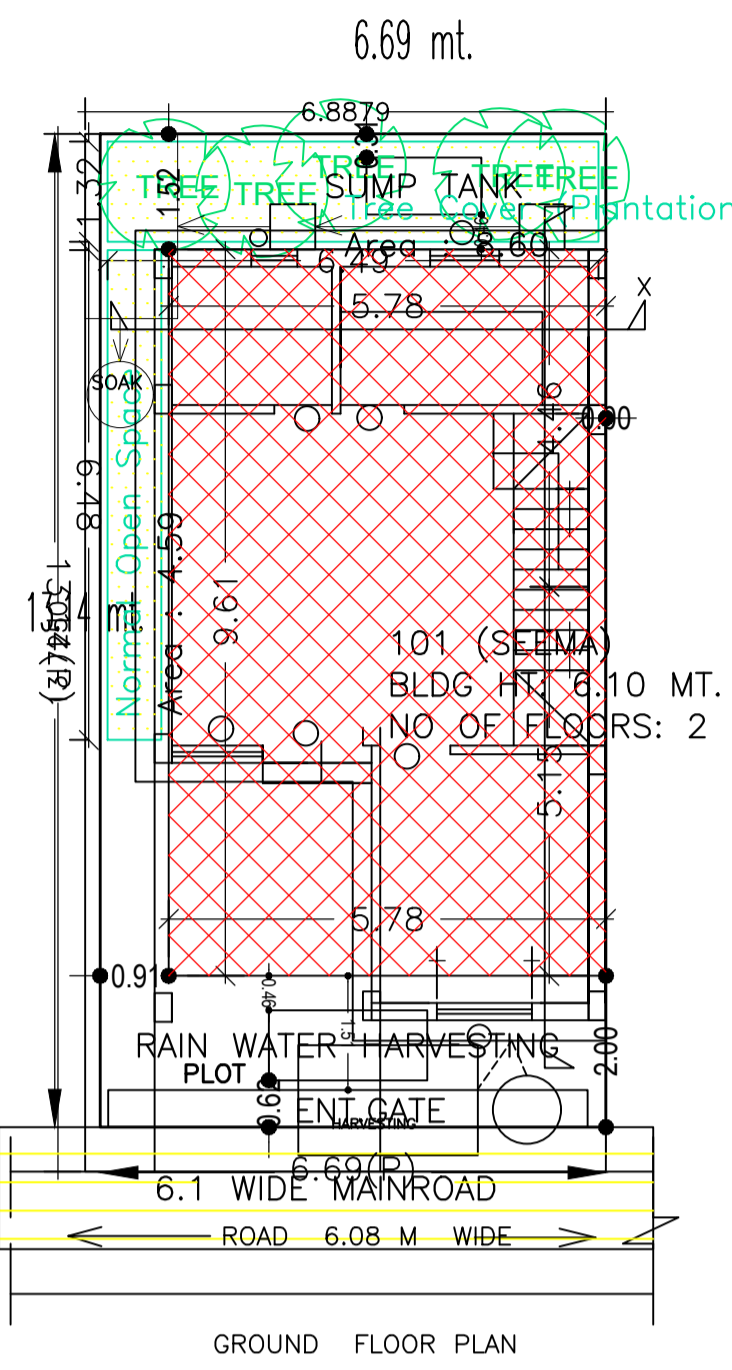
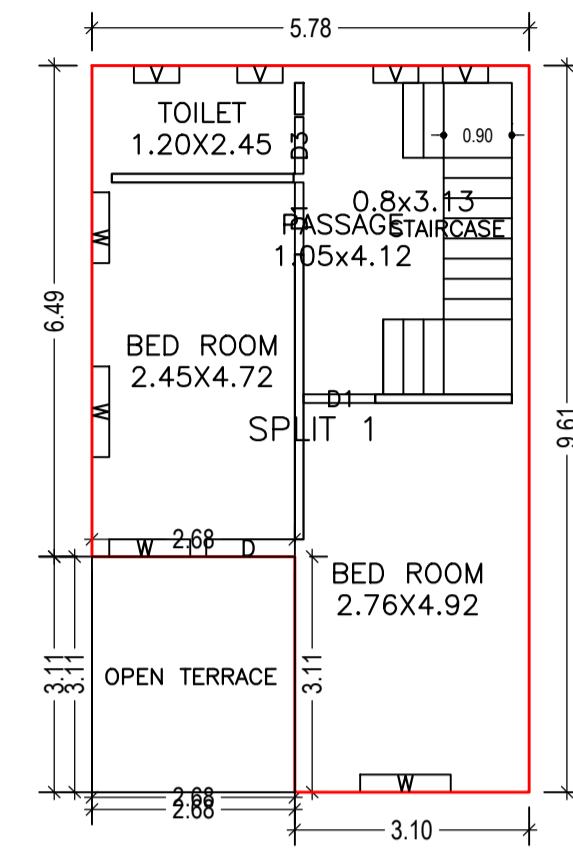

FIRST FLOOR PLAN (Proposed) (SCALE 1:100)

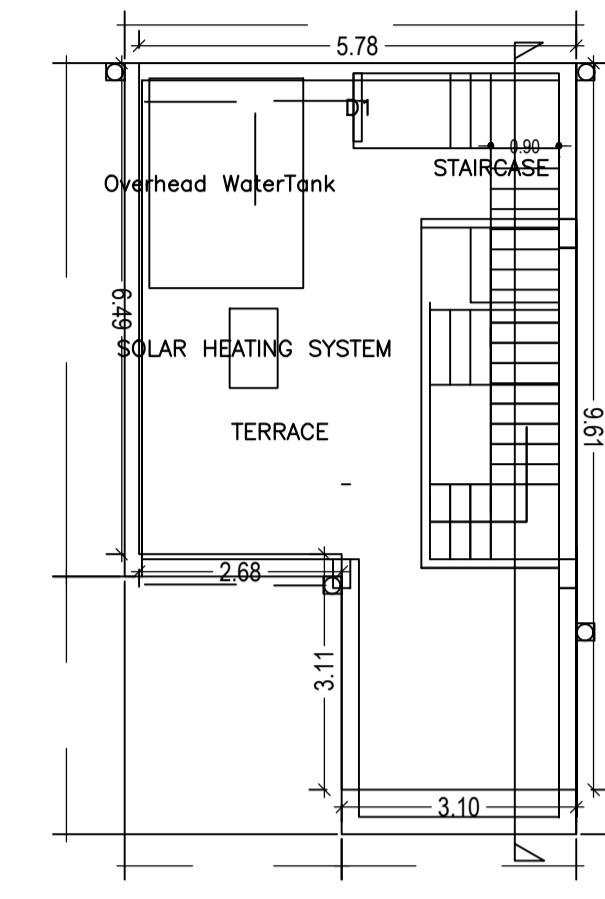

TERRACE FLOOR PLAN (SCALE 1:100)

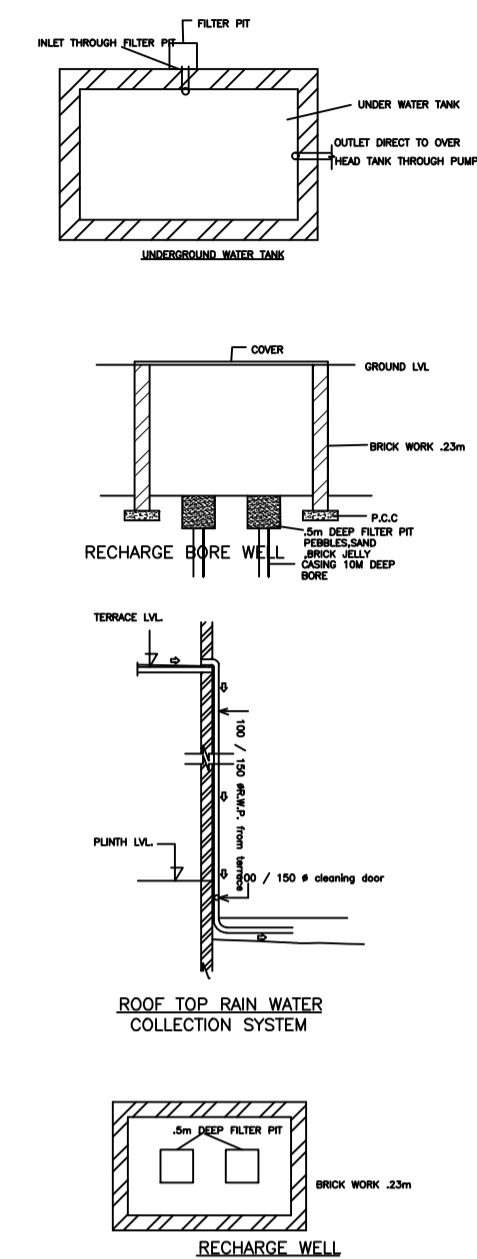

SITE PLAN

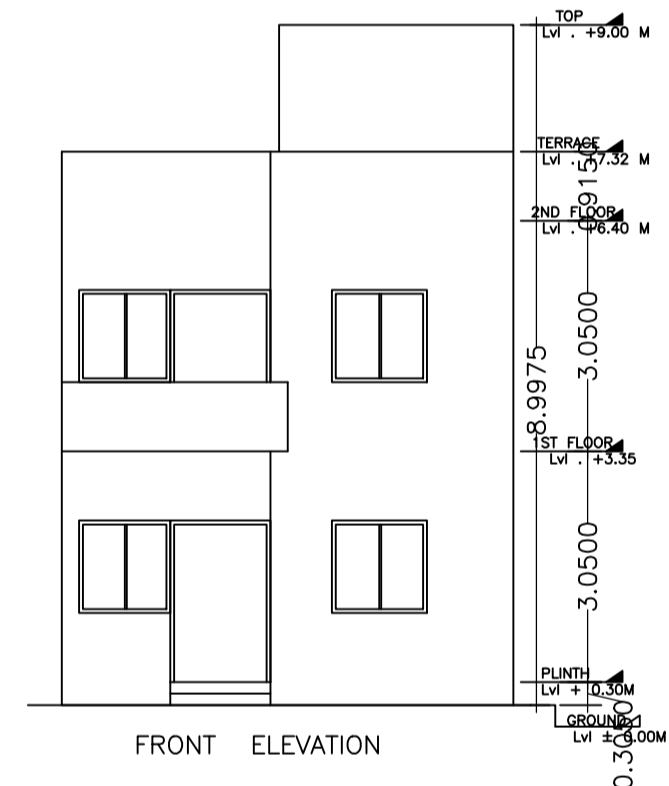

FRONT ELEVATION

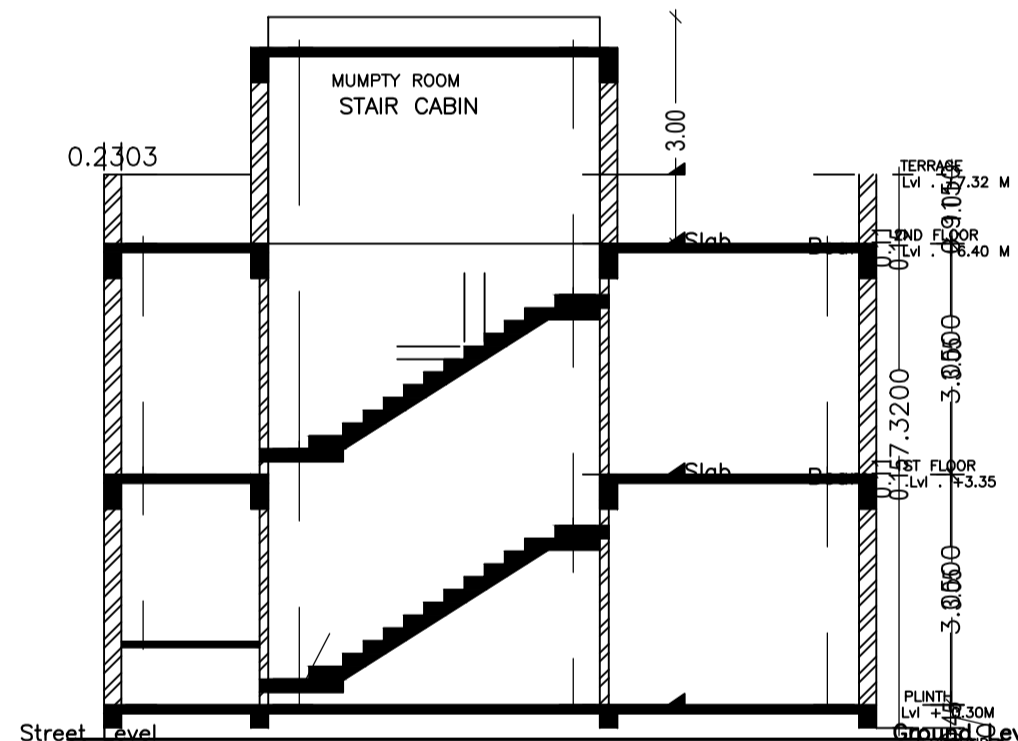

SECTION Y-Y

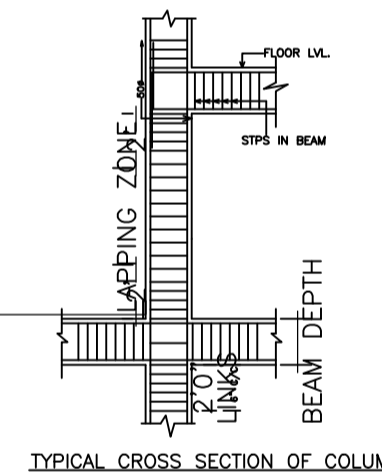
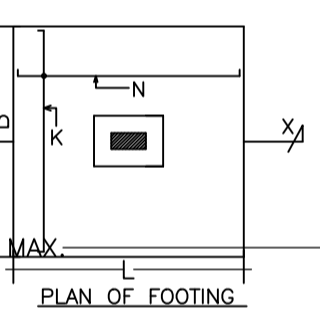
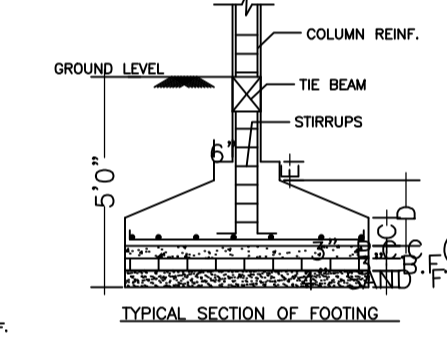
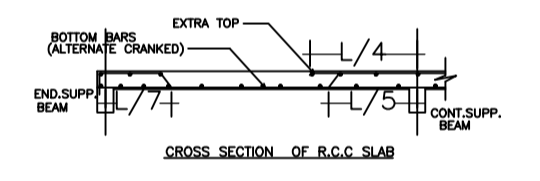
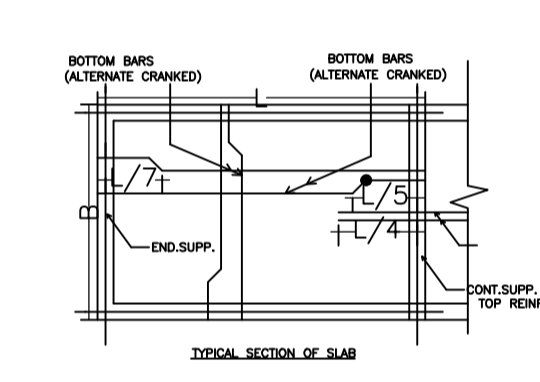

TYPICAL CROSS SECTION OF COLUMN



SIDE ELEVATION

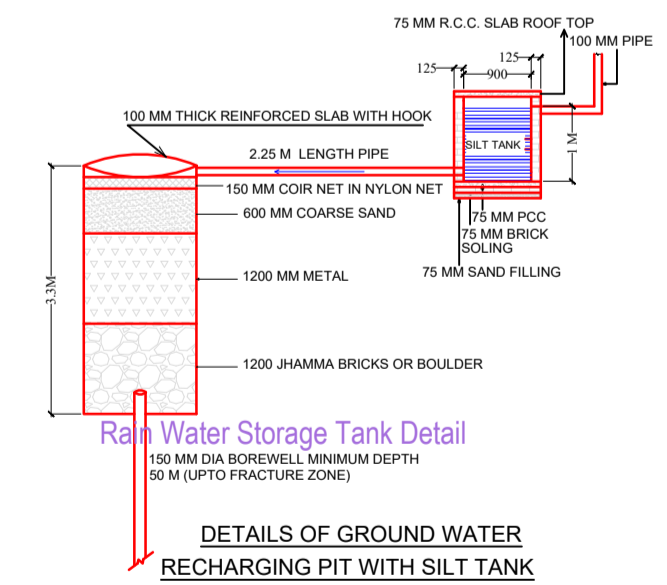
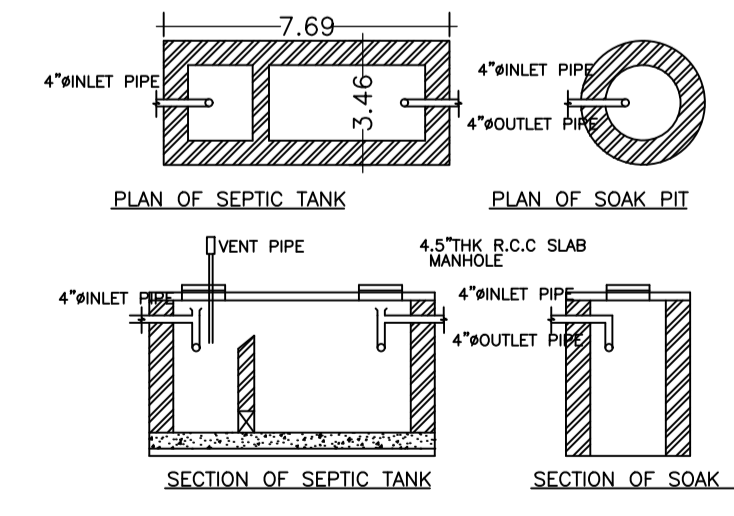

DETAILS OF GROUND WATER RECHARGING PIT WITH SILT TANK

COLOR INDEX

PLOT BOUNDARY	Black
ABUTTING ROAD	Red
PROPOSED CONSTRUCTION	Green
COMMON PLOT	Yellow
ROAD WIDENING AREA	Blue
EXISTING (To be retained)	Light Blue
EXISTING (To be demolished)	Dark Blue

FAR & Tenement Details (Table 4c-1)

Building	No. of Same Bldg	Total Built Up Area (Sq.mt.)	Deductions (Area in Sq.mt.)	Proposed FAR Area (Sq.mt.)	Total FAR Area (Sq.mt.)	Total Consumed Additional FAR Area (Sq.mt.)	Tnmt (No.)
101 (SEEMA)	1	102.79	29.76	73.03	73.03	73.03	01
Grand Total:	1	102.79	29.76	73.03	73.03	73.03	01

Buildingwise Floor FAR Details

Floor Name	Building Name 101 (SEEMA)		Total	
	Proposed Built Up Area (Sq.mt.)	Proposed FAR Area (Sq.mt.)	Total Proposed Built Up Area (Sq.mt.)	Total FAR Area (Sq.mt.)
Ground Floor	55.58	25.82	55.58	25.82
First Floor	47.21	47.21	47.21	47.21
Terrace Floor	0.00	0.00	0.00	0.00
Total:	102.79	73.03	102.79	73.03

UnitBUA Table for Building :101 (SEEMA)

FLOOR	Name	UnitBUA Type	UnitBUA Area	Carpet Area	No. of Rooms	No. of Tenement
GROUND FLOOR	SPLIT 1	FLAT	62.68	61.49	2	1
FIRST FLOOR	SPLIT 1	FLAT	0.00	0.00	4	0
Total:	-	-	62.68	61.49	6	1

Building USE/SUBUSE Details

Building Name	Building Use	Building SubUse	Building Structure
101 (SEEMA)	Residential	Semidetached	Non-Highrise

AREA STATEMENT

ADITYAPUR MUNICIPAL CORPORATION	VERSION NO: 1.0.46	
ADITYAPUR MUNICIPAL CORPORATION	VERSION DATE: 22/06/2020	
PROJECT DETAIL:		
Region: JHARKHAND URBAN LOCAL BODIES	Plot Use: Residential	
District: EAST SINGHBHUM	Plot SubUse: Semidetached	
Authority: ADITYAPUR MUNICIPAL CORPORATION	PlotNearbyReligiousStructure: NA	
Inward No: AMC/BP/0001/W22/2020	Plot/SubPlot No: 1213	
Application Type: General Proposal	North: -	
Project Type: Building Permission	South: Plot No. - DLX-202	
Nature of Development: New	East: -	
Location of Development Area: Old Area	West: Road Width - 6.01	
AREA DETAILS:		
AREA OF PLOT (Minimum)	(A)	87.89
NET AREA OF PLOT (Gross Plot Area - Deduction from Gross Plot area)	(A-Deductions)	87.89
Deduction for Balance Plot Area (from Gross Plot Area)		
Common Plot		13.19
Total		13.19
BALANCE AREA OF PLOT (Net Plot Area - Recreational/Amenity space)	(A-Deductions)	74.70
PLOT AREA FOR COVERAGE (Net Plot Area)	(A-Deductions)	87.89
Plot Area for FAR (Net Plot Area + Road Widening Area)	(A-Deductions)	87.89
COVERAGE CHECK		
Permissible Coverage area (70.00 %)		61.52
Proposed Coverage Area (63.24 %)		55.58
Total Prop. Coverage Area (63.24 %)		55.58
Balance coverage area (6.76 %)		5.94
FAR CHECK		
Perm. FAR Area (2.50)		219.73
Total Perm. FAR area		219.73
Residential FAR		73.03
Proposed FAR Area		73.03
Total Proposed FAR Area		73.03
Consumed FAR (Factor)		0.83
Balance FAR Area		146.70
BUILT UP AREA CHECK		
Total Proposed Built Up Area		102.79
ARCHITECT (Regd)	Abhishek Tewari	
ENGINEER (Regd)		
SUPERVISOR (Regd)		
OWNER (Regd)	SEEMA CHAKRABORTY	
DEVELOPMENT AUTHORITY		LOCAL BODY

Building :101 (SEEMA)

Floor Name	Total Built Up Area (Sq.mt.)	Deductions (Area in Sq.mt.)	Proposed FAR Area (Sq.mt.)	Total FAR Area (Sq.mt.)	Total Consumed Additional FAR Area (Sq.mt.)	Tnmt (No.)
Ground Floor	55.58	29.76	25.82	25.82	25.82	01
First Floor	47.21	0.00	47.21	47.21	47.21	00
Terrace Floor	0.00	0.00	0.00	0.00	0.00	00
Total:	102.79	29.76	73.03	73.03	73.03	01
Total Number of Same Buildings	1					
Total:	102.79	29.76	73.03	73.03	73.03	01

SCHEDULE OF DOOR:

BUILDING NAME	NAME	LENGTH	HEIGHT	NOS
101 (SEEMA)	D3	0.75	2.13	01
101 (SEEMA)	D1	0.95	2.13	02
101 (SEEMA)	D	1.04	2.13	01
101 (SEEMA)	D	1.17	2.13	01
101 (SEEMA)	D	1.22	2.13	01

SCHEDULE OF WINDOW/VENTILATION:

BUILDING NAME	NAME	LENGTH	HEIGHT	NOS
101 (SEEMA)	V	0.60	0.90	05
101 (SEEMA)	W1	0.90	1.20	02
101 (SEEMA)	W	0.93	1.50	01
101 (SEEMA)	W	1.07	1.50	01
101 (SEEMA)	W	1.20	1.50	03

LTP NAME AND SIGNATURE

Abhishek Tewari AMC/ARC/0026/2016	STRUCTURAL ENG'S NAME AND SIGNATURE	BUILDER NAME AND SIGNATURE	DIGITAL SIGNATURE
--------------------------------------	-------------------------------------	----------------------------	-------------------