

Proposal Basic Information	
Proposal File No.	AMC/BP/0039/W27/2020
Owner Name	SMT ANJU
Khata No	LR/15
Plot No	LR/15
Village Name	DINDLI
Use	Residential
SubUse	Bungalow/ Dwelling / Non Apartment

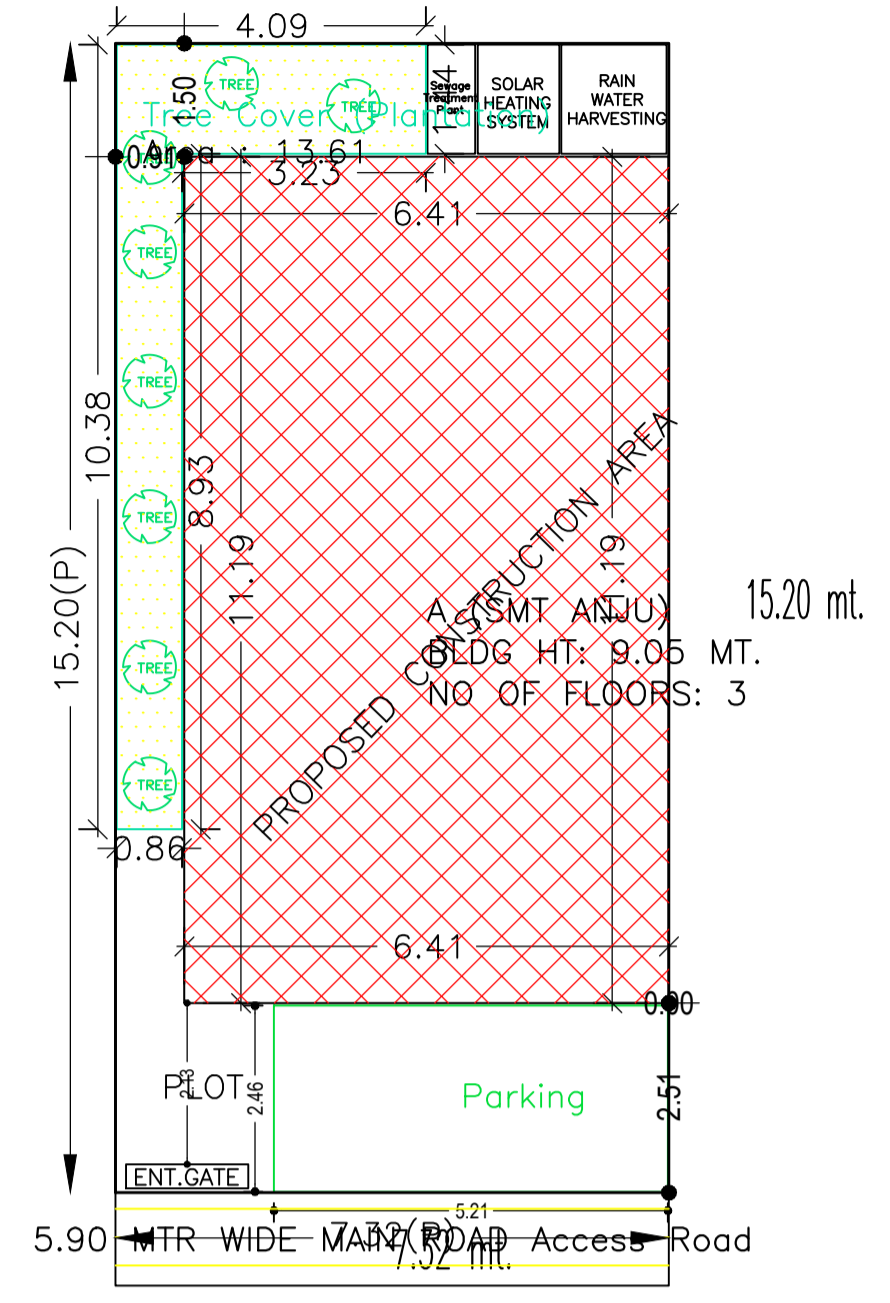

SITE PLAN

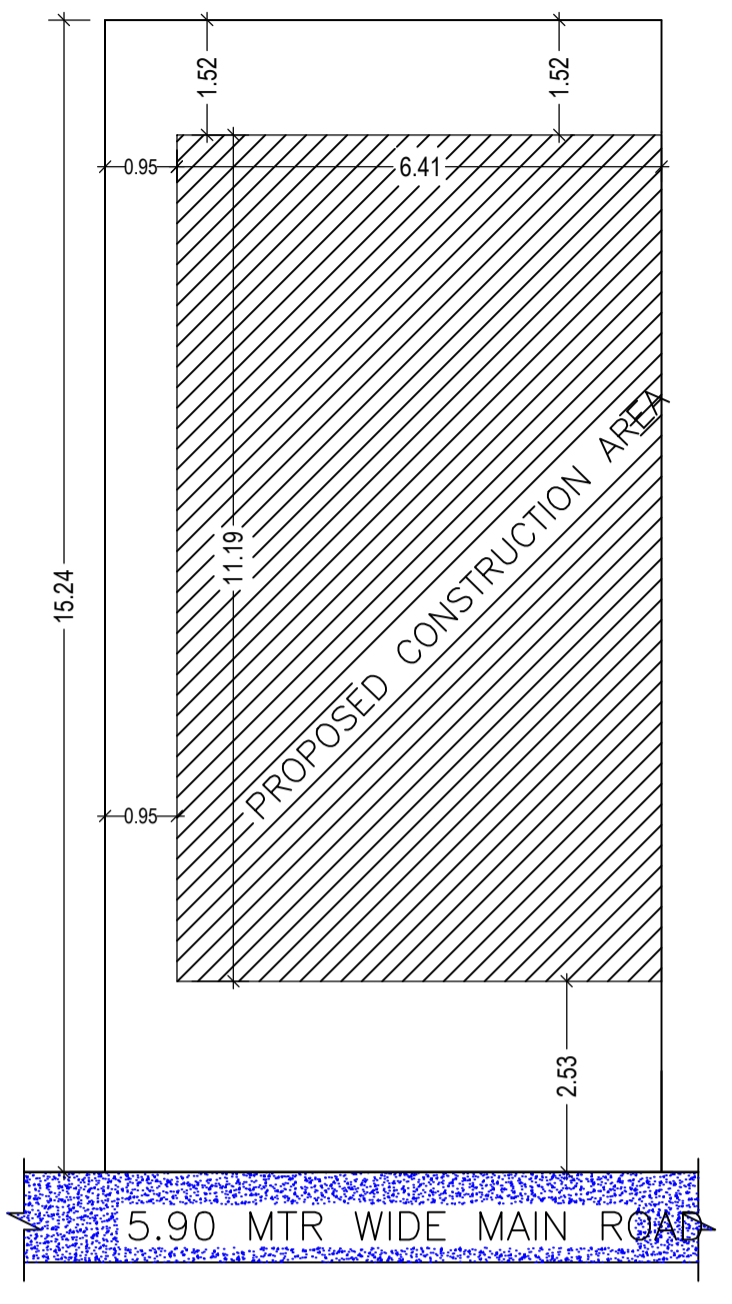

SITE PLAN
SCALE-1:100

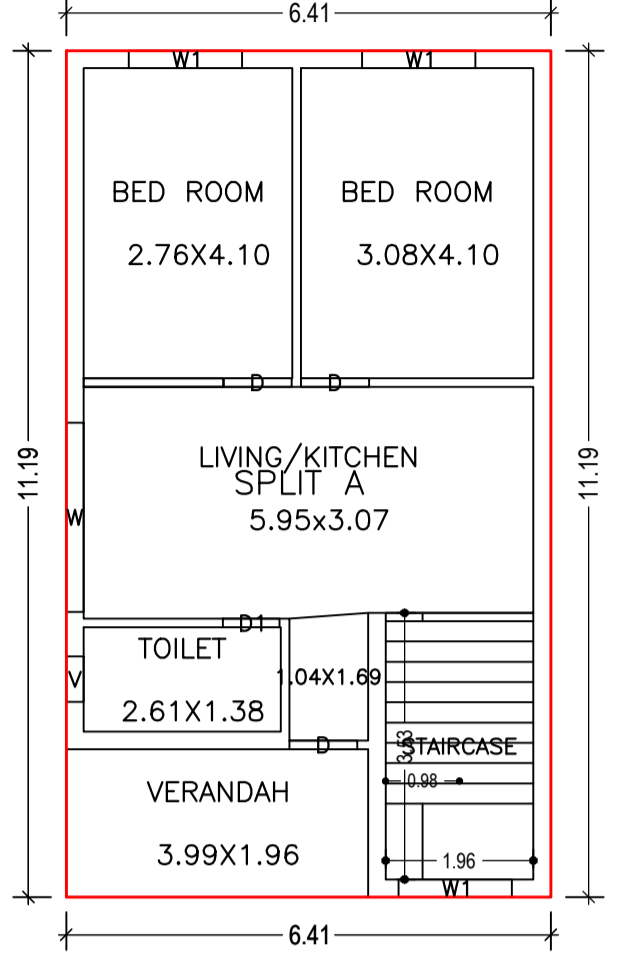

GROUND FLOOR PLAN
(Proposed)
SCALE 1:100

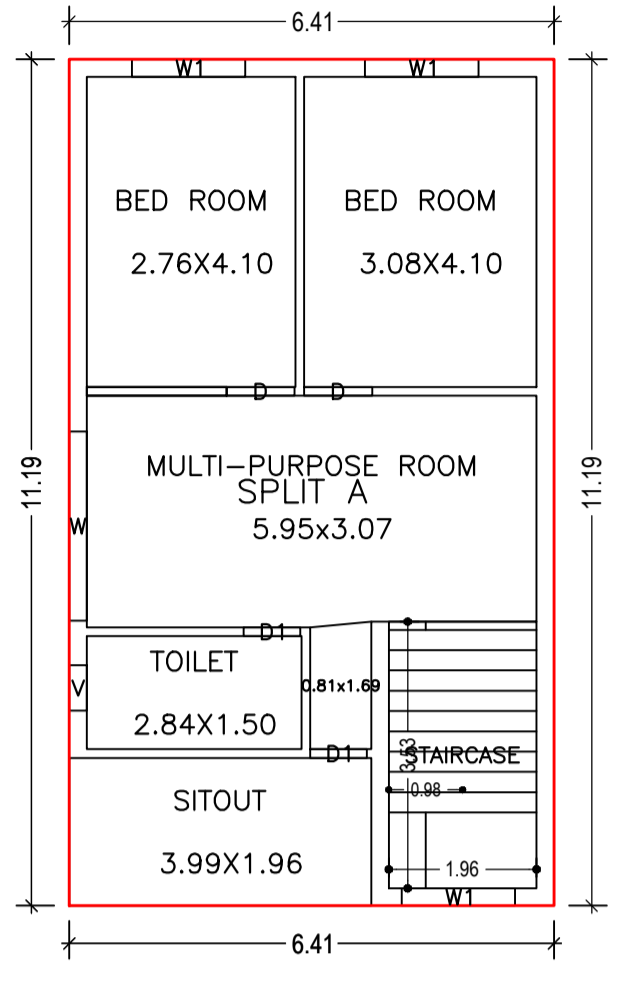

FIRST FLOOR PLAN
(Proposed)
SCALE 1:100

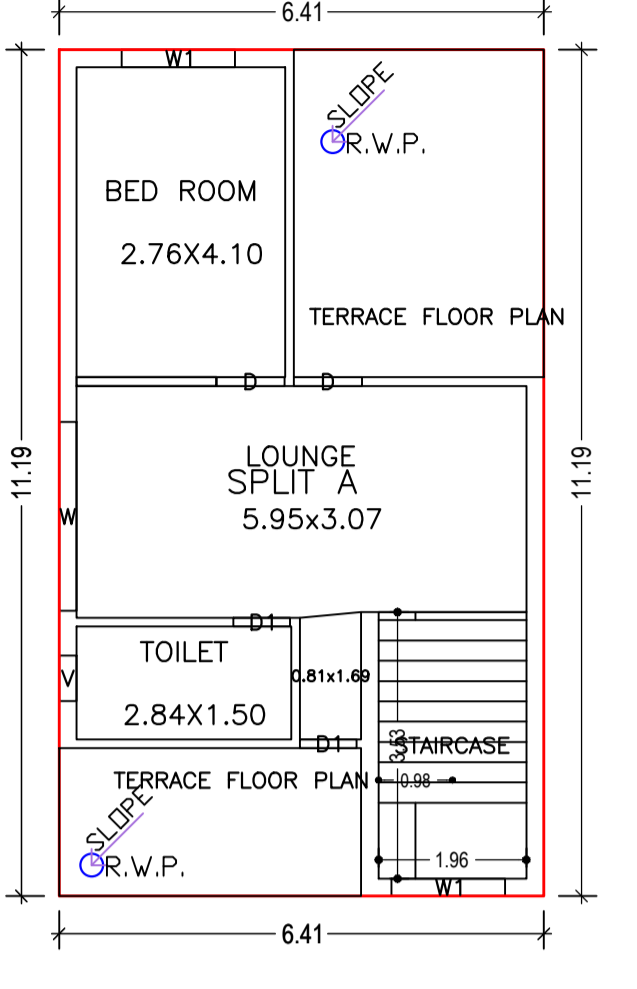

SECOND FLOOR PLAN
(Proposed)
SCALE 1:100

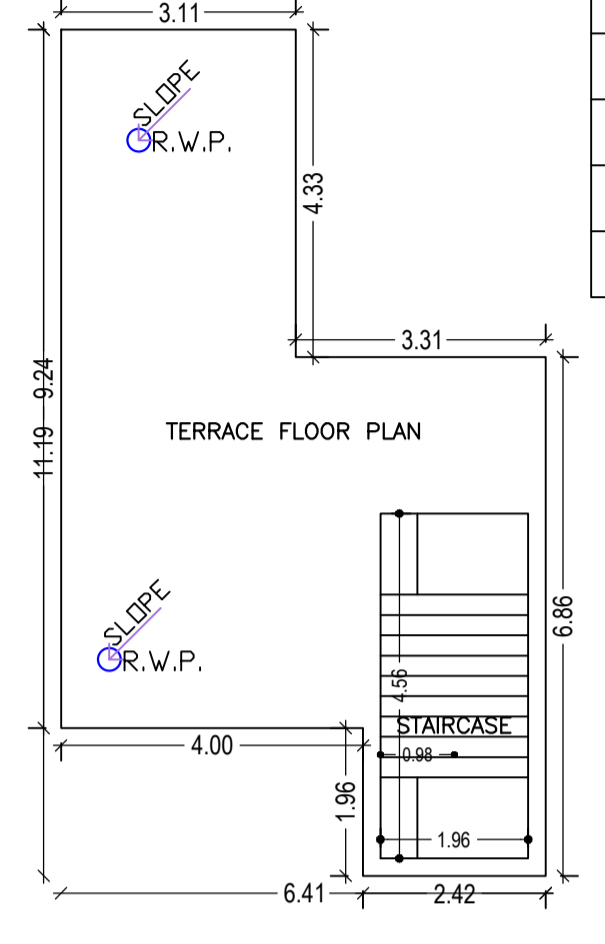

TERRACE FLOOR PLAN
SCALE 1:100

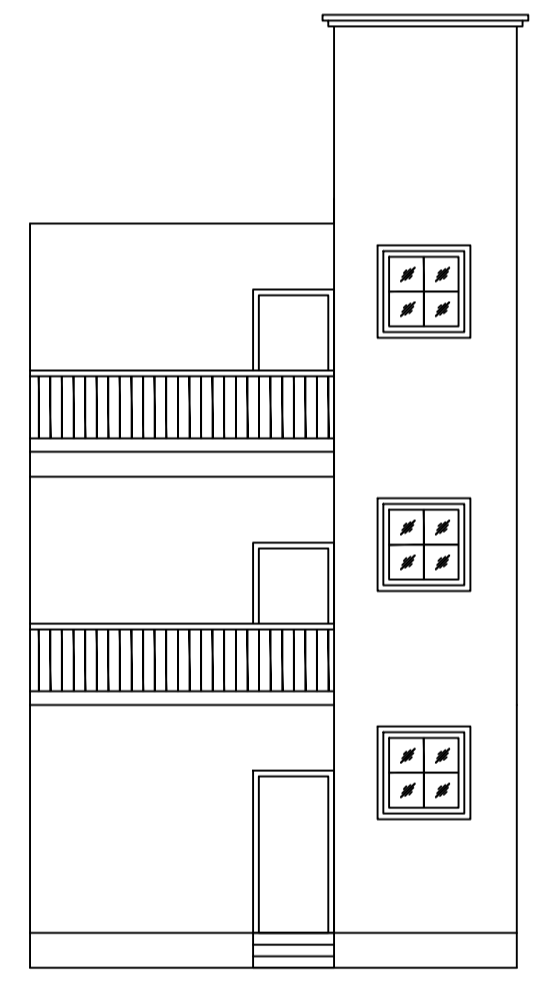

FRONT ELEVATION
SCALE-1:100

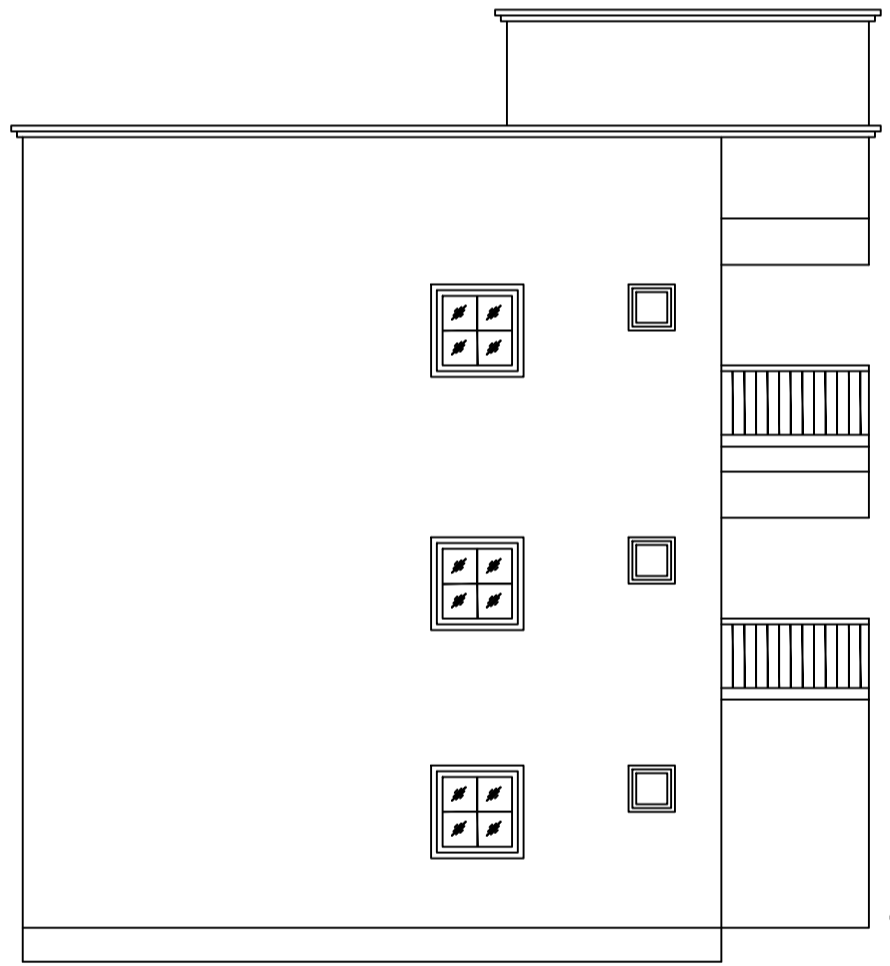

SIDE ELEVATION
SCALE-1:100

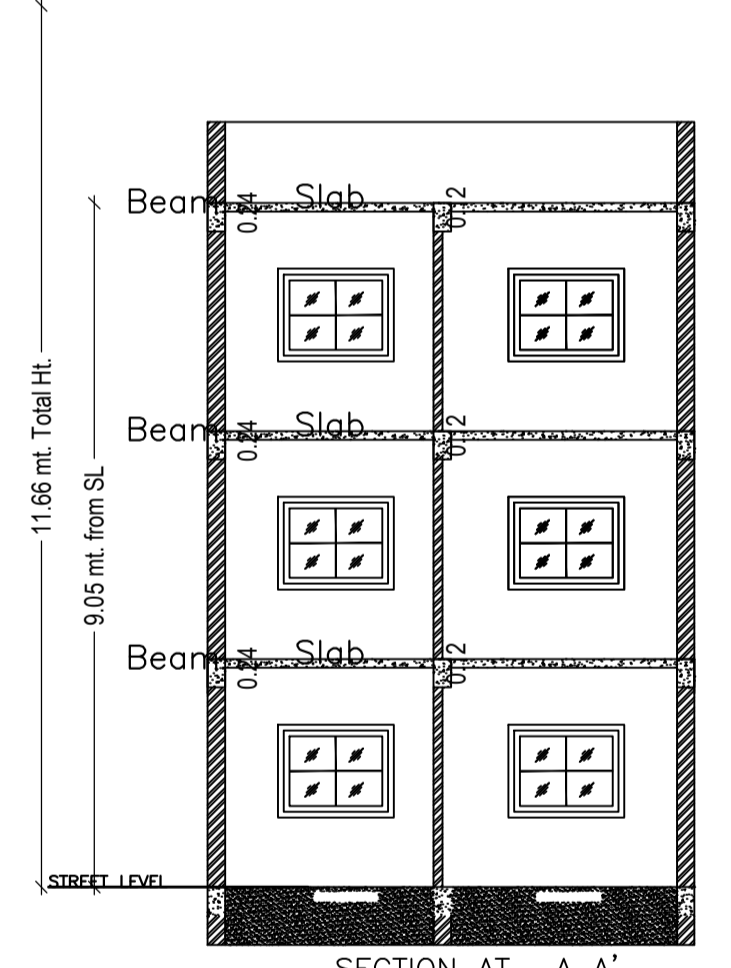

SECTION AT -A A'
SCALE-1:100

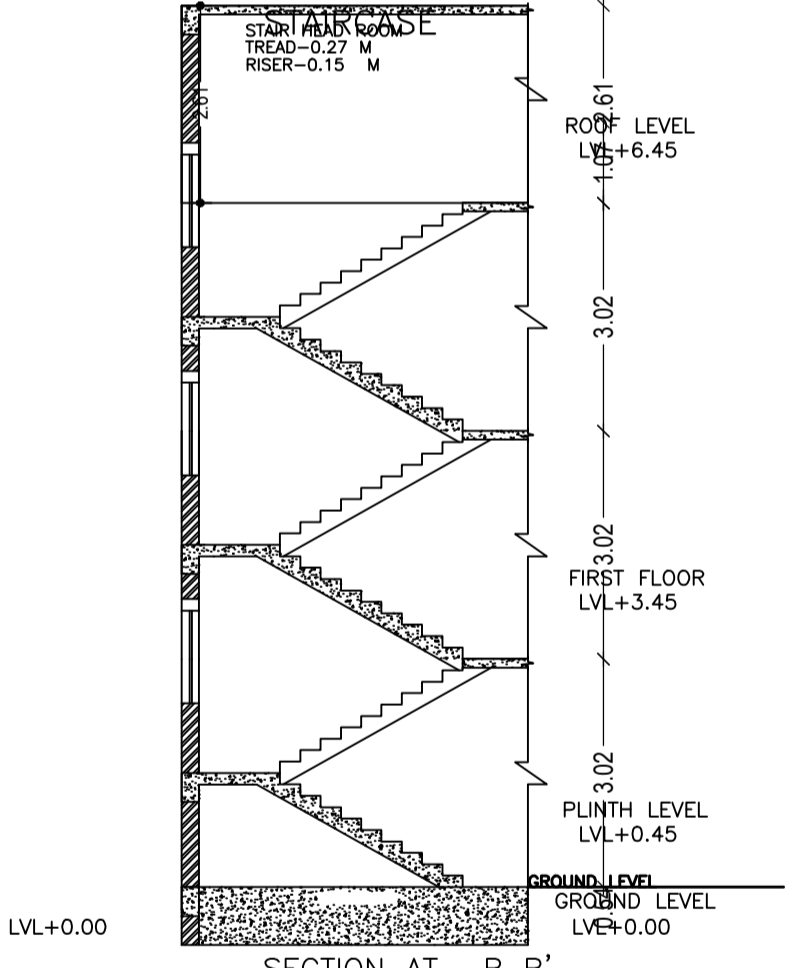

SECTION AT -B B'
SCALE-1:100

FAR & Tenement Details (Table 4c-1)

Building	No. of Same Bldg	Total Built Up Area (Sq.mt)	Proposed FAR Area (Sq.mt) Resi.	Total FAR Area (Sq.mt)	Total Consumed Additional FAR Area (Sq.mt)	Trmt (No.)
A (SMT ANJU)	1	193.12	193.12	193.12	193.12	01
Grand Total:	1	193.12	193.12	193.12	193.12	01

AREA STATEMENT		VERSION NO. : 1.0.53
ADITYAPUR MUNICIPAL CORPORATION		VERSION DATE: 16/10/2020
PROJECT DETAIL:		
Region : JHARKHAND URBAN LOCAL BODIES	Plot Use: Residential	
District : EAST SINGBHUM	Plot SubUse: Bungalow/ Dwelling / Non Apartment	
Authority: ADITYAPUR MUNICIPAL CORPORATION	PlotNearby/ReligiousStructure: NA	
Inward No: AMC/BP/0039/W27/2020	Plot/SubPlot No: LR/15	
Application Type: General Proposal	North: Plot No. - C.I.G ROW HOUSE NO- 6	
Project Type: Building Permission	South: Road Width - 6.10 MTR WIDE MAIN ROAD	
Nature of Development: New	East: Plot No. - L.I.G ROW HOUSE NO-16	
Location of Development Area: Old Area	West: Plot No. - L.I.G ROW HOUSE NO-14	
AREA DETAILS:		
AREA OF PLOT (Minimum)	(A)	111.26
NET AREA OF PLOT(Gross Plot Area - Deduction from Gross Plot area)	(A-Deductions)	111.26
Deduction for Balance Plot Area(from Gross Plot Area)		
Common Plot		13.61
Total		13.61
BALANCE AREA OF PLOT(Net Plot Area - Recreational/Amenity space)	(A-Deductions)	97.66
PLOT AREA FOR COVERAGE(Net Plot Area)	(A-Deductions)	111.26
Plot Area for FAR (Net Plot Area + RoadWidening Area)	(A-Deductions)	111.26
COVERAGE CHECK		
Permissible Coverage area (70.00 %)		77.88
Proposed Coverage Area (64.49 %)		71.75
Total Prop. Coverage Area (64.49 %)		71.75
Balance coverage area (5.51 %)		6.13
FAR CHECK		
Perm. FAR Area (1.80)		200.27
Total Perm. FAR area		200.27
Residential FAR		193.12
Proposed FAR Area		193.12
Total Proposed FAR Area		193.12
Consumed FAR (Factor)		1.74
Balance FAR Area		7.15
BUILT UP AREA CHECK		
Total Proposed BuiltUp Area		193.12
ARCHITECT (Regd)	Anoop Kumar	
ENGINEER (Regd)		
SUPERVISOR (Regd)		
OWNER (Regd)	SMT ANJU	
DEVELOPMENT AUTHORITY		LOCAL BODY

UnitBUA Table for Building :A (SMT ANJU)

FLOOR	Name	UnitBUA Type	UnitBUA Area	Carpet Area	No. of Rooms	No. of Tenement
FIRST FLOOR PLAN	SPLIT A	FLAT	0.00	0.00	5	0
SECOND FLOOR PLAN	SPLIT A	FLAT	0.00	0.00	3	0
GROUND FLOOR PLAN	SPLIT A	FLAT	150.73	150.09	5	1
Total	-	-	150.73	150.09	13	1

COLOR INDEX	
PLOT BOUNDARY	
ABUTTING ROAD	
PROPOSED CONSTRUCTION	
COMMON PLOT	
ROAD WIDENING AREA	
EXISTING (To be retained)	
EXISTING (To be demolished)	

LTP NAME AND SIGNATURE	STRUCTURAL ENG'S NAME AND SIGNATURE	BUILDER NAME AND SIGNATURE	DIGITAL SIGNATURE
Anoop Kumar AMC/ENG/0024/2016			

Proposal Basic Information	
Proposal File No.	AMC/BP/0039/W27/2020
Owner Name	SMT ANJU
Khata No	LR/15
Plot No	LR/15
Village Name	DINDLI
Use	Residential
SubUse	Bungalow/ Dwelling / Non Apartment

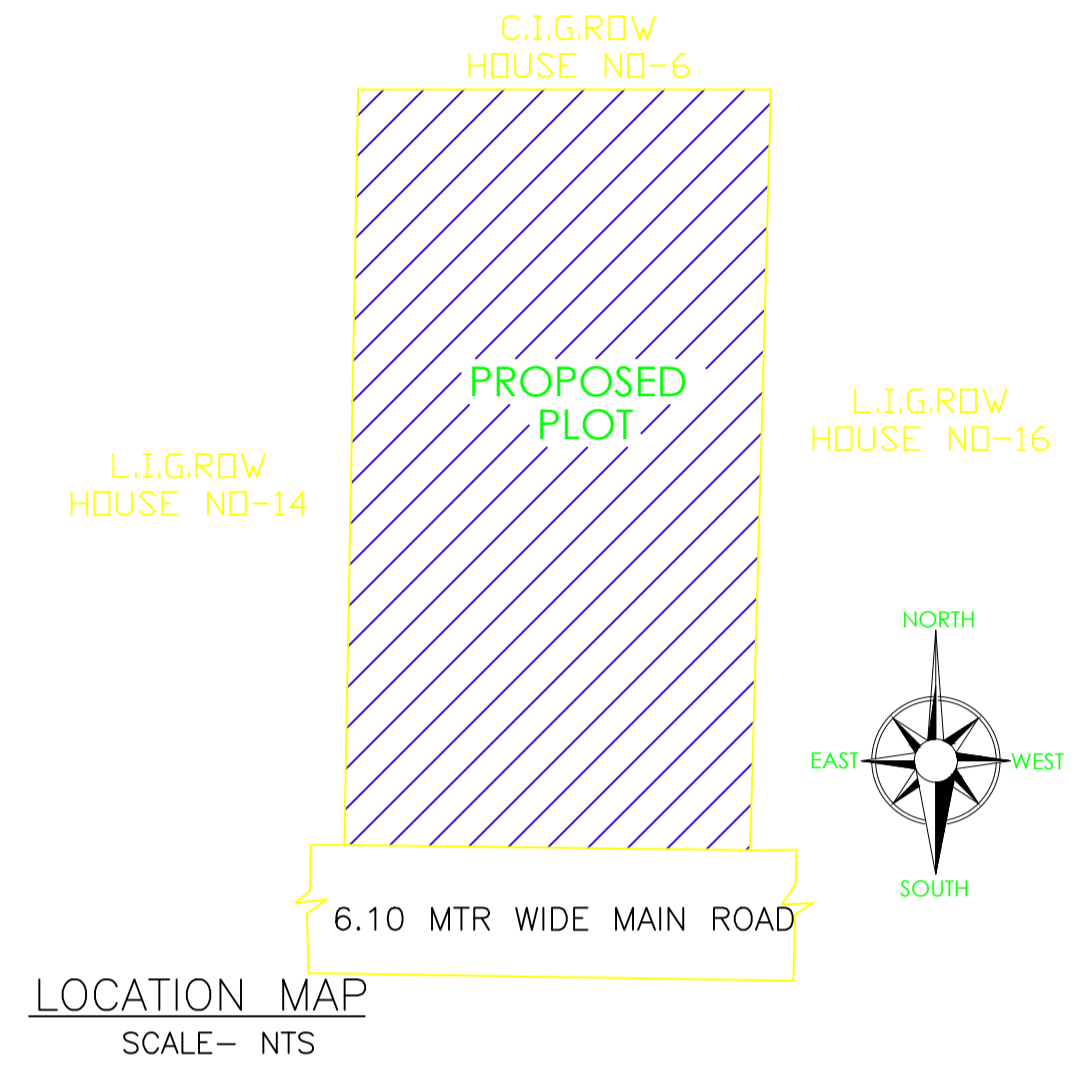

LOCATION MAP
SCALE- NTS

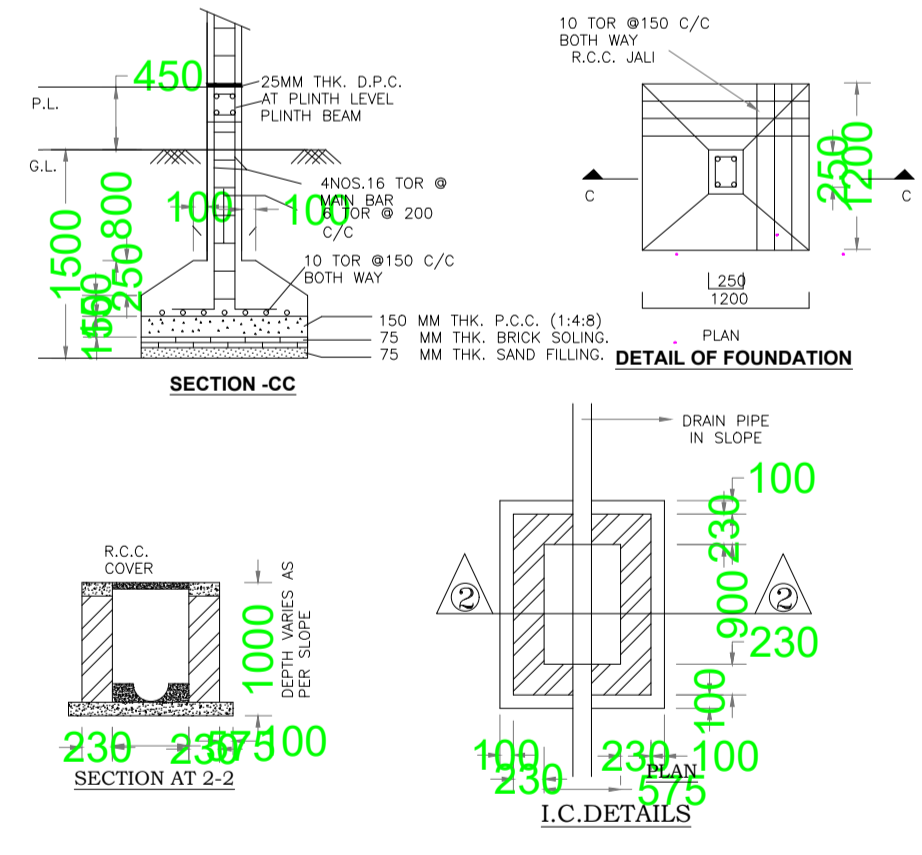
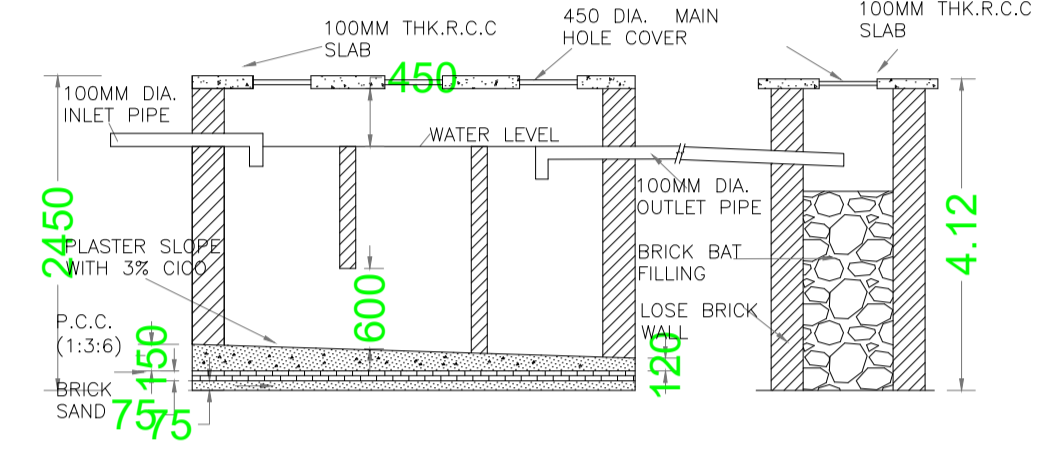
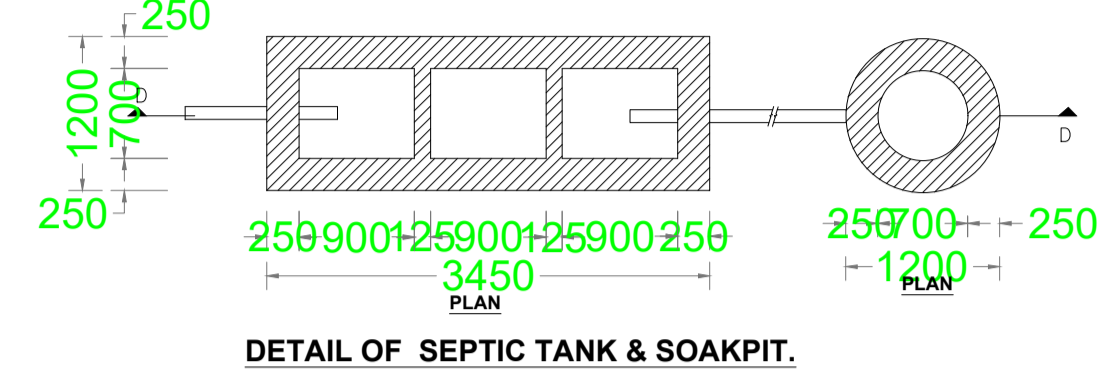
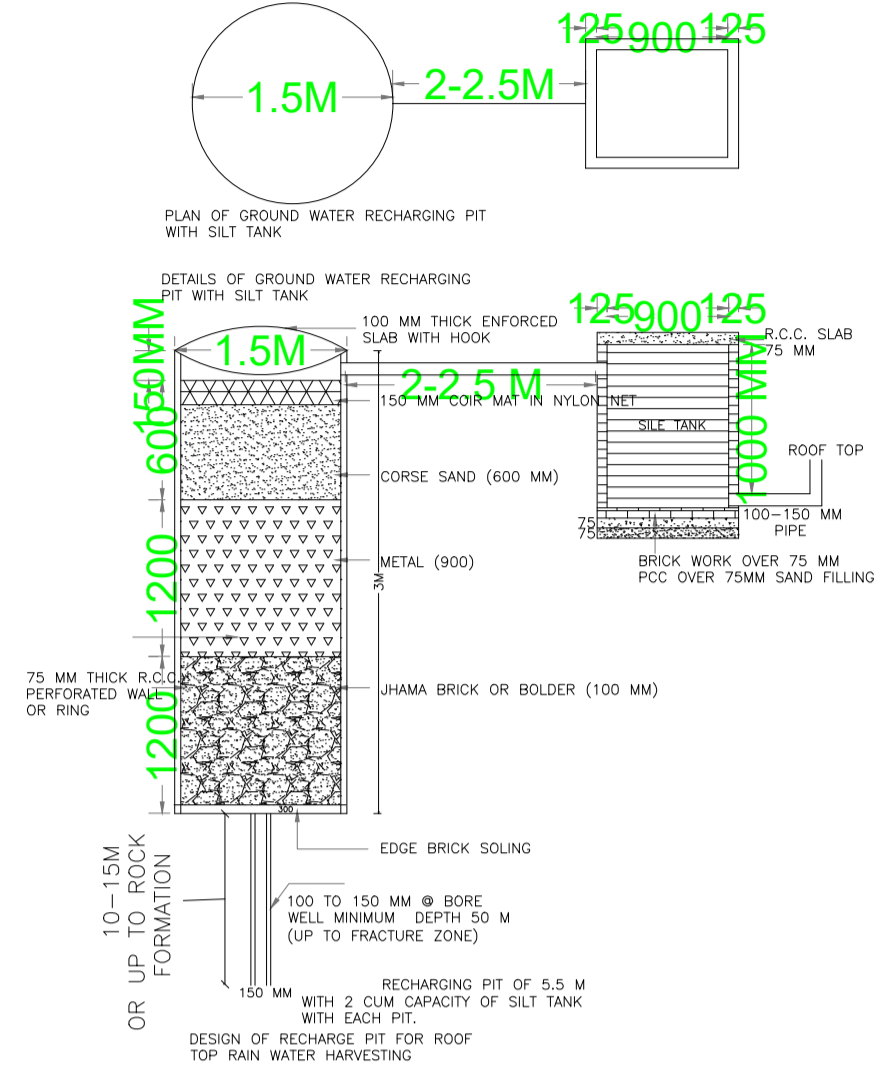

Building :A (SMT ANJU)

Floor Name	Total Built Up Area (Sq.mt.)	Proposed FAR Area (Sq.mt.) Resi.	Total FAR Area (Sq.mt.)	Total Consumed Additional FAR Area (Sq.mt.)	Tnmt (No.)
Ground Floor	71.75	71.75	71.75	71.75	01
First Floor	71.75	71.75	71.75	71.75	00
Second Floor	49.62	49.62	49.62	49.62	00
Terrace Floor	0.00	0.00	0.00	0.00	00
Total :	193.12	193.12	193.12	193.12	01
Total Number of Same Buildings :	1				
Total :	193.12	193.12	193.12	193.12	01

SCHEDULE OF DOOR:

BUILDING NAME	NAME	LENGTH	HEIGHT	NOS
A (SMT ANJU)	D1	0.75	2.13	05
A (SMT ANJU)	D	0.90	2.13	07

SCHEDULE OF WINDOW/VENTILATION:

BUILDING NAME	NAME	LENGTH	HEIGHT	NOS
A (SMT ANJU)	V	0.60	2.70	03
A (SMT ANJU)	W1	1.50	2.70	08
A (SMT ANJU)	W	2.50	2.70	03

Buildingwise Floor FAR Details

Floor Name	Building Name A (SMT ANJU)		Total	
	Proposed Built Up Area (Sq.mt.)	Proposed FAR Area (Sq.mt.)	Total Proposed Built Up Area (Sq.mt.)	Total FAR Area (Sq.mt.)
Ground Floor	71.75	71.75	71.75	71.75
First Floor	71.75	71.75	71.75	71.75
Second Floor	49.62	49.62	49.62	49.62
Terrace Floor	0.00	0.00	0.00	0.00
Total :	193.12	193.12	193.12	193.12

Building USE/SUBUSE Details

Building Name	Building Use	Building SubUse	Building Structure
A (SMT ANJU)	Residential	Bungalow/ Dwelling / Non Apartment	Non-Highrise

LTP NAME AND SIGNATURE	STRUCTURAL ENG'S NAME AND SIGNATURE	BUILDER NAME AND SIGNATURE	DIGITAL SIGNATURE
Anoop Kumar AMC/ENG/0024/2016			