

Proposal Basic Information	
Proposal File No.	AMC/BP/0069/W30/2020
Owner Name	PRAMOD KUMAR AND SUNITA ROY
Khata No	18,178, SUB PLOT 17(A)
Plot No	1604, 1605 subplot no-17(A)
Village Name	KULUPTANGA
Use	Residential
SubUse	Bungalow/ Dwelling / Non Apartment

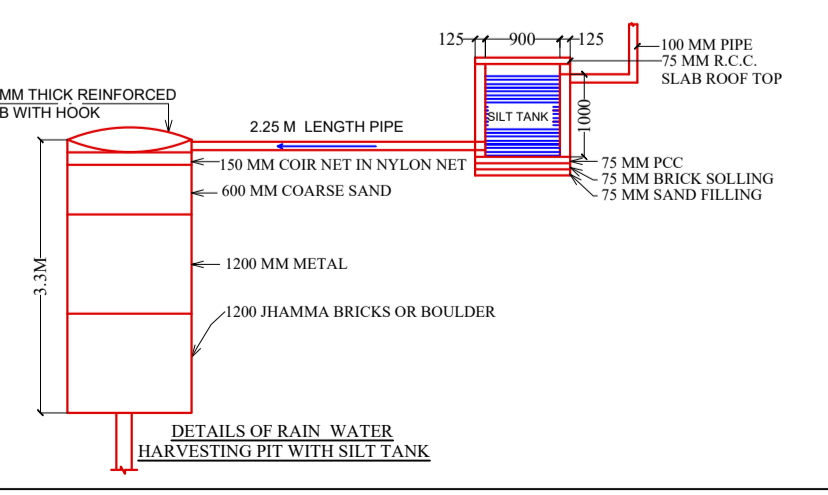
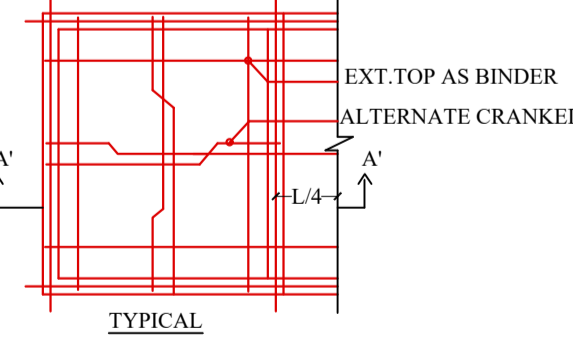
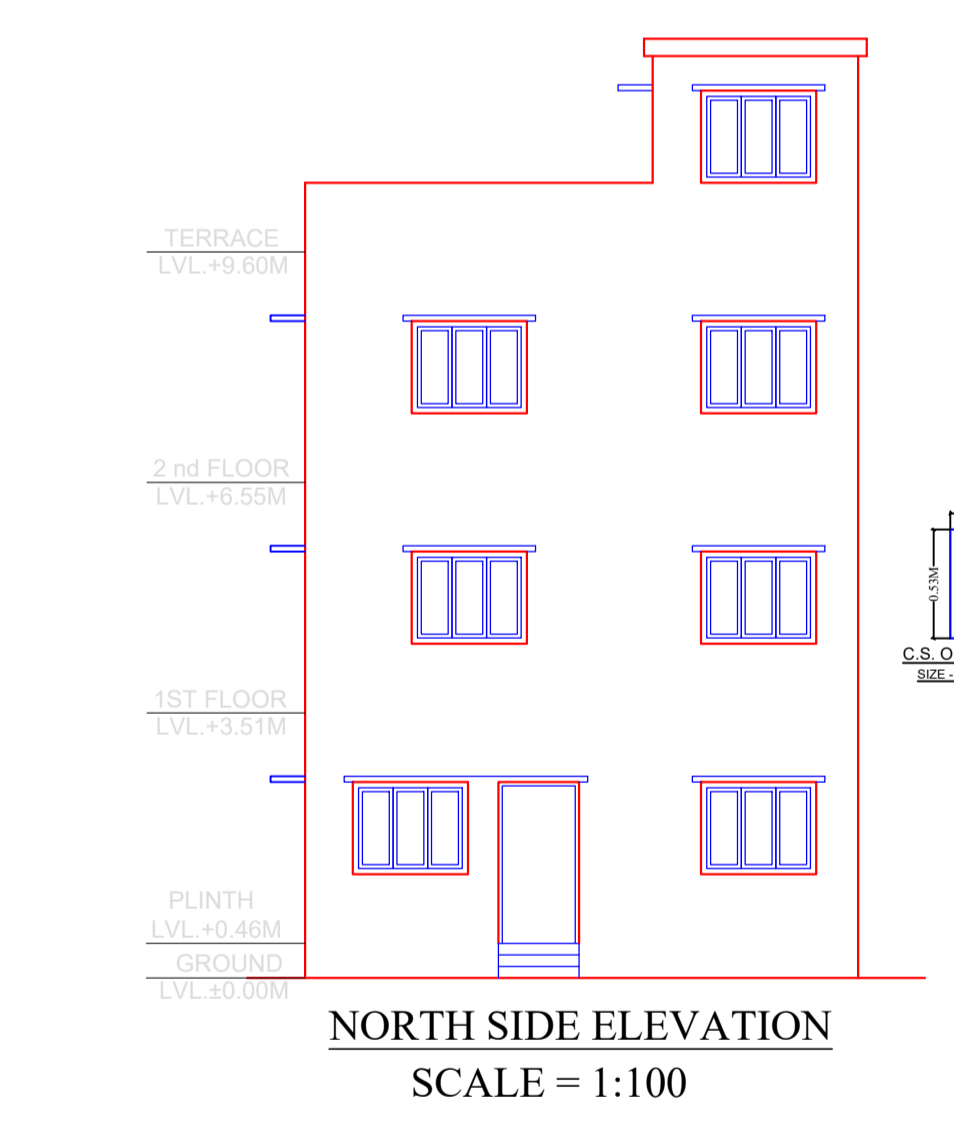
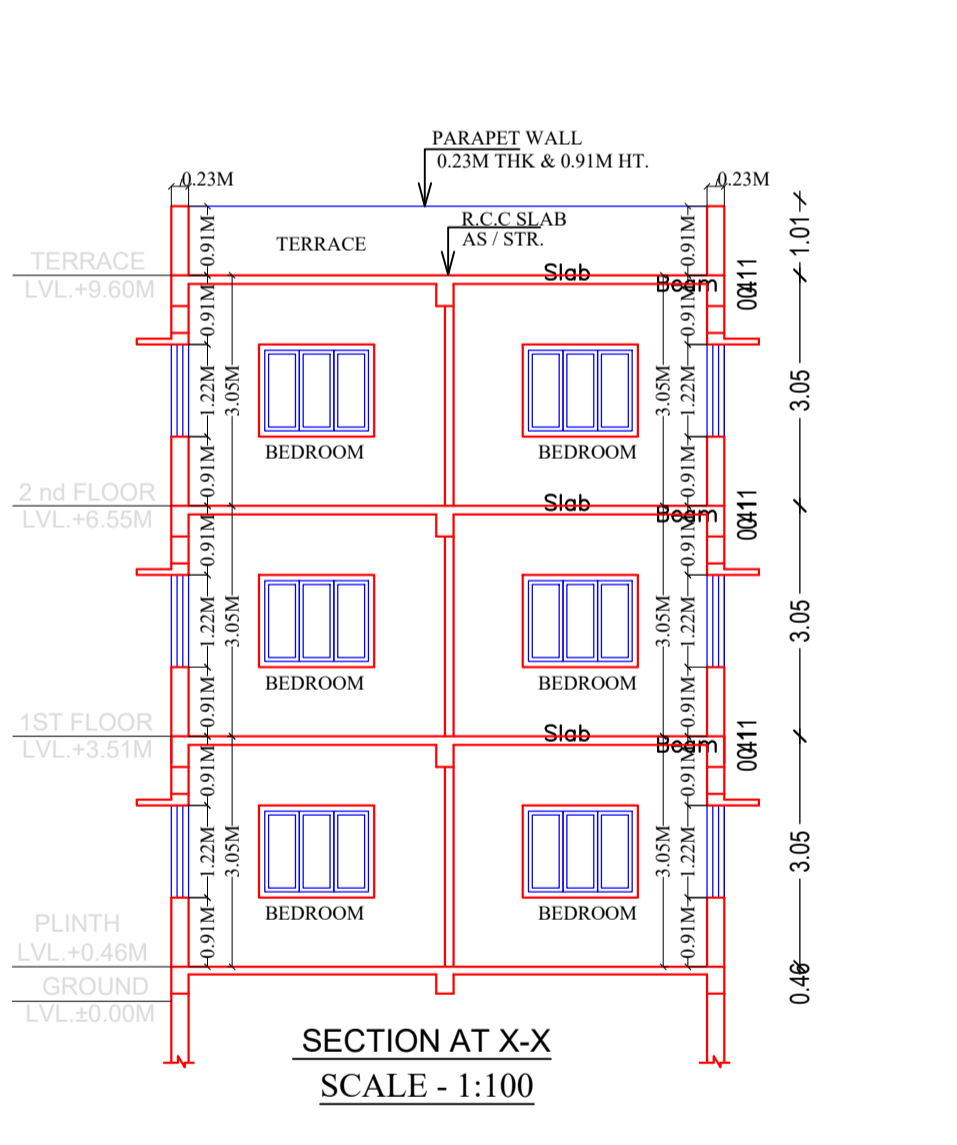
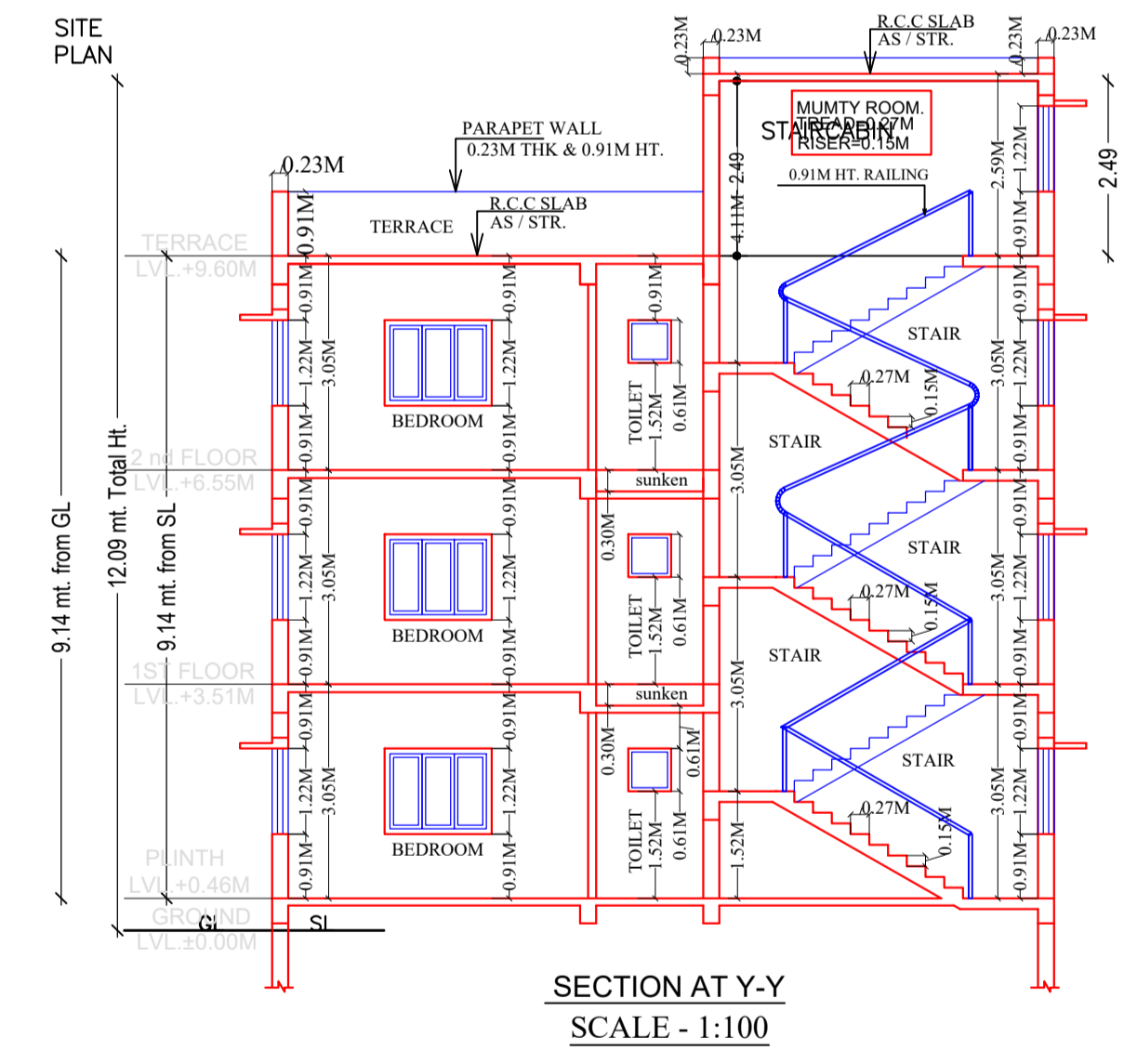
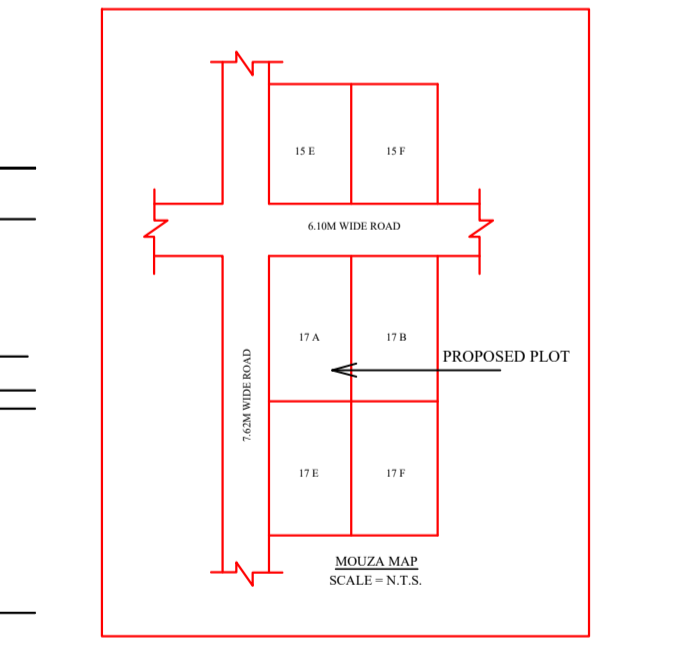
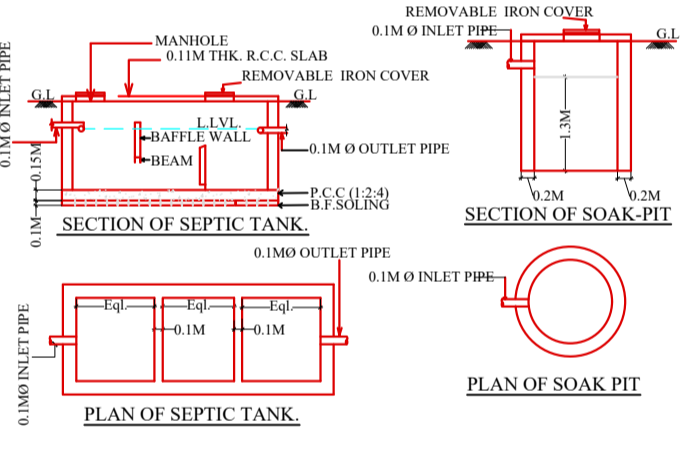
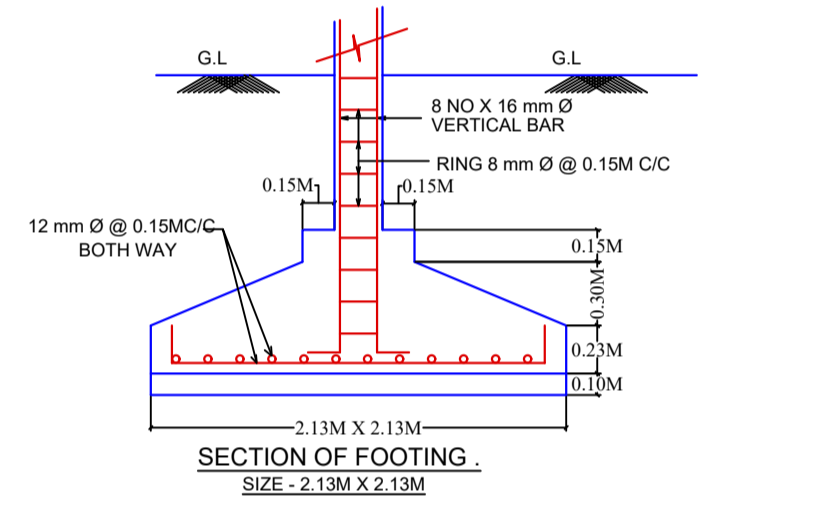
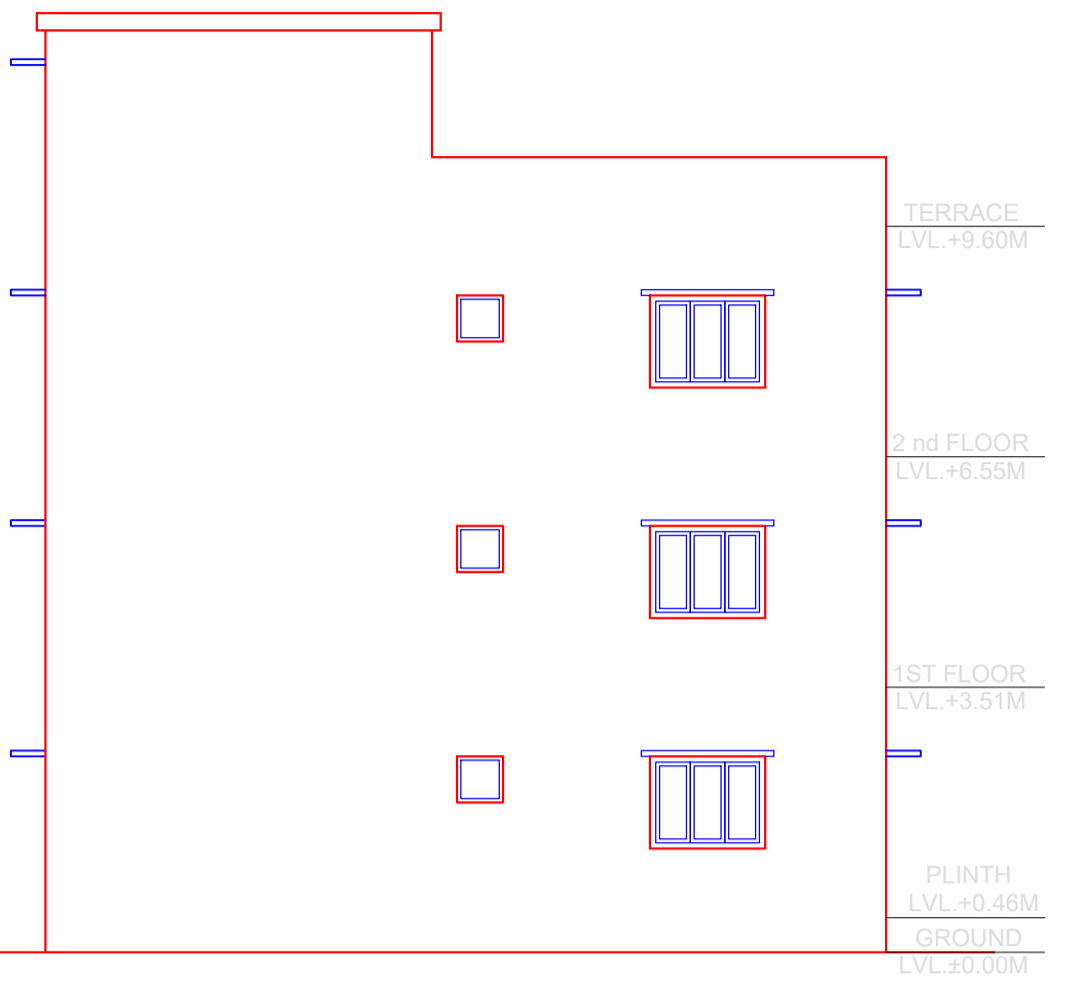
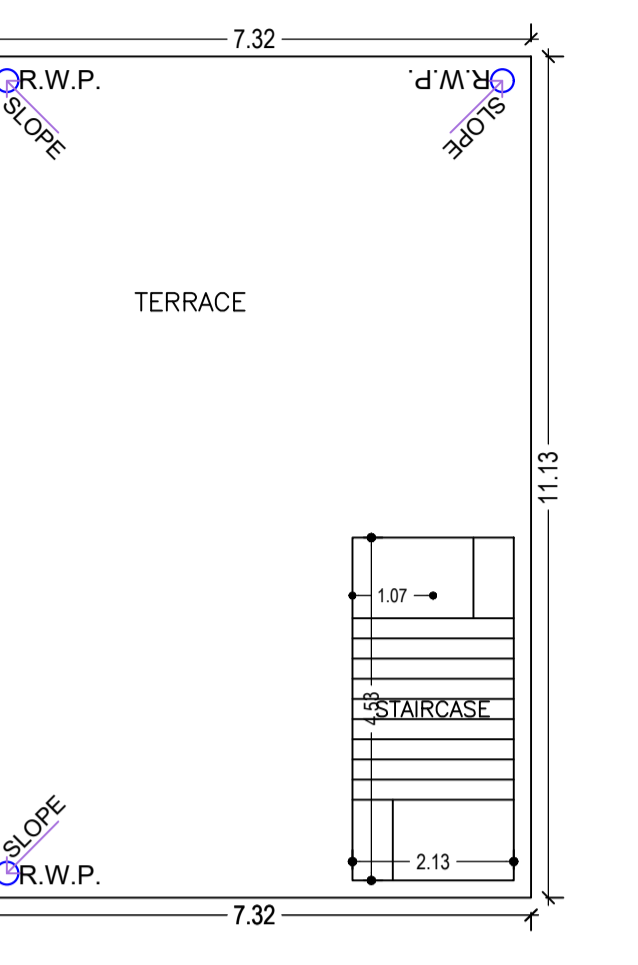
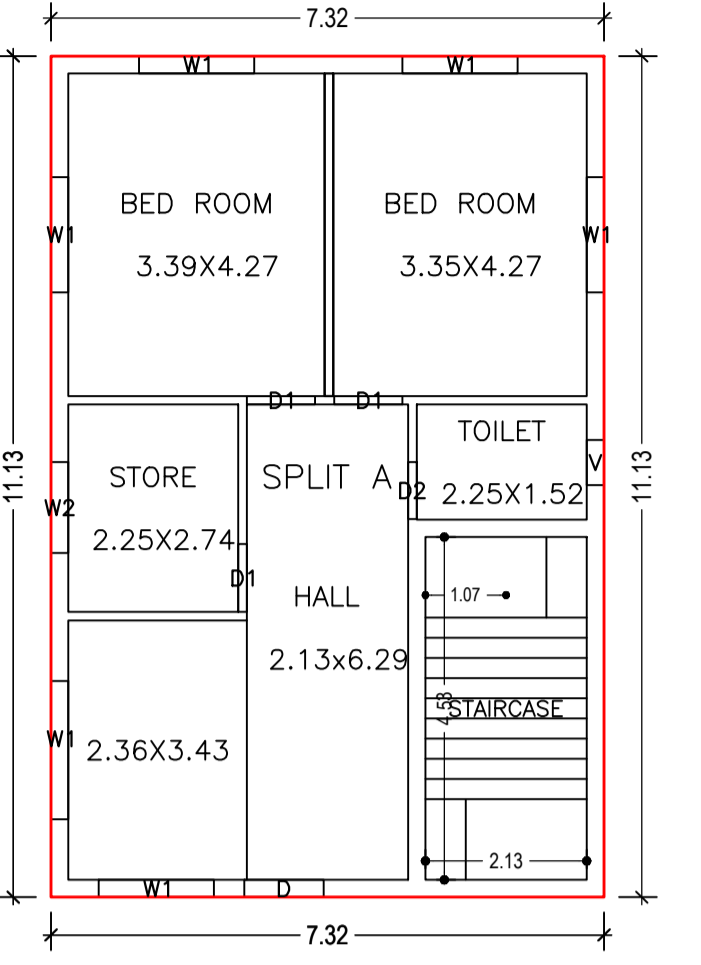
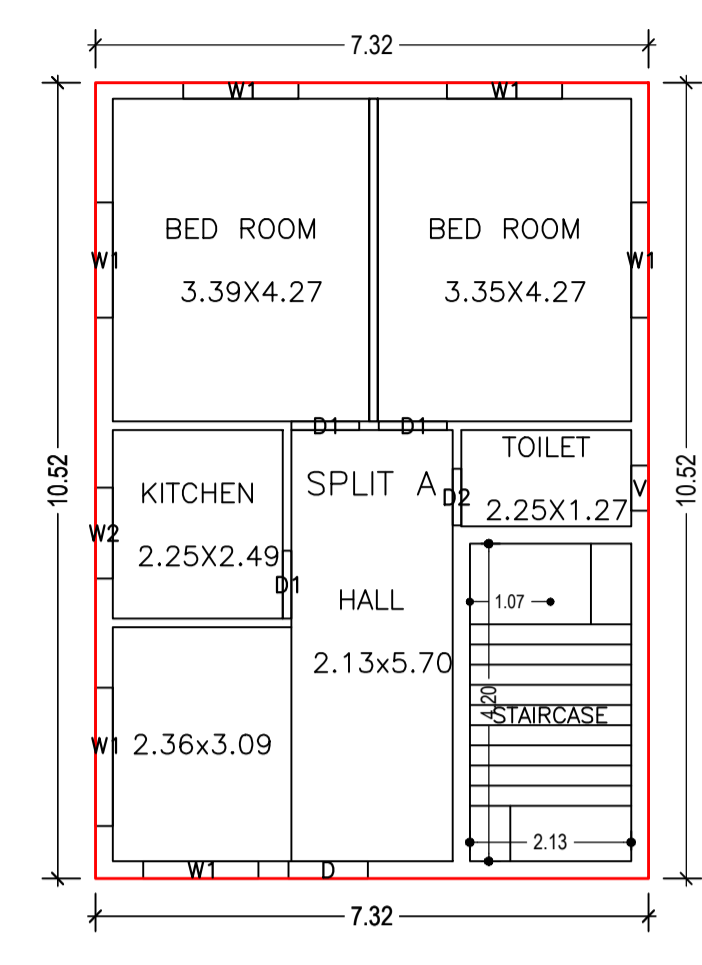
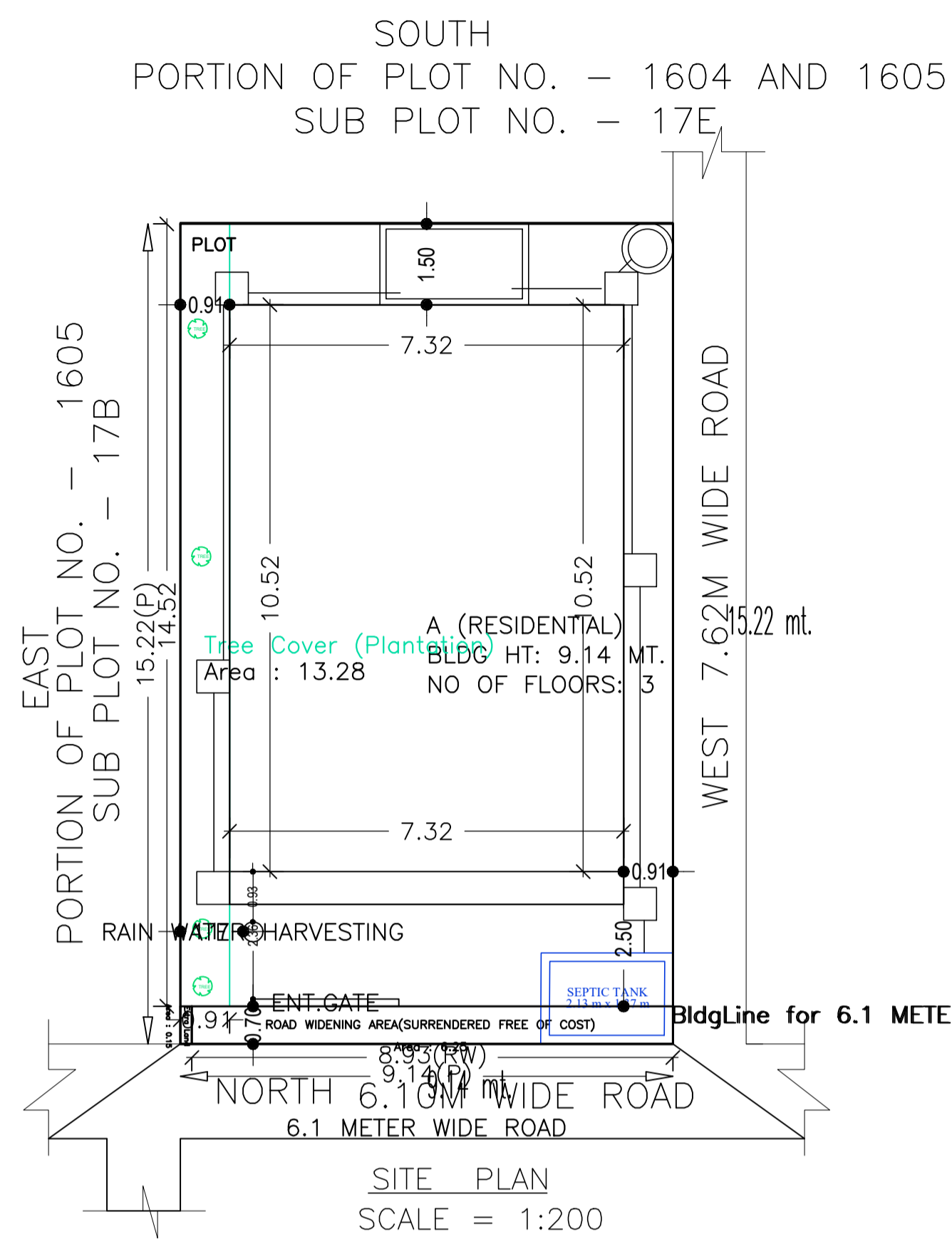

AREA STATEMENT		VERSION NO.: 1.0.55
ADITYAPUR MUNICIPAL CORPORATION		VERSION DATE: 16/10/2020
PROJECT DETAIL:		
Region: JHARKHAND URBAN LOCAL BODIES	Plot Use: Residential	
District: EAST SINGHBHUM	Plot SubUse: Bungalow/ Dwelling / Non Apartment	
Authority: ADITYAPUR MUNICIPAL CORPORATION	PlotNearby/ReligiousStructure: NA	
Inward_No: AMC/BP/0069/W30/2020	Plot/SubPlot No: 1604,1605 subplot no-17(A)	
Application Type: General Proposal	North: Road Width - 6.01	
Project Type: Building Permission	South: Plot No. - PORTION 1604 AND 1605(SUB PLOT NO-17E)	
Nature of Development: New	East: Plot No. - PORTION 1605 (SUB PLOT NO-17B)	
Location of Development Area: New Area	West: Road Width - 7.62	
AREA DETAILS:		SQ.MT.
AREA OF PLOT (Minimum)	(A)	139.20
Deduction for NetPlot Area		
Surrender Free of Cost		6.25
Total		6.25
NET AREA OF PLOT(Gross Plot Area - Deduction from Gross Plot area)	(A-Deductions)	132.95
Deduction for Balance Plot Area(from Gross Plot Area)		
Surrender Free of Cost		6.25
Common Plot		13.28
Total		19.53
BALANCE AREA OF PLOT(Net Plot Area - Recreational/Amenity space)	(A-Deductions)	119.67
PLOT AREA FOR COVERAGE(Net Plot Area)	(A-Deductions)	132.95
Plot Area for FAR (Net Plot Area + RoadWidening Area)	(A-Deductions)	139.20
COVERAGE CHECK		
Permissible Coverage area (70.00 %)		93.06
Proposed Coverage Area (57.91 %)		76.99
Total Prop. Coverage Area (57.91 %)		76.99
Balance coverage area (12.09 %)		16.07
FAR CHECK		
Perm. FAR Area (2.00)		278.40
Total Perm. FAR area		278.40
Residential FAR		239.75
Proposed FAR Area		239.75
Total Proposed FAR Area		239.75
Consumed FAR (Factor)		1.72
Balance FAR Area		38.65
BUILT UP AREA CHECK		
Total Proposed BuiltUp Area		239.75
ARCHITECT (Regd) Abhishek Tewari		
ENGINEER (Regd) PRAMOD KUMAR AND SUNITA ROY		
SUPERVISOR (Regd)		
OWNER (Regd)		
DEVELOPMENT AUTHORITY		LOCAL BODY

COLOR INDEX	
PLOT BOUNDARY	[Red Line]
ABUTTING ROAD	[Green Line]
PROPOSED CONSTRUCTION	[Blue Line]
COMMON PLOT	[Yellow Line]
ROAD WIDENING AREA	[Orange Line]
EXISTING (To be retained)	[Black Line]
EXISTING (To be demolished)	[Grey Line]

Floor Name	Building Name A (RESIDENTIAL)		Total	
	Proposed Built Up Area (Sq.mt.)	Proposed FAR Area (Sq.mt.)	Total Proposed Built Up Area (Sq.mt.)	Total FAR Area (Sq.mt.)
Ground Floor	76.99	76.99	76.99	76.99
First Floor	81.38	81.38	81.38	81.38
Second Floor	81.38	81.38	81.38	81.38
Terrace Floor	0.00	0.00	0.00	0.00
Total :	239.75	239.75	239.75	239.75

Building USE/SUBUSE Details			
Building Name	Building Use	Building SubUse	Building Structure
A (RESIDENTIAL)	Residential	Bungalow/ Dwelling / Non Apartment	Non-Highrise

FAR & Tenement Details (Table 4c-1)						
Building	No. of Same Bldg	Total Built Up Area (Sq.mt.)	Proposed FAR Area (Sq.mt.)	Total FAR Area (Sq.mt.)	Total Consumed Additional FAR Area (Sq.mt.)	Trmnt (No.)
A (RESIDENTIAL)	1	239.75	239.75	239.75	239.75	01
Grand Total :	1	239.75	239.75	239.75	239.75	01

UnitBUA Table for Building :A (RESIDENTIAL)						
FLOOR	Name	UnitBUA Type	UnitBUA Area	Carpet Area	No. of Rooms	No. of Tenement
GROUND FLOOR PLAN	SPLIT A	FLAT	182.51	181.05	5	1
TYPICAL - 1 & 2 FLOOR PLAN	SPLIT A	FLAT	0.00	0.00	5	0
Total:	-	-	182.51	181.05	15	1

SCHEDULE OF DOOR:				
BUILDING NAME	NAME	LENGTH	HEIGHT	NOS
A (RESIDENTIAL)	D2	0.75	2.10	03
A (RESIDENTIAL)	D1	0.90	2.10	09
A (RESIDENTIAL)	D	1.05	2.10	03

SCHEDULE OF WINDOW/VENTILATION:				
BUILDING NAME	NAME	LENGTH	HEIGHT	NOS
A (RESIDENTIAL)	V	0.60	0.75	03
A (RESIDENTIAL)	W2	1.20	1.20	03
A (RESIDENTIAL)	W1	1.52	1.20	15
A (RESIDENTIAL)	W1	1.83	1.20	03

Building :A (RESIDENTIAL)					
Floor Name	Total Built Up Area (Sq.mt.)	Proposed FAR Area (Sq.mt.)	Total FAR Area (Sq.mt.)	Total Consumed Additional FAR Area (Sq.mt.)	Trmnt (No.)
Ground Floor	76.99	76.99	76.99	76.99	01
First Floor	81.38	81.38	81.38	81.38	00
Second Floor	81.38	81.38	81.38	81.38	00
Terrace Floor	0.00	0.00	0.00	0.00	00
Total :	239.75	239.75	239.75	239.75	01
Total Number of Same Buildings	1				
Total :	239.75	239.75	239.75	239.75	01

LTP NAME AND SIGNATURE	STRUCTURAL ENG'S NAME AND SIGNATURE	BUILDER NAME AND SIGNATURE	DIGITAL SIGNATURE
Abhishek Tewari AMC/ARC/0026/2016			