

Proposal Basic Information	
Proposal File No.	AMC/BP/0073/W11/2020
Owner Name	SMT KALPANA YADAV
Khata No	857
Plot No	3314
Village Name	BADA GMBHARIA
Use	Residential
SubUse	Bungalow/ Dwelling / Non Apartment

AREA STATEMENT		VERSION NO.: 1.0.55
ADITYAPUR MUNICIPAL CORPORATION		VERSION DATE: 16/10/2020
PROJECT DETAIL:		
Region: JHARKHAND URBAN LOCAL BODIES	Plot Use: Residential	
District: EAST SINGHBHUM	Plot SubUse: Bungalow/ Dwelling / Non Apartment	
Authority: ADITYAPUR MUNICIPAL CORPORATION	PlotNearbyReligiousStructure: NA	
Inward No: AMC/BP/0073/W11/2020	Plot/SubPlot No: 3314	
Application Type: General Proposal	North: -	
Project Type: Building Permission	South: -	
Nature of Development: New	East: -	
Location of Development Area: Old Area	West: Road Width - 6.10	
AREA DETAILS:		
AREA OF PLOT (Minimum)	(A)	SQ.MT. 350.37
NET AREA OF PLOT(Gross Plot Area - Deduction from Gross Plot area)	(A-Deductions)	350.37
Deduction for Balance Plot Area(from Gross Plot Area)		
Common Plot		63.01
Total		63.01
BALANCE AREA OF PLOT(Net Plot Area - Recreational/Amenity space)	(A-Deductions)	287.36
PLOT AREA FOR COVERAGE(Net Plot Area)	(A-Deductions)	350.37
Plot Area for FAR (Net Plot Area + RoadWidening Area)	(A-Deductions)	350.37
COVERAGE CHECK		
Permissible Coverage area (60.00 %)		210.22
Proposed Coverage Area (37.83 %)		132.53
Total Prop. Coverage Area (37.83 %)		132.53
Balance coverage area (22.17 %)		77.69
FAR CHECK		
Perm. FAR Area (2.50)		875.92
Total Perm. FAR area		875.92
Residential FAR		203.59
Proposed FAR Area		203.59
Total Proposed FAR Area		203.59
Consumed FAR (Factor)		0.58
Balance FAR Area		672.33
BUILT UP AREA CHECK		
Total Proposed BuiltUp Area		265.05
ARCHITECT (Regd)		NIKHIL SHUKLA
ENGINEER (Regd)		
SUPERVISOR (Regd)		
OWNER (Regd)		SMT KALPANA YADAV
DEVELOPMENT AUTHORITY		LOCAL BODY

Building :A (RESIDENTIAL)

Floor Name	Total Built Up Area (Sq.mt.)	Deductions (Area in Sq.mt.)	Proposed FAR Area (Sq.mt.)	Total FAR Area (Sq.mt.)	Total Consumed Additional FAR Area (Sq.mt.)	Tnmt (No.)
Ground Floor	132.52	61.46	71.06	71.06	71.06	01
First Floor	132.53	0.00	132.53	132.53	132.53	00
Terrace Floor	0.00	0.00	0.00	0.00	0.00	00
Total :	265.05	61.46	203.59	203.59	203.59	01

COLOR INDEX

PLOT BOUNDARY	Black
ABUTTING ROAD	Green
PROPOSED CONSTRUCTION	Red
COMMON PLOT	Yellow
ROAD WIDENING AREA	Blue
EXISTING (To be retained)	Orange
EXISTING (To be demolished)	Light Blue

Buildingwise Floor FAR Details

Floor Name	Building Name A (RESIDENTIAL)		Total	
	Proposed Built Up Area (Sq.mt.)	Proposed FAR Area (Sq.mt.)	Total Proposed Built Up Area (Sq.mt.)	Total FAR Area (Sq.mt.)
Ground Floor	132.52	71.06	132.52	71.06
First Floor	132.53	132.53	132.53	132.53
Terrace Floor	0.00	0.00	0.00	0.00
Total :	265.05	203.59	265.05	203.59

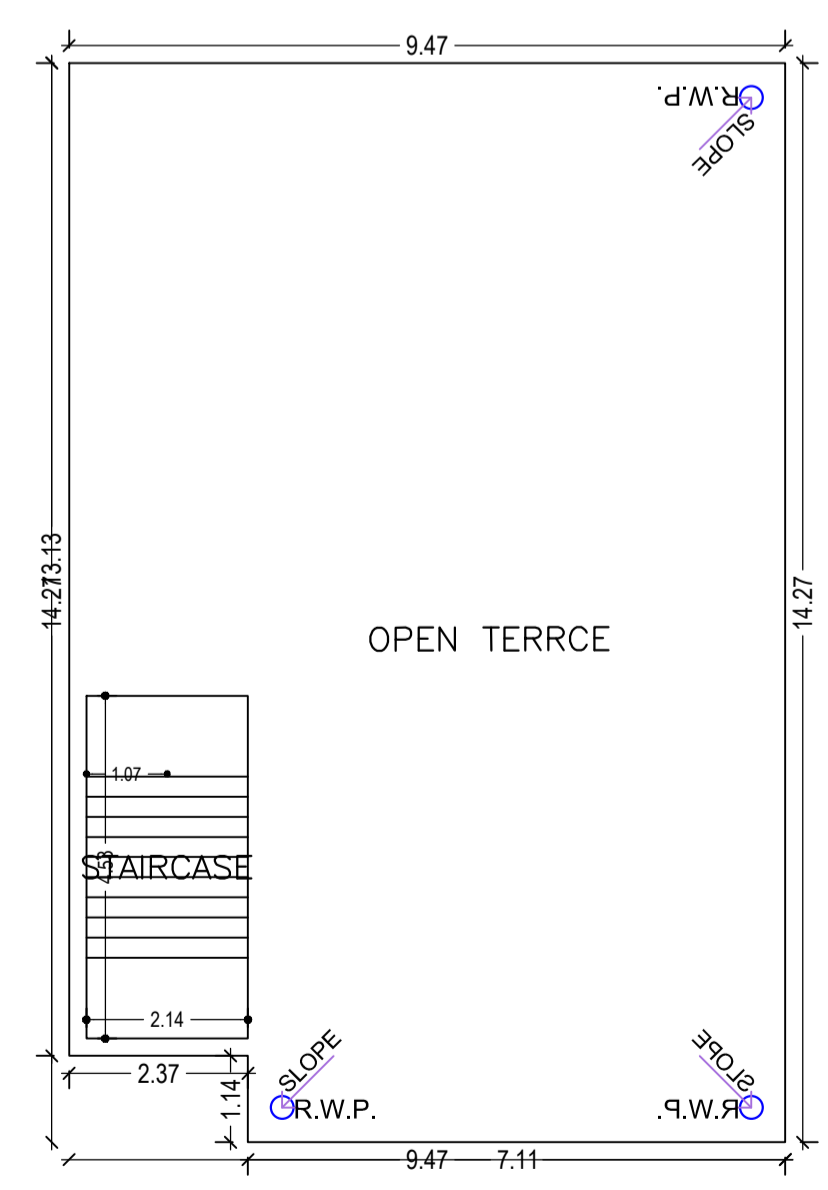
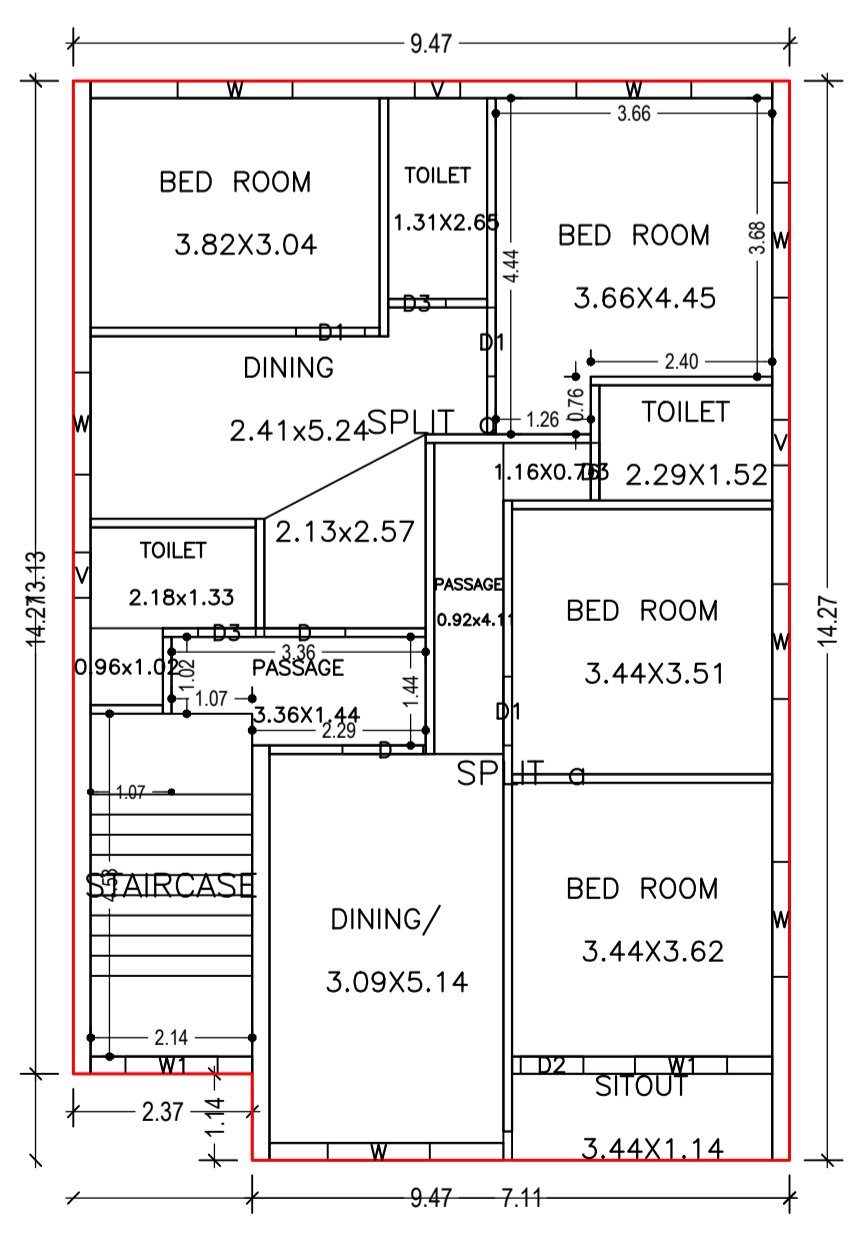
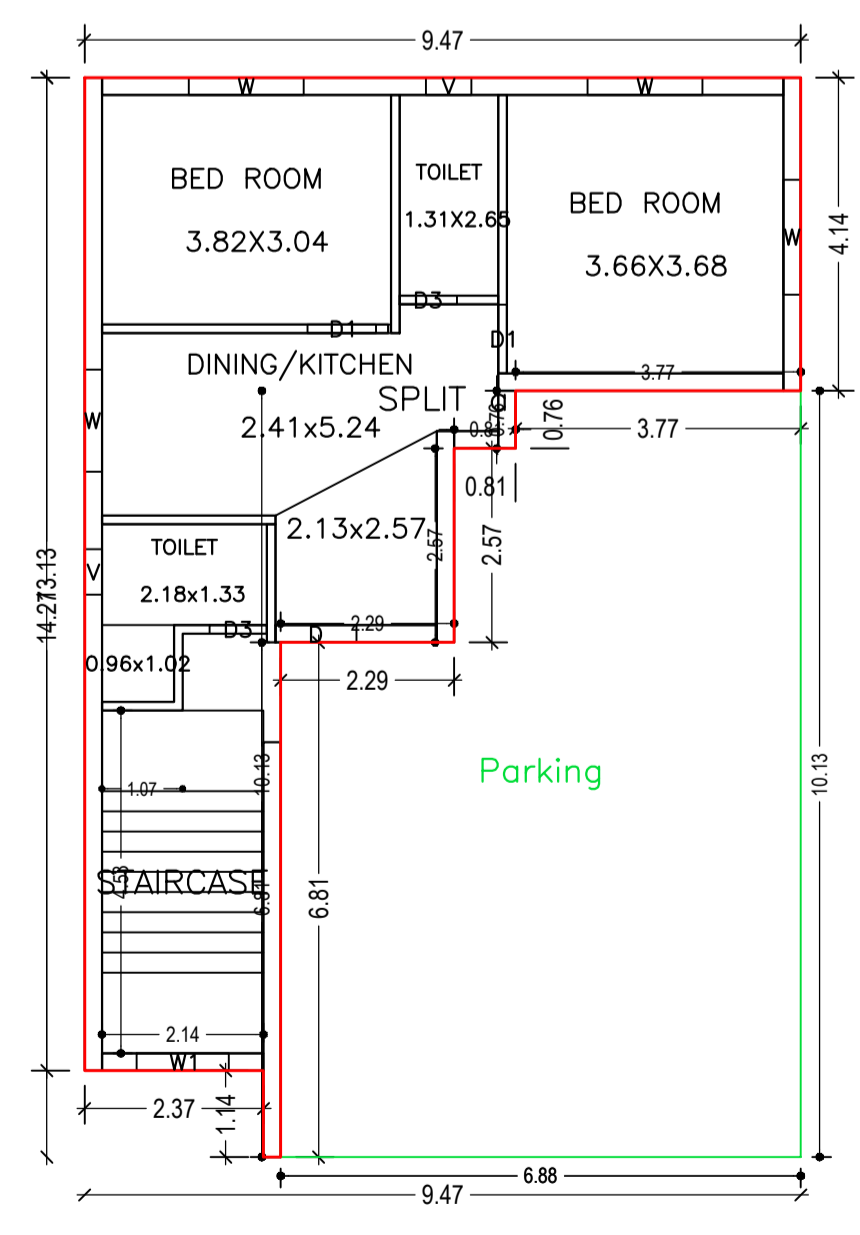

LTP NAME AND SIGNATURE	STRUCTURAL ENG'S NAME AND SIGNATURE	BUILDER NAME AND SIGNATURE	DIGITAL SIGNATURE
NIKHIL SHUKLA AMC/ARC/0045/2017			

Proposal Basic Information	
Proposal File No.	AMC/BP/0073/W11/2020
Owner Name	SMT KALPANA YADAV
Khata No	857
Plot No	3314
Village Name	BADA GMBHARIA
Use	Residential
SubUse	Bungalow/ Dwelling / Non Apartment

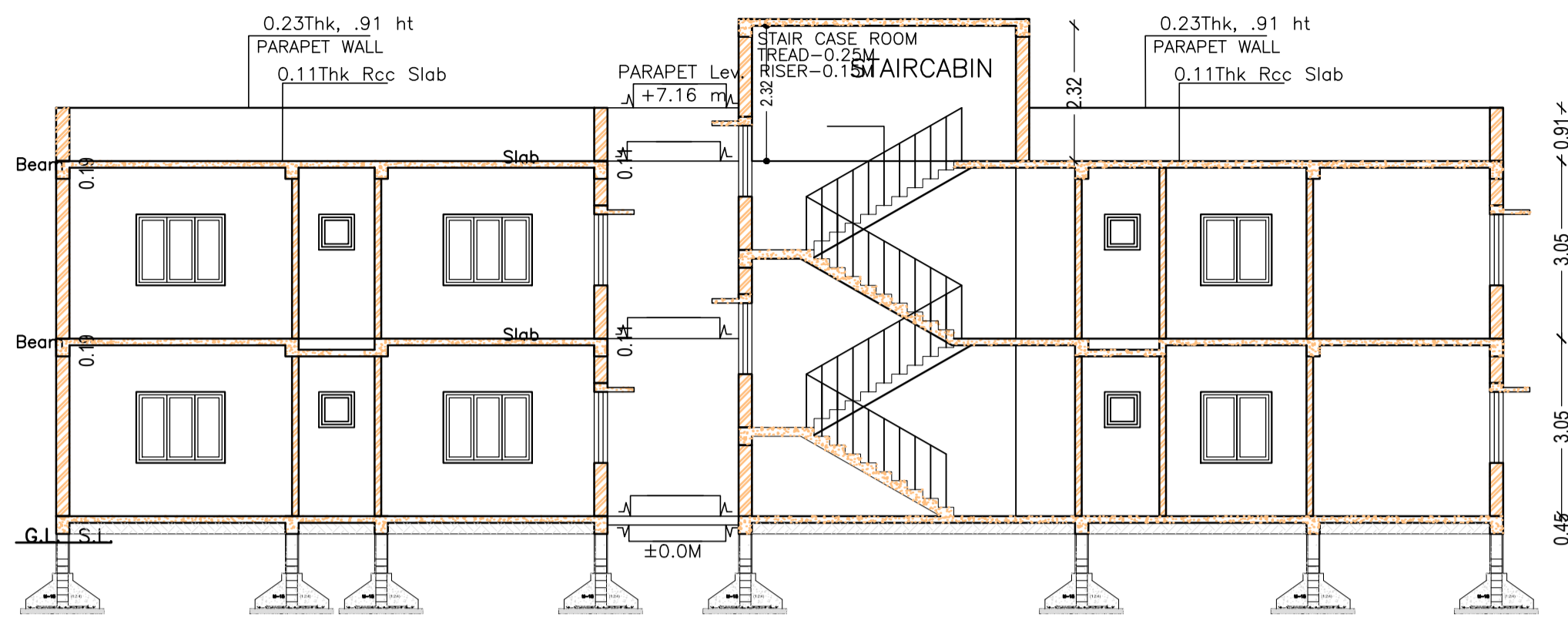

SECTION AT- XX
SCALE- 1:100

SECTION AT -YY
SCALE- 1:100

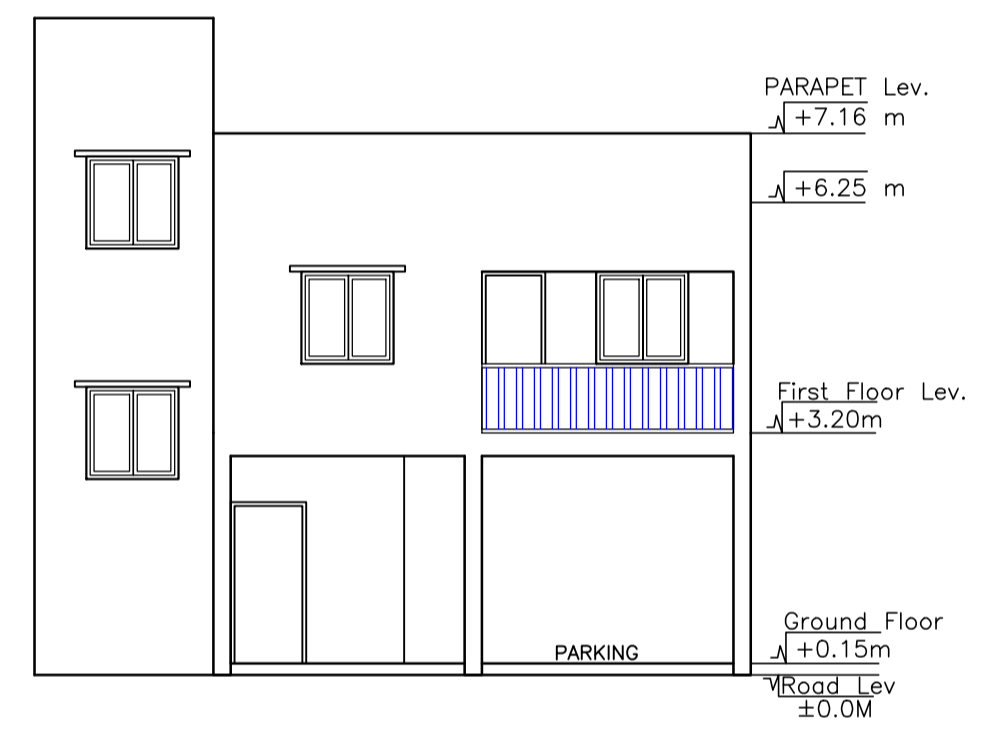

FRONT SIDE ELEVATION
SCALE- 1:100

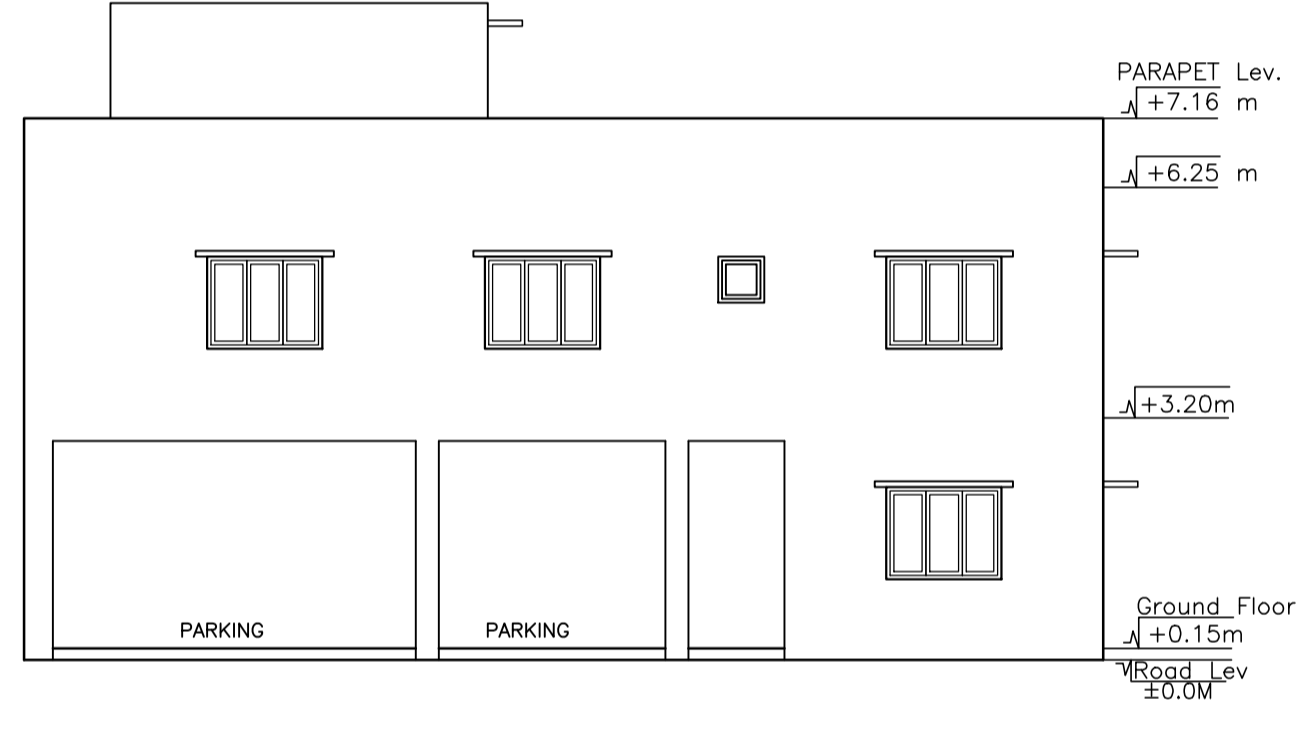

RIGHT SIDE ELEVATION
SCALE- 1:100

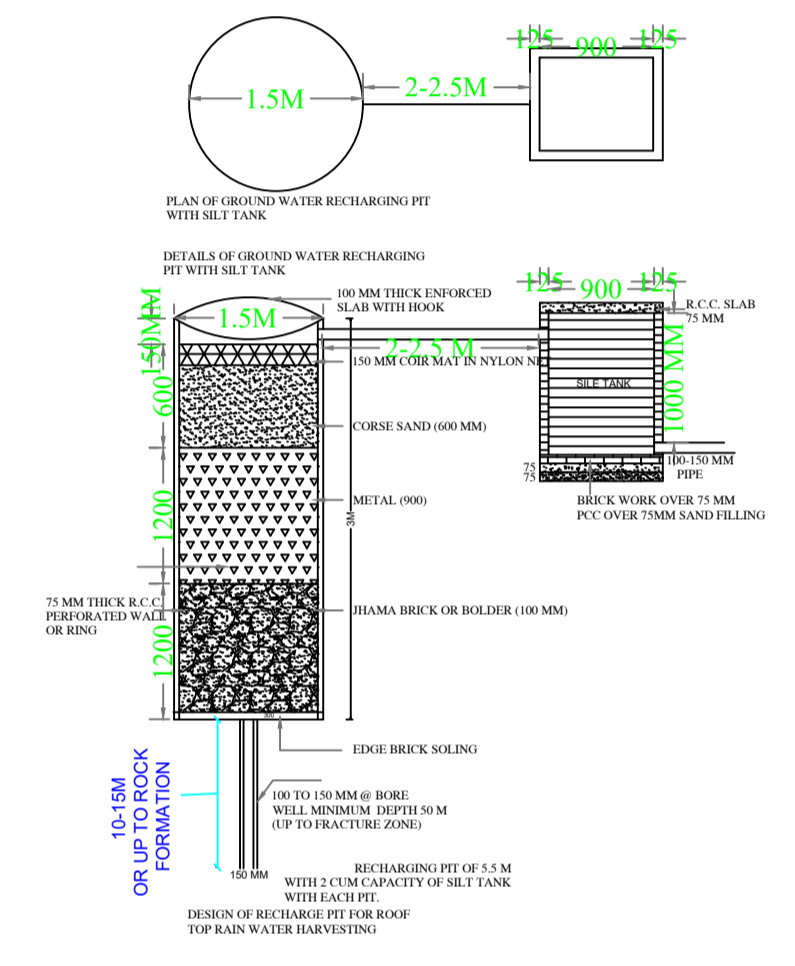

RAIN WATER STORAGE TANK DETAIL

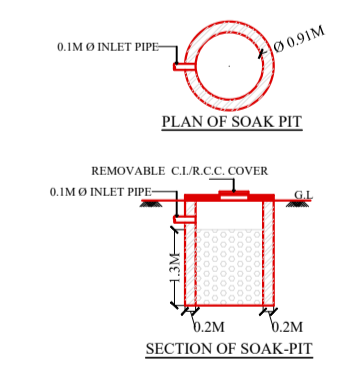
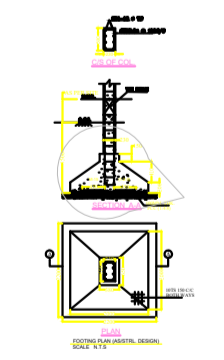
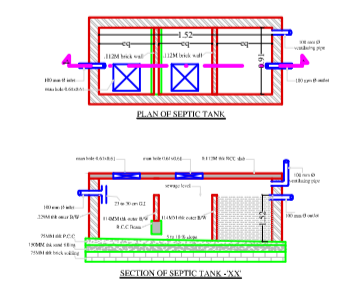
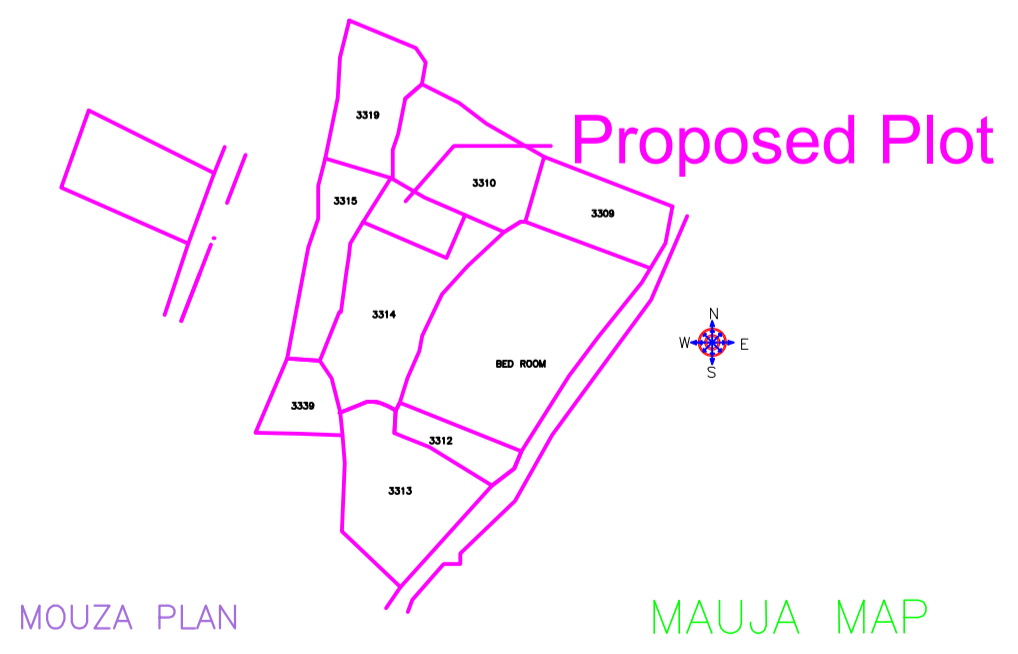

UnitBUA Table for Building :A (RESIDENTIAL)

FLOOR	Name	UnitBUA Type	UnitBUA Area	Carpet Area	No. of Rooms	No. of Tenement
GROUND FLOOR PLAN	SPLIT a	FLAT	160.15	153.61	5	1
FIRST FLOOR PLAN	SPLIT a	FLAT	0.00	0.00	6	0
Total:	-	-	160.15	153.61	17	1

SCHEDULE OF DOOR:

BUILDING NAME	NAME	LENGTH	HEIGHT	NOS
A (RESIDENTIAL)	D3	0.76	2.10	05
A (RESIDENTIAL)	D2	0.83	2.10	01
A (RESIDENTIAL)	D1	0.91	2.10	05
A (RESIDENTIAL)	D	1.07	2.10	03

SCHEDULE OF WINDOW/VENTILATION:

BUILDING NAME	NAME	LENGTH	HEIGHT	NOS
A (RESIDENTIAL)	V	0.60	0.60	05
A (RESIDENTIAL)	W1	1.22	1.20	03
A (RESIDENTIAL)	W	1.35	1.20	03
A (RESIDENTIAL)	W	1.52	1.20	08

FAR & Tenement Details (Table 4c-1)

Building	No. of Same Bldg	Total Built Up Area (Sq.mt.)	Deductions (Area in Sq.mt.)		Proposed FAR Area (Sq.mt.)	Total FAR Area (Sq.mt.)	Total Consumed Additional FAR Area (Sq.mt.)	Trnmt (No.)
			Parking	Resi.				
A (RESIDENTIAL)	1	265.05	61.46	203.59	203.59	203.59	01	
Grand Total	1	265.05	61.46	203.59	203.59	203.59	01	

Building USE/SUBUSE Details

Building Name	Building Use	Building SubUse	Building Structure
A (RESIDENTIAL)	Residential	Bungalow/ Dwelling / Non Apartment	Non-Highrise

LTP NAME AND SIGNATURE	STRUCTURAL ENG'S NAME AND SIGNATURE	BUILDER NAME AND SIGNATURE	DIGITAL SIGNATURE
NIKHIL SHUKLA AMC/ARC/0045/2017			