

UnitBUA Table for Building :A(TBCPL)

FLOOR	Name	UnitBUA Type	UnitBUA Area	Carpet Area	No. of Rooms	No. of Tenement
GROUND FLOOR PLAN	SPLIT ABC	FLAT	89.98	87.40	3	1
FIRST FLOOR PLAN	SPLIT ABC	FLAT	0.00	0.00	6	0
Total:	-	-	89.98	87.40	9	1

Building :A(TBCPL)

Floor Name	Total Built Up Area (Sq.mt.)	Proposed FAR Area (Sq.mt.) Resi.	Total FAR Area (Sq.mt.)	Total Consumed Additional FAR Area (Sq.mt.)	Tnmt (No.)
Ground Floor	45.57	45.57	45.57	45.57	01
First Floor	50.54	50.54	50.54	50.54	00
Terrace Floor	0.00	0.00	0.00	0.00	00
Total :	96.11	96.11	96.11	96.11	01
Total Number of Same Buildings :	1				
Total :	96.11	96.11	96.11	96.11	01

SCHEDULE OF DOOR:

BUILDING NAME	NAME	LENGTH	HEIGHT	NOS
A(TBCPL)	D2	0.76	2.13	06
A(TBCPL)	D1	0.99	2.13	02

SCHEDULE OF WINDOW/VENTILATION:

BUILDING NAME	NAME	LENGTH	HEIGHT	NOS
A(TBCPL)	V	0.76	0.61	02
A(TBCPL)	W2	0.91	1.22	04
A(TBCPL)	W1	1.22	1.22	04

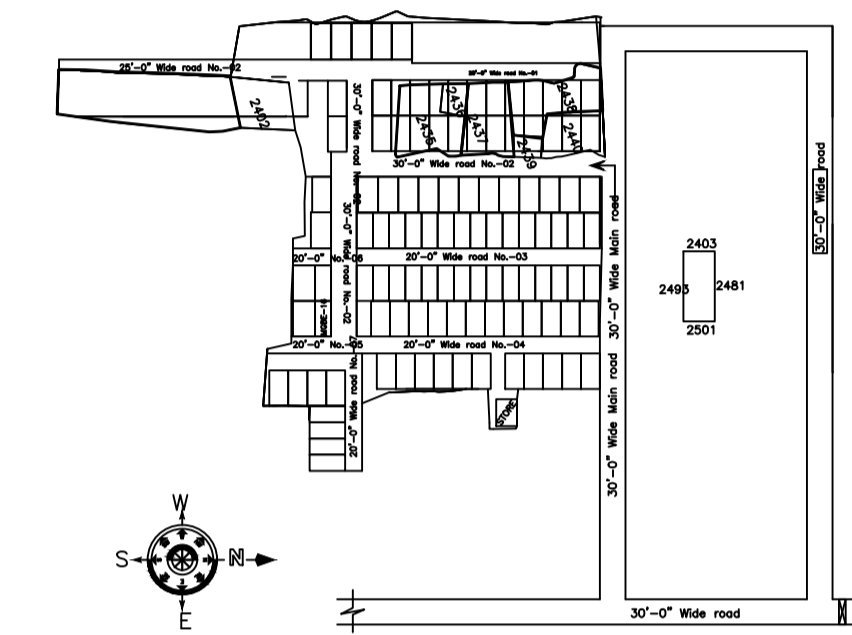

LOCATION PLAN (NOT TO SCALE)

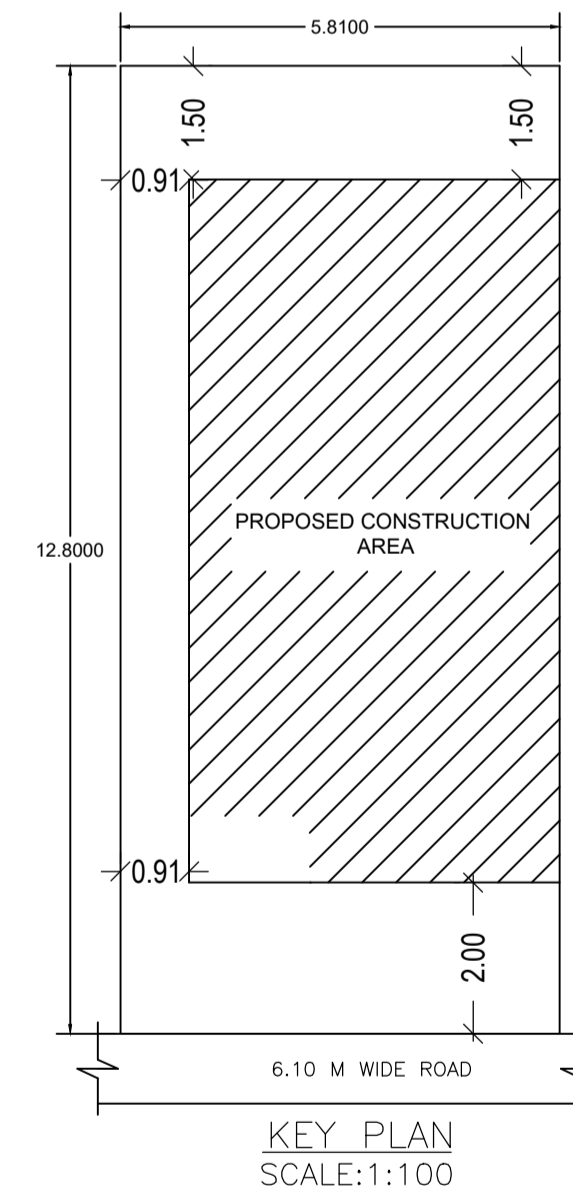
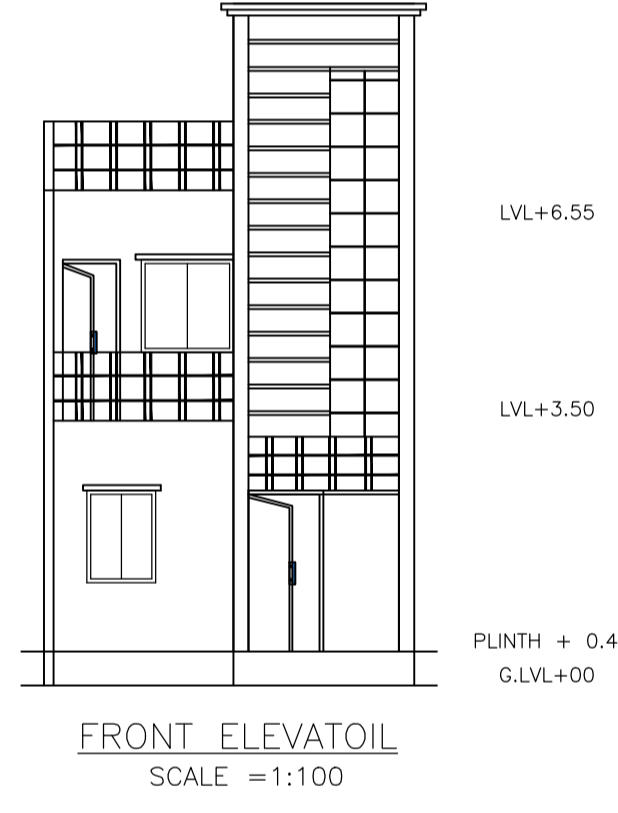
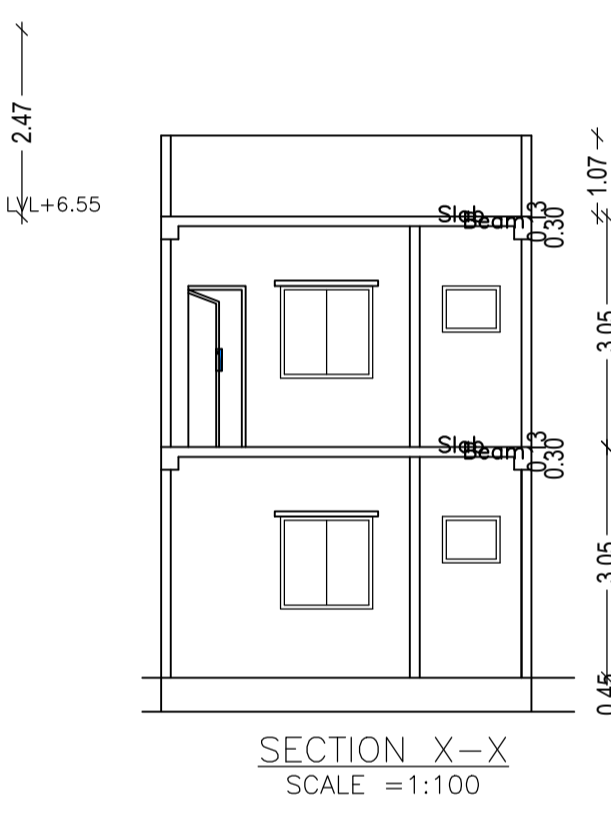
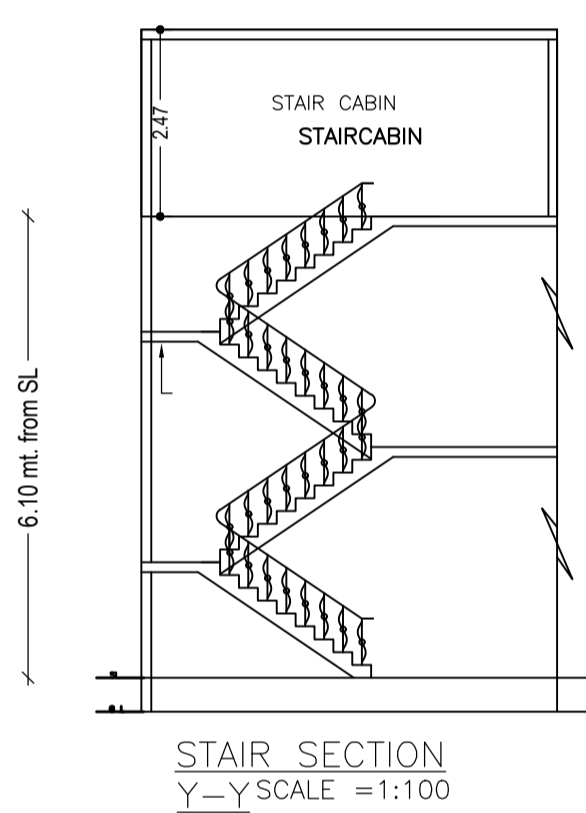
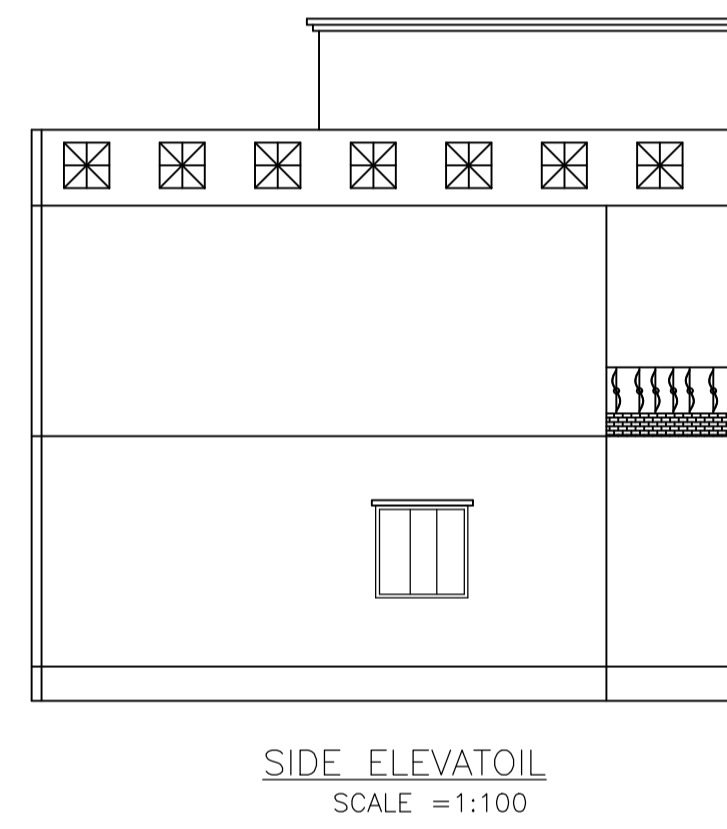

AREA STATEMENT		VERSION NO.:	1.0.62
ADITYAPUR MUNICIPAL CORPORATION		VERSION DATE: 16/10/2020	
PROJECT DETAIL:			
Region: JHARKHAND URBAN LOCAL BODIES	Plot Use: Residential		
District: EAST SINGHBHUM	Plot SubUse: Bungalow/ Dwelling / Non Apartment		
Authority: ADITYAPUR MUNICIPAL CORPORATION	PlotNearby/ReligiousStructure: NA		
Inward No: AMC/BP/0091/M22/2021	Plot/SubPlot No: 453(OLD), 2492(NEW)		
Application Type: General Proposal	North: Plot No. - 435/2492		
Project Type: Building Permission	South: Plot No. - BOUNDARY		
Nature of Development: New	East: Road Width - 6.1		
Location of Development Area: Old Area	West: Plot No. - 453/2492		
AREA DETAILS:			
AREA OF PLOT (Minimum)	(A)	SQ.MT.	
NET AREA OF PLOT (Gross Plot Area - Deduction from Gross Plot Area)	(A-Deductions)	74.37	
Deduction for Balance Plot Area (from Gross Plot Area)			
Common Plot		5.61	
Total		5.61	
BALANCE AREA OF PLOT (Net Plot Area - Recreational/Amenity space)	(A-Deductions)	68.76	
PLOT AREA FOR COVERAGE (Net Plot Area)	(A-Deductions)	74.37	
Plot Area for FAR (Net Plot Area + Road Widening Area)	(A-Deductions)	74.37	
COVERAGE CHECK			
Permissible Coverage area (70.00 %)		52.06	
Proposed Coverage Area (61.28 %)		45.57	
Total Prop. Coverage Area (61.28 %)		45.57	
Balance coverage area (8.73 %)		6.49	
FAR CHECK			
Perm. FAR Area (2.50)		185.93	
Total Perm. FAR area		185.93	
Residential FAR		96.11	
Proposed FAR Area		96.11	
Total Proposed FAR Area		96.11	
Consumed FAR (Factor)		1.29	
Balance FAR Area		89.82	
BUILT UP AREA CHECK			
Total Proposed BuiltUp Area		96.11	
ARCHITECT (Regd)	MOHAMMAD BELAL NASIR		
ENGINEER (Regd)			
SUPERVISOR (Regd)			
OWNER (Regd)	TECHNOCULTURE BUILDING CENTRE PRIVATE LIMITED		
DEVELOPMENT AUTHORITY		LOCAL BODY	

COLOR INDEX	
PLOT BOUNDARY	Black
ABUTTING ROAD	Green
PROPOSED CONSTRUCTION	Red
COMMON PLOT	Yellow
ROAD WIDENING AREA	Blue
EXISTING (To be retained)	Grey
EXISTING (To be demolished)	White

Floor Name	Building Name		Total	
	Proposed Built Up Area (Sq.mt.)	Proposed FAR Area (Sq.mt.)	Total Proposed Built Up Area (Sq.mt.)	Total FAR Area (Sq.mt.)
Ground Floor	45.57	45.57	45.57	45.57
First Floor	50.54	50.54	50.54	50.54
Terrace Floor	0.00	0.00	0.00	0.00
Total :	96.11	96.11	96.11	96.11

Building USE/SUBUSE Details			
Building Name	Building Use	Building SubUse	Building Structure
A(TBCPL)	Residential	Residential Bldg/Apartment	Non-Highrise

FAR & Tenement Details (Table 4c-1)						
Building	No. of Same Bldg	Total Built Up Area (Sq.mt.)	Proposed FAR Area (Sq.mt.) Resi.	Total FAR Area (Sq.mt.)	Total Consumed Additional FAR Area (Sq.mt.)	Tnmt (No.)
A(TBCPL)	1	96.11	96.11	96.11	96.11	01
Grand Total :	1	96.11	96.11	96.11	96.11	01

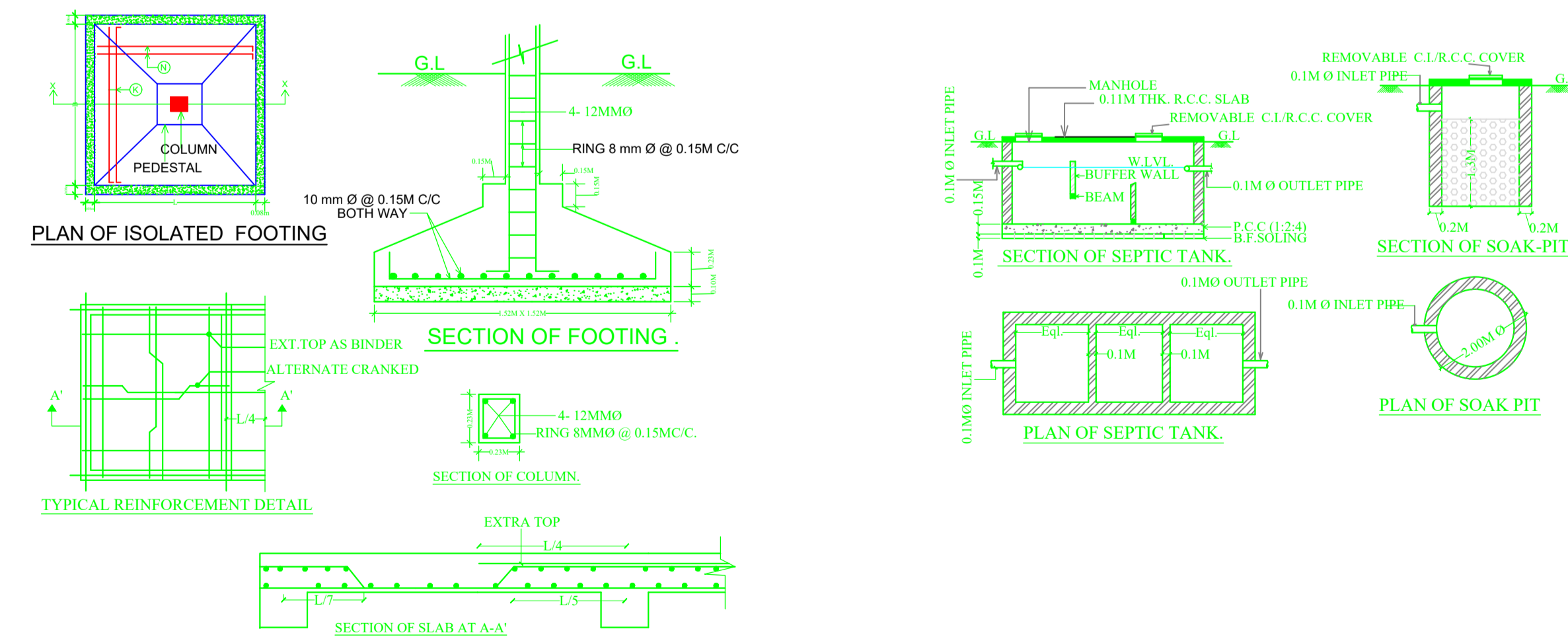

LTP NAME AND SIGNATURE	STRUCTURAL ENG'S NAME AND SIGNATURE	BUILDER NAME AND SIGNATURE	DIGITAL SIGNATURE
MOHAMMAD BELAL NASIR AMC/ENG/00152017			