

Proposal Basic Information

Proposal File No.	AMC/BP/0001/W22/2021
Owner Name	BRIJA NAND BHAGAT AND SUMITA BHAGAT
Khata No	222
Plot No	1213
Village Name	ASANGI
Use	Residential
SubUse	Bungalow/ Dwelling / Non Apartment

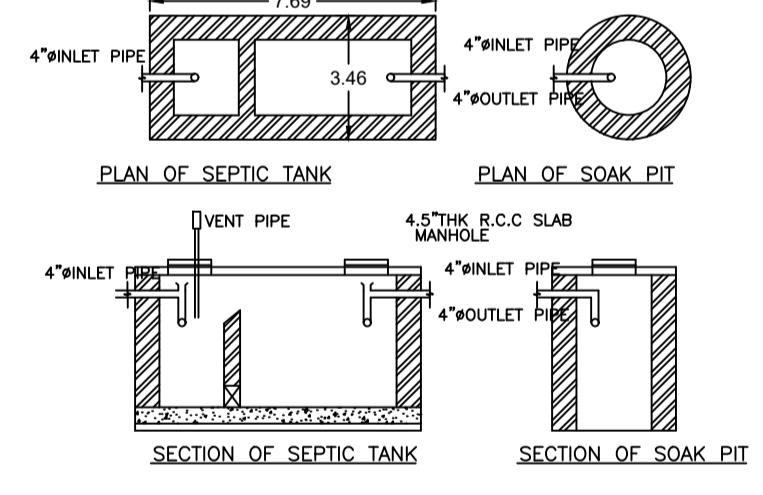
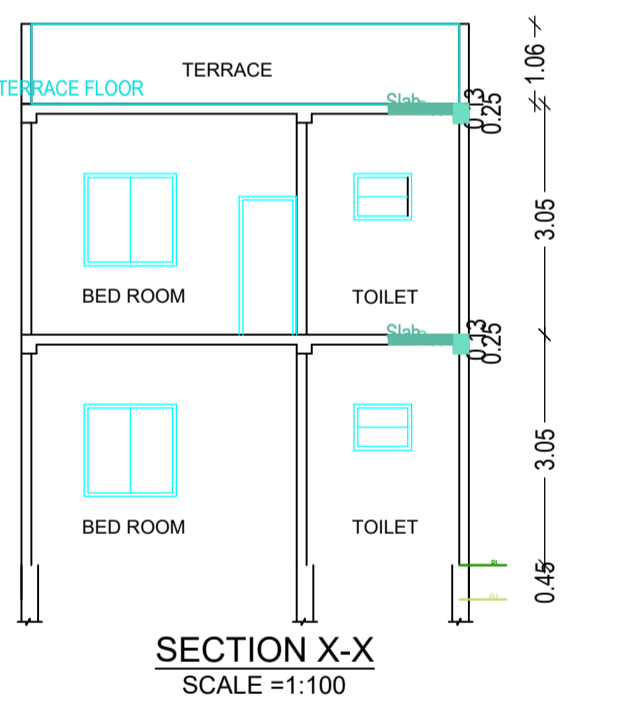
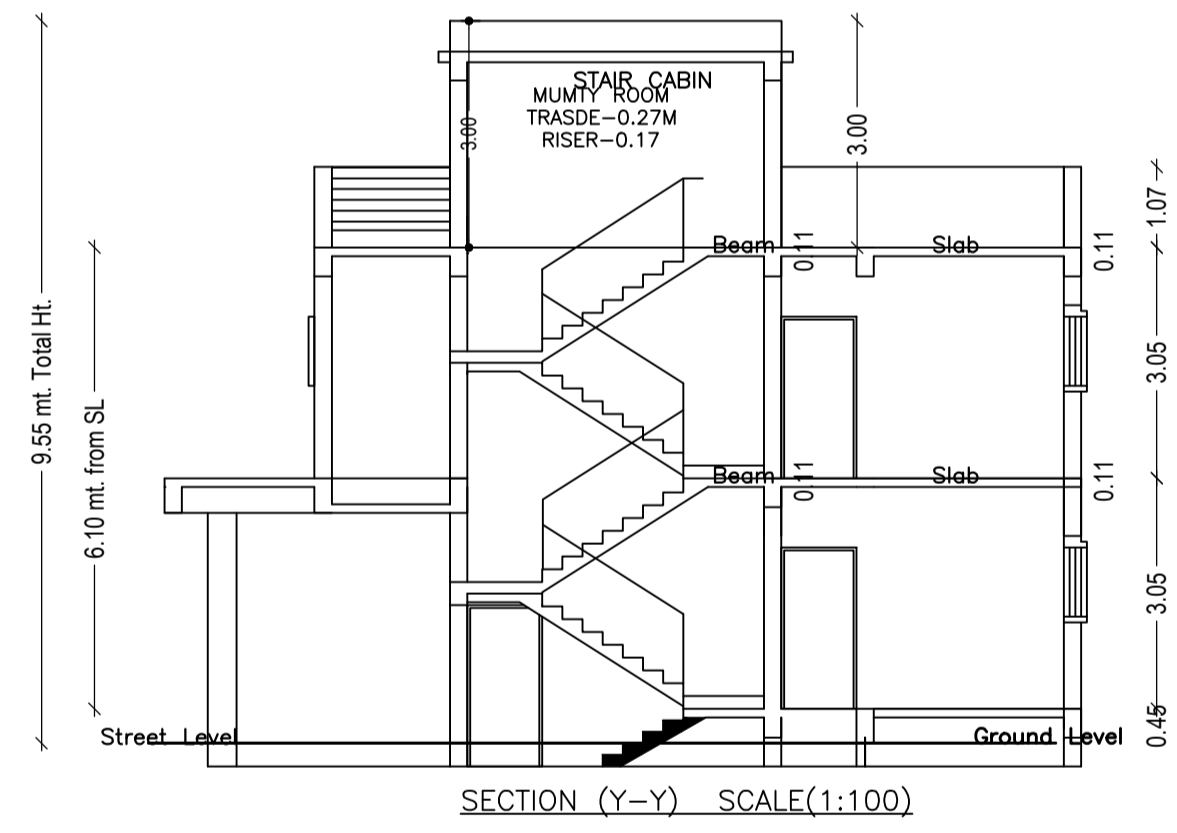
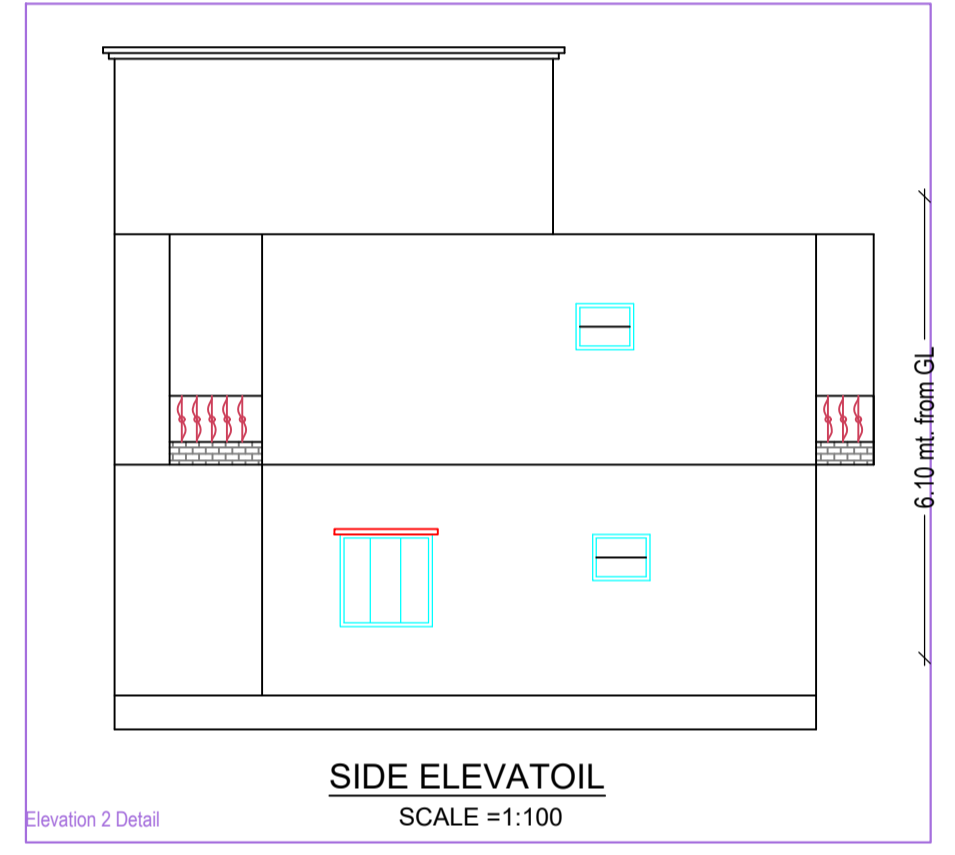
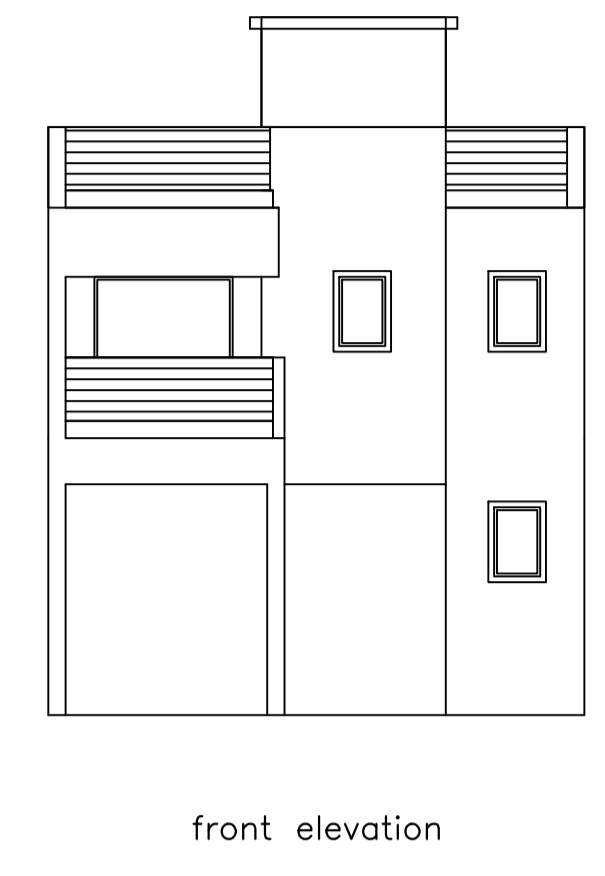
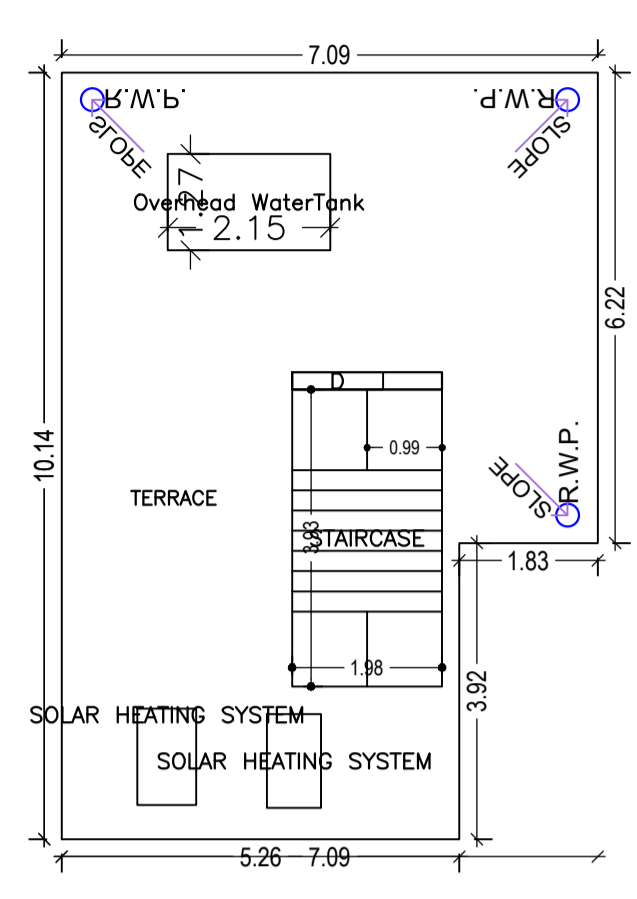
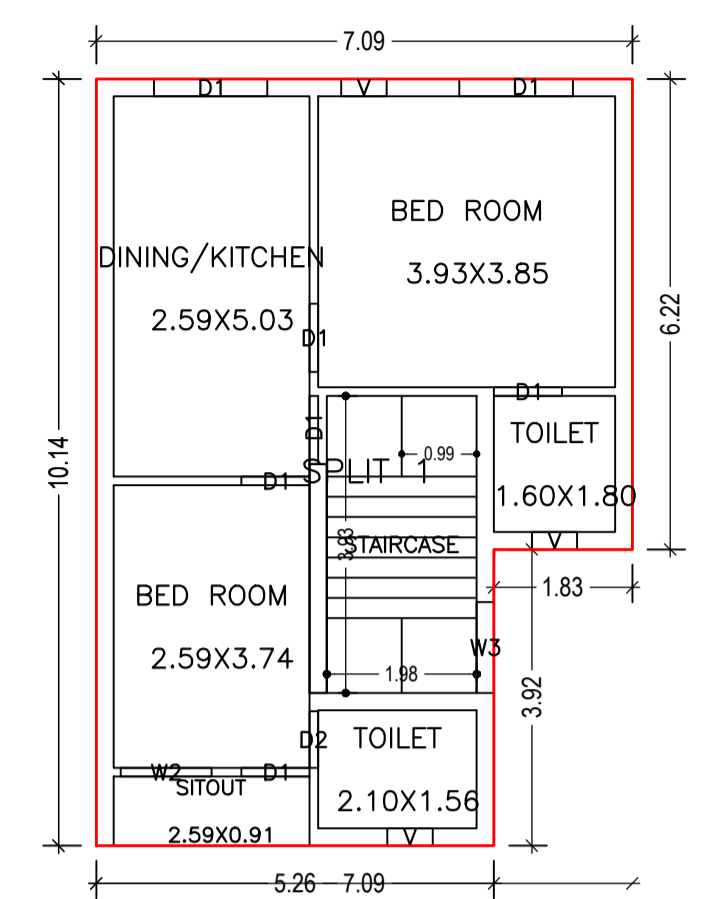
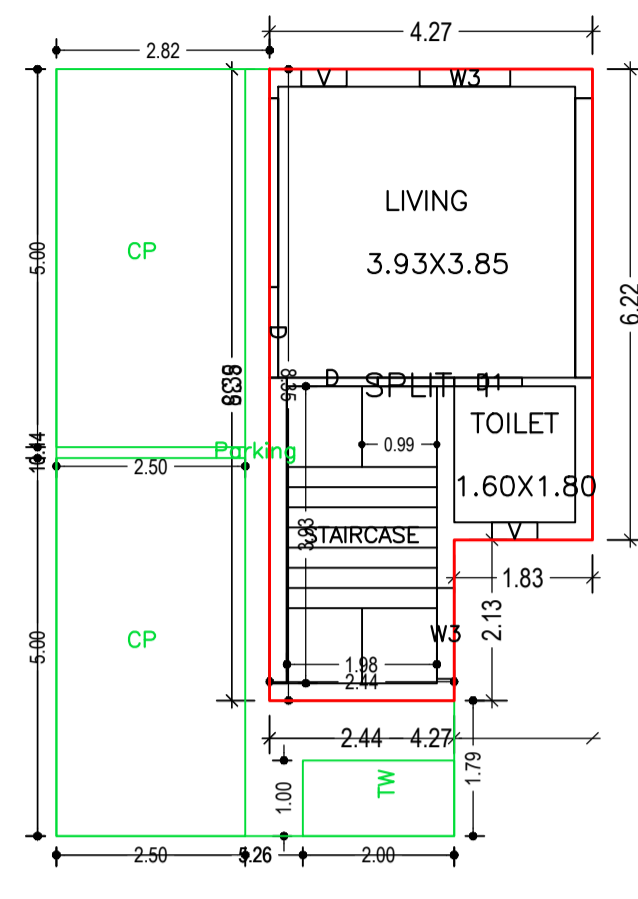
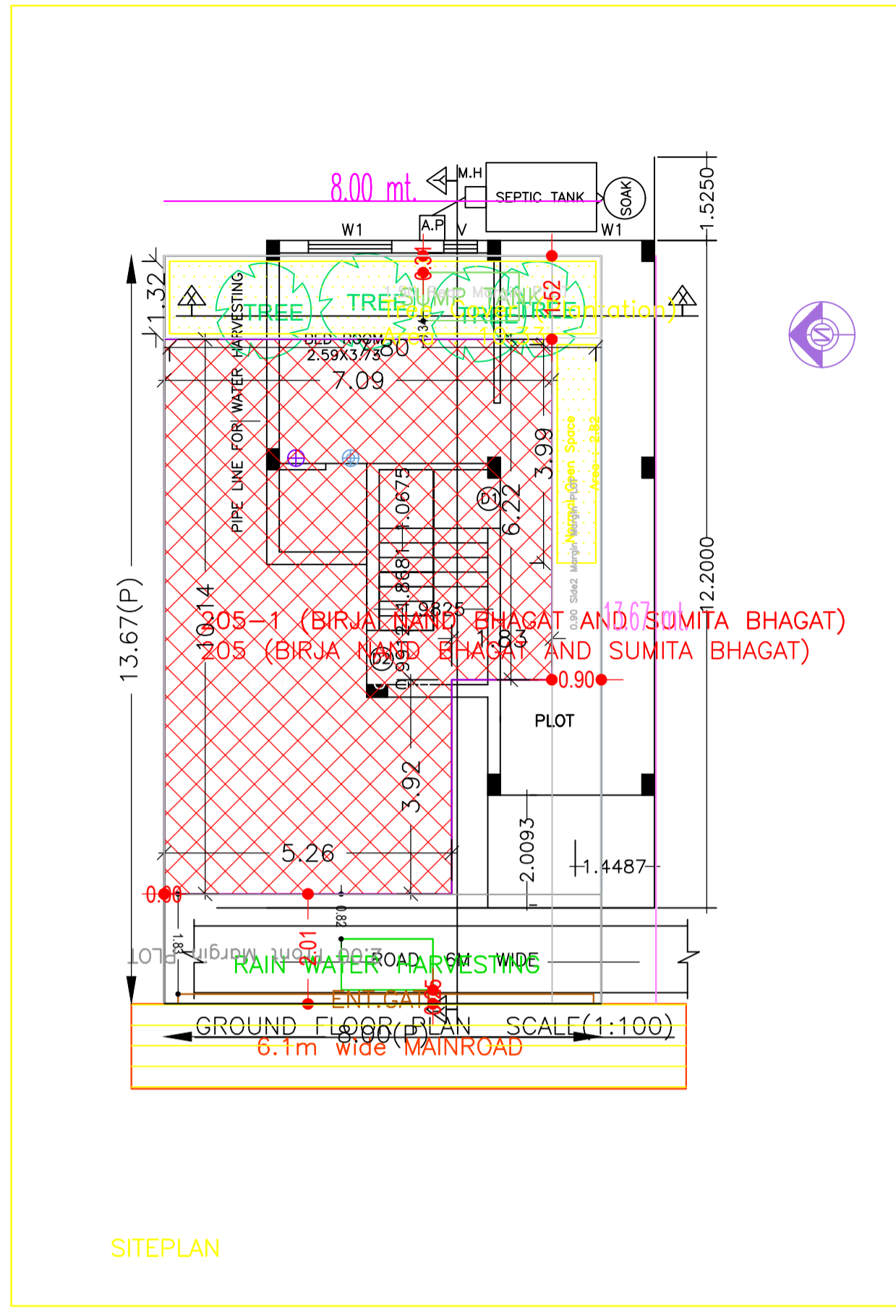

AREA STATEMENT	VERSION NO. : 1.0.59	
ADITYAPUR MUNICIPAL CORPORATION	VERSION DATE: 16/10/2020	
PROJECT DETAIL:		
Region: JHARKHAND URBAN LOCAL BODIES	Plot Use: Residential	
District: EAST SINGHBHUM	Plot SubUse: Bungalow/ Dwelling / Non Apartment	
Authority: ADITYAPUR MUNICIPAL CORPORATION	PlotNearby/ReligiousStructure: NA	
Inward No: AMC/BP/0001/W22/2021	Plot/SubPlot No: 1213	
Application Type: General Proposal	North: -	
Project Type: Building Permission	South: -	
Nature of Development: New	East: Plot No. - 1213(P) 1210(p)	
Location of Development Area: Old Area	West: Road Width - 6.1	
AREA DETAILS:		
AREA OF PLOT (Minimum)	(A)	SQ.MT.
NET AREA OF PLOT(Gross Plot Area - Deduction from Gross Plot area)	(A-Deductions)	109.35
Deduction for Balance Plot Area(from Gross Plot Area)		
Common Plot		13.15
Total		13.15
BALANCE AREA OF PLOT(Net Plot Area - Recreational/Amenity space)	(A-Deductions)	96.20
PLOT AREA FOR COVERAGE(Net Plot Area)	(A-Deductions)	109.35
Plot Area for FAR (Net Plot Area + RoadWidening Area)	(A-Deductions)	109.35
COVERAGE CHECK		
Permissible Coverage area (70.00 %)		76.54
Proposed Coverage Area (59.21 %)		64.74
Total Prop. Coverage Area (59.21 %)		64.74
Balance coverage area (10.79 %)		11.80
FAR CHECK		
Perm. FAR Area (2.50)		273.38
Total Perm. FAR area		273.38
Residential FAR		96.51
Proposed FAR Area		96.51
Total Proposed FAR Area		96.51
Consumed FAR (Factor)		0.88
Balance FAR Area		176.87
BUILT UP AREA CHECK		
Total Proposed BuiltUp Area		129.49
ARCHITECT (Regd)	Abhishek Tewari	
ENGINEER (Regd)		
SUPERVISOR (Regd)		
OWNER (Regd)	BRIJA NAND BHAGAT AND SUMITA BHAGAT	
DEVELOPMENT AUTHORITY	LOCAL BODY	

COLOR INDEX	
PLOT BOUNDARY	Black
ABUTTING ROAD	Red
PROPOSED CONSTRUCTION	Green
COMMON PLOT	Yellow
ROAD WIDENING AREA	Blue
EXISTING (To be retained)	Light Blue
EXISTING (To be demolished)	Dark Blue

Buildingwise Floor FAR Details				
Floor Name	Building Name		Total	
	Proposed Built Up Area (Sq.mt.)	Proposed FAR Area (Sq.mt.)	Total Proposed Built Up Area (Sq.mt.)	Total FAR Area (Sq.mt.)
Ground Floor	64.74	31.76	64.74	31.76
First Floor	64.75	64.75	64.75	64.75
Terrace Floor	0.00	0.00	0.00	0.00
Total :	129.49	96.51	129.49	96.51

Building USE/SUBUSE Details			
Building Name	Building Use	Building SubUse	Building Structure
205 (BIRJA NAND BHAGAT AND SUMITA BHAGAT)	Residential	Bungalow/ Dwelling / Non Apartment	Non-Highrise

FAR & Tenement Details (Table 4c-1)							
Building	No. of Same Bldg	Total Built Up Area (Sq.mt.)	Deductions (Area in Sq.mt.)	Proposed FAR Area (Sq.mt.)	Total FAR Area (Sq.mt.)	Total Consumed Additional FAR Area (Sq.mt.)	Trmnt (No.)
205 (BIRJA NAND BHAGAT AND SUMITA BHAGAT)	1	129.49	32.98	96.51	96.51	96.51	01
Grand Total :	1	129.49	32.98	96.51	96.51	96.51	01

SCHEDULE OF DOOR:				
BUILDING NAME	NAME	LENGTH	HEIGHT	NOS
205 (BIRJA NAND BHAGAT AND SUMITA BHAGAT)	D2	0.75	2.10	01
205 (BIRJA NAND BHAGAT AND SUMITA BHAGAT)	D1	0.90	2.10	06
205 (BIRJA NAND BHAGAT AND SUMITA BHAGAT)	D	1.20	2.10	02

SCHEDULE OF WINDOW/VENTILATION:				
BUILDING NAME	NAME	LENGTH	HEIGHT	NOS
205 (BIRJA NAND BHAGAT AND SUMITA BHAGAT)	V	0.60	0.90	05
205 (BIRJA NAND BHAGAT AND SUMITA BHAGAT)	W2	1.20	1.50	01
205 (BIRJA NAND BHAGAT AND SUMITA BHAGAT)	W3	1.20	1.50	03
205 (BIRJA NAND BHAGAT AND SUMITA BHAGAT)	D1	1.50	1.20	02

Building :205 (BIRJA NAND BHAGAT AND SUMITA BHAGAT)						
Floor Name	Total Built Up Area (Sq.mt.)	Deductions (Area in Sq.mt.)	Proposed FAR Area (Sq.mt.)	Total FAR Area (Sq.mt.)	Total Consumed Additional FAR Area (Sq.mt.)	Trmnt (No.)
Ground Floor	64.74	32.98	31.76	31.76	31.76	01
First Floor	64.75	0.00	64.75	64.75	64.75	00
Terrace Floor	0.00	0.00	0.00	0.00	0.00	00
Total :	129.49	32.98	96.51	96.51	96.51	01
Total Number of Same Buildings :	1					
Total :	129.49	32.98	96.51	96.51	96.51	01

UnitBUA Table for Building :205 (BIRJA NAND BHAGAT AND SUMITA BHAGAT)						
FLOOR	Name	UnitBUA Type	UnitBUA Area	Carpet Area	No. of Rooms	No. of Tenement
FIRST FLOOR PLAN	SPLIT 1	FLAT	0.00	0.00	6	0
GROUND FLOOR PLAN	SPLIT 1	FLAT	84.30	83.49	2	1
Total:	-	-	84.30	83.49	8	1

LTP NAME AND SIGNATURE	STRUCTURAL ENG'S NAME AND SIGNATURE	BUILDER NAME AND SIGNATURE	DIGITAL SIGNATURE
Abhishek Tewari AMC/ARC/0026/2016			

Proposal Basic Information	
Proposal File No.	AMC/BP/0001/W22/2021
Owner Name	BRIJA NAND BHAGAT AND SUMITA BHAGAT
Khata No	222
Plot No	1213
Village Name	ASANGI
Use	Residential
SubUse	Bungalow/ Dwelling / Non Apartment

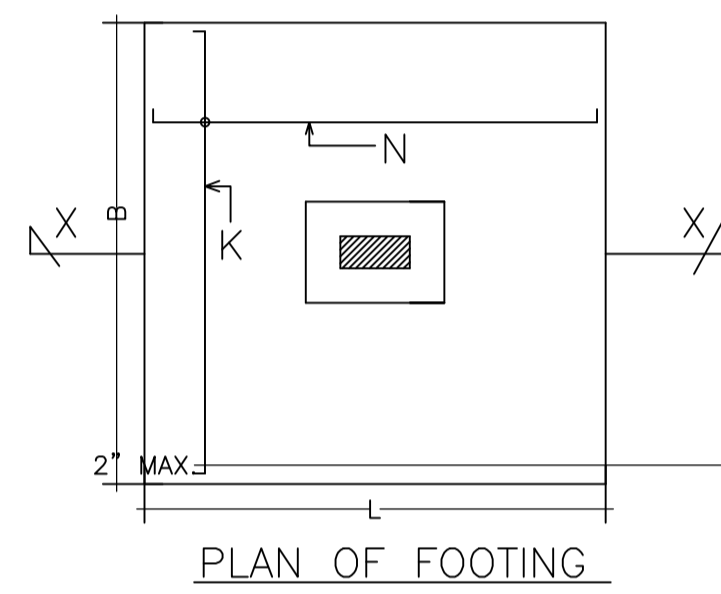
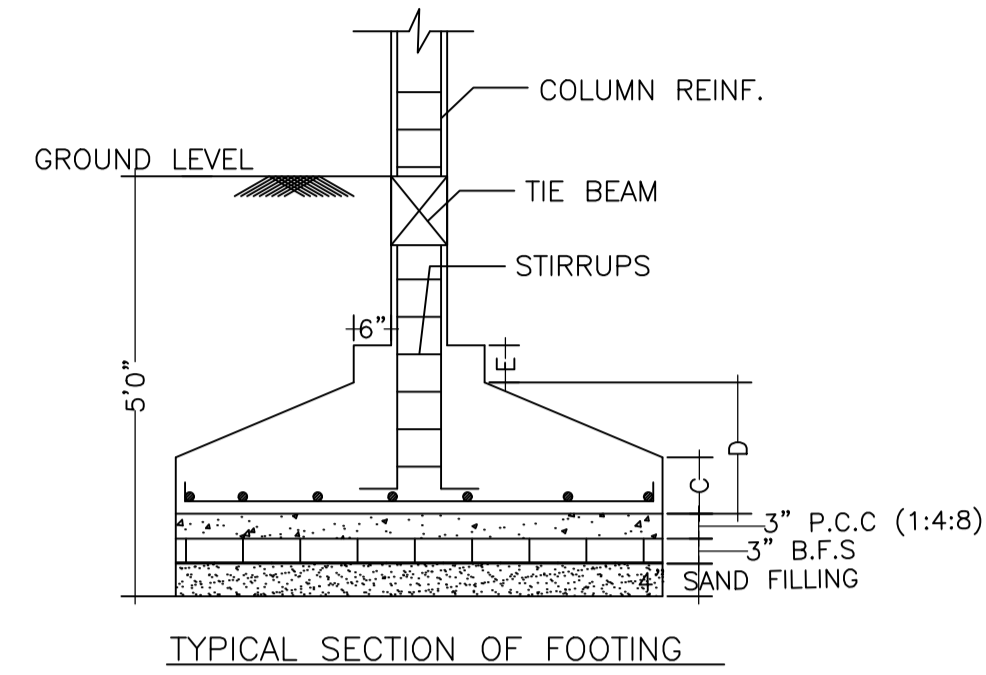
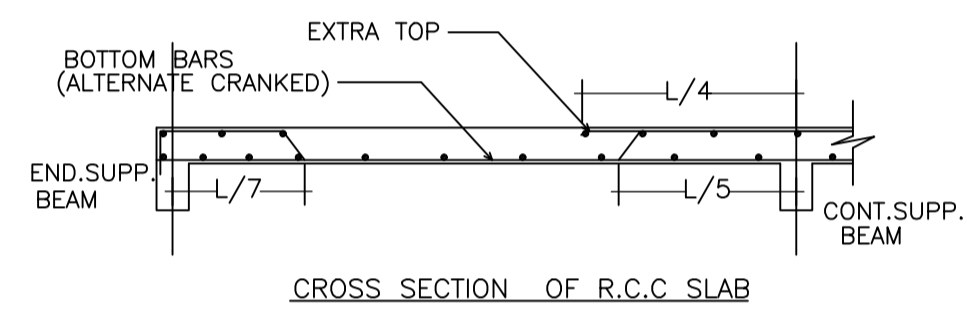
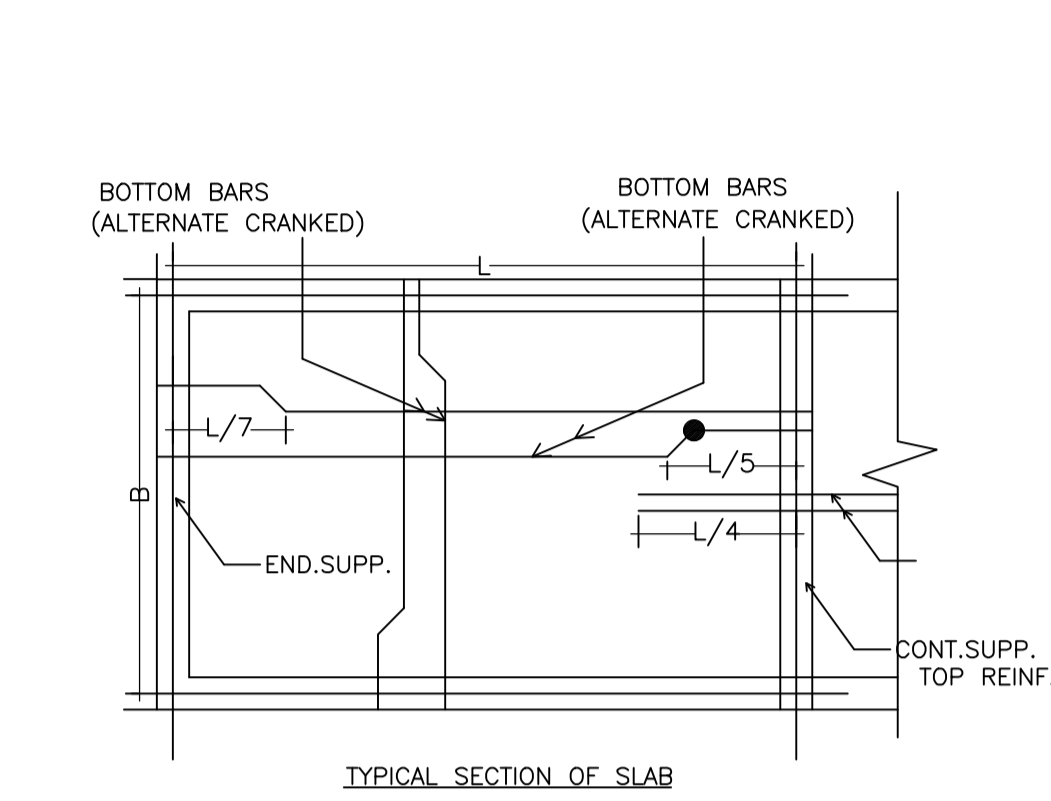

COLUMN SIZE	B	L	C1	C2	C3
	9"	12"	9"	15"	9"
			M20	M20	M20
CONCRETE MIX SECTION WITH MAIN STEEL			6 - 12 mm. Tor	4 - 12 mm. Tor 2 - 16 mm. Tor	6 - 16 mm. Tor
LINKS			6 mm. @ 8" C/C		

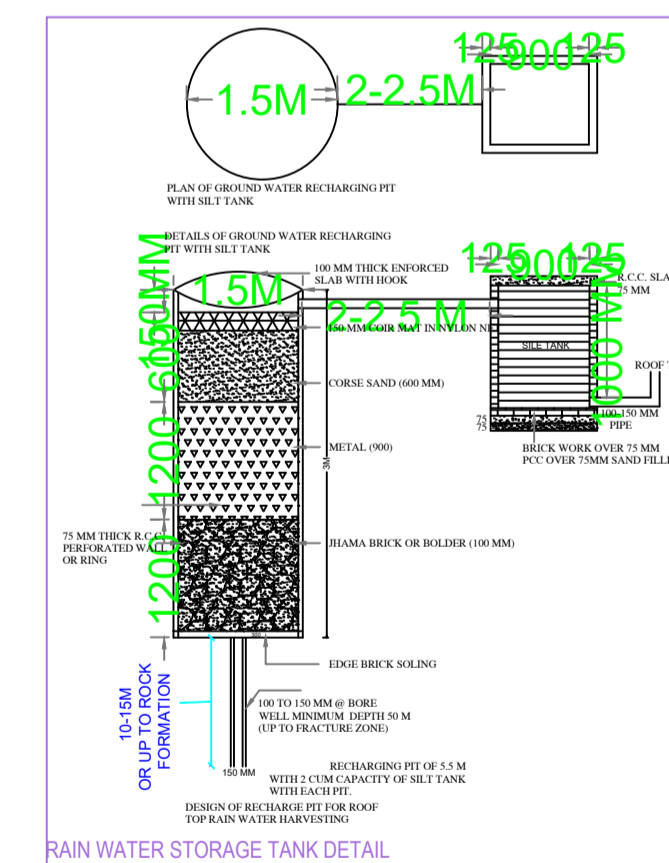
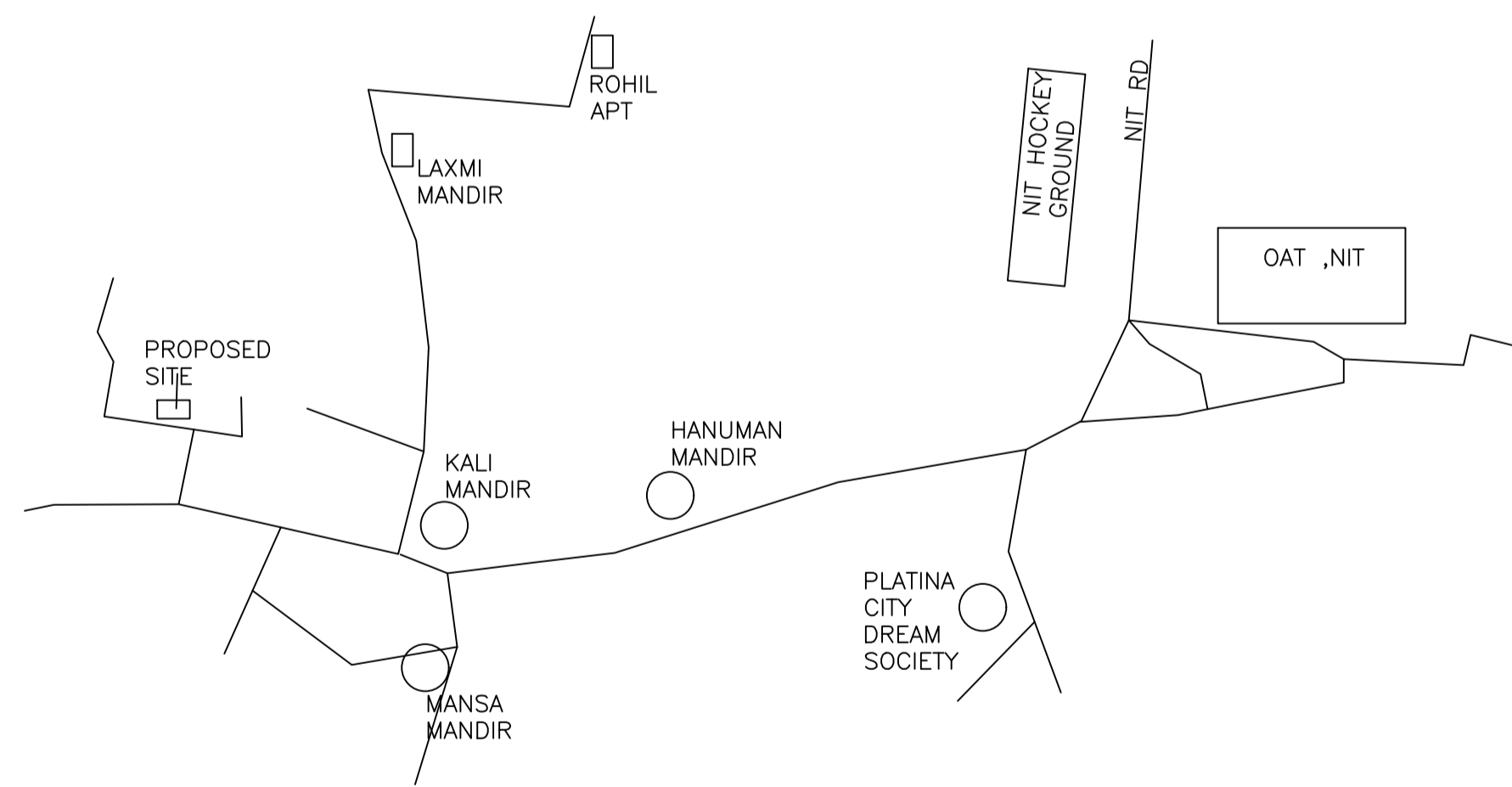
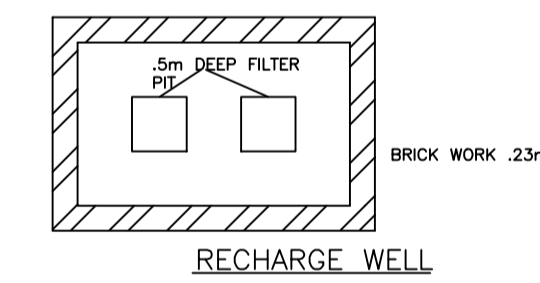
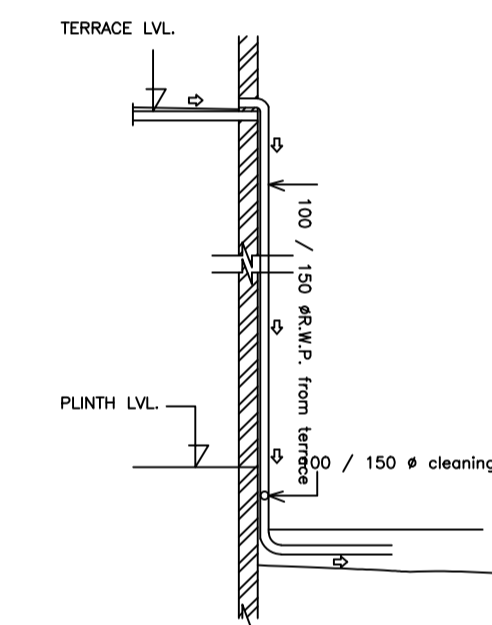
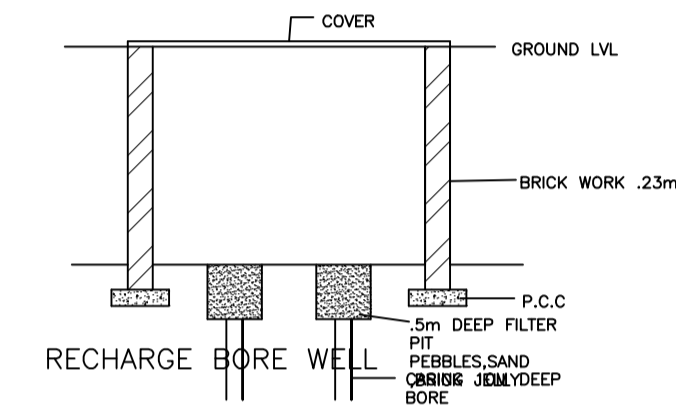
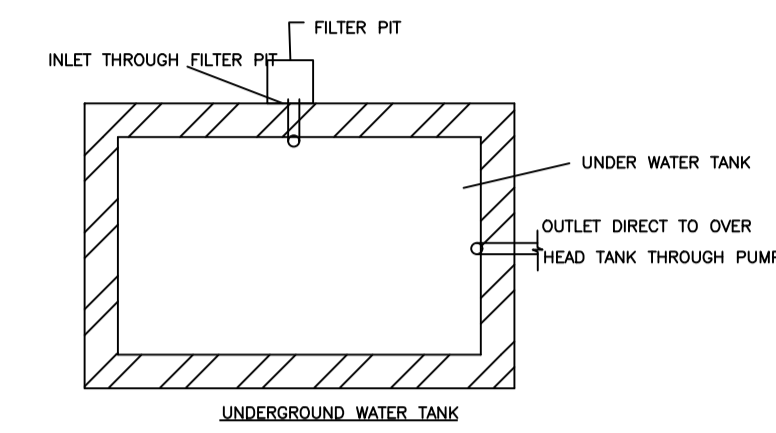
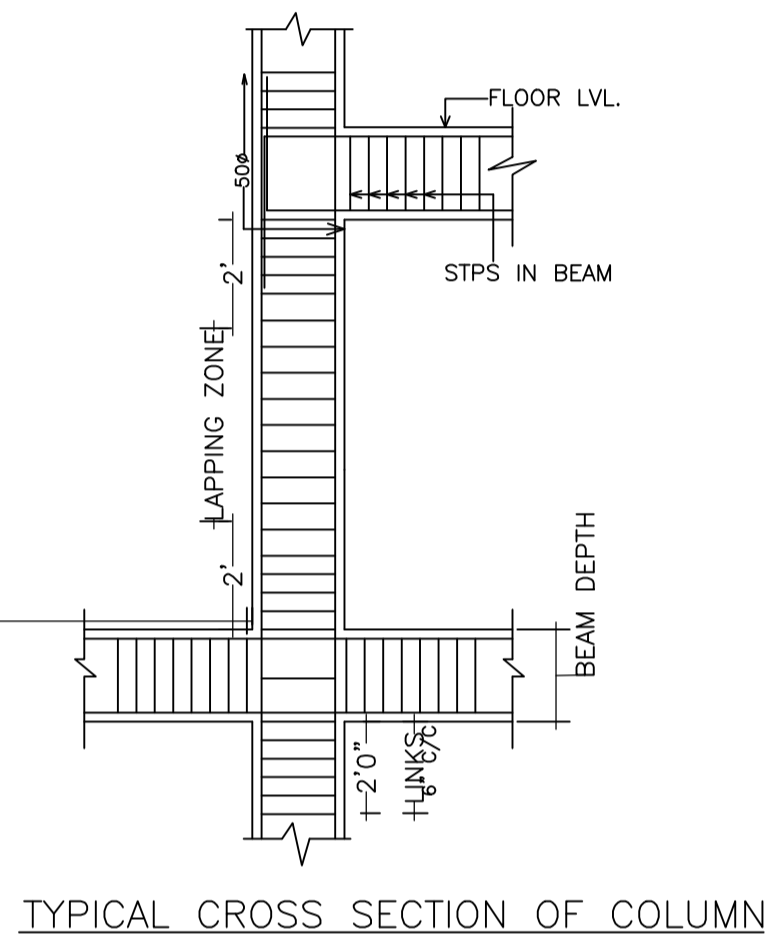

LTP NAME AND SIGNATURE	STRUCTURAL ENG'S NAME AND SIGNATURE	BUILDER NAME AND SIGNATURE	DIGITAL SIGNATURE
Abhishek Tewari AMC/ARC/0028/2016			