

NOTIFICATION	DISCRPTION
	INSPECTION CHAMBER
	RAIN WATER PIPE
	OVERFLOW OUTLET FOR RECHARGE PIT
	OVERFLOW OUTLET FOR SEPTIC TANK
	SOAK PIT

DRAIN PIPELINE LAYOUT

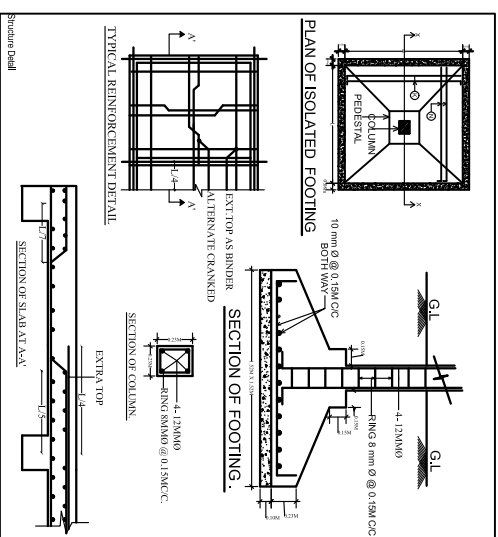

SCHEDULE OF DOOR & WINDOW				
TYPE	WIDTH	HT.	SILL	DESCRIPTION
D	1.07	2.13	0	WOODEN FLUSH DOOR
D1	0.99	2.13	0	WOODEN FLUSH DOOR
D2	0.76	2.13	0	WOODEN FLUSH DOOR
W	1.52	1.52	0.61	GLAZED WINDOW
W1	1.22	1.52	0.61	GLAZED WINDOW
W2	0.91	1.52	0.61	GLAZED WINDOW
V	0.76	0.61	1.52	GLAZED VENTILATOR

COLCULATION FOR WATER TANK
 CONSIDERING FOR 15 PERSONS = 15 X 135 = 2025 LTS.
 APPROVED = 5,000 LTS.

COLCULATION FOR SEPTIC TANK
 CONSIDERING FOR 15 PERSONS = 15 X 0.83 = 1.245 CUM
 APPROVED = 2.78X1.06X1.5 = 4.4202 CUM

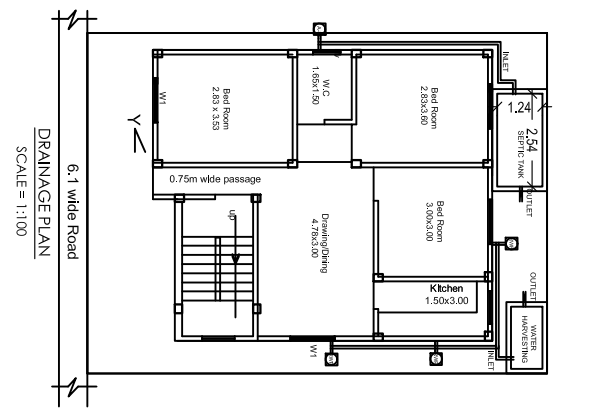
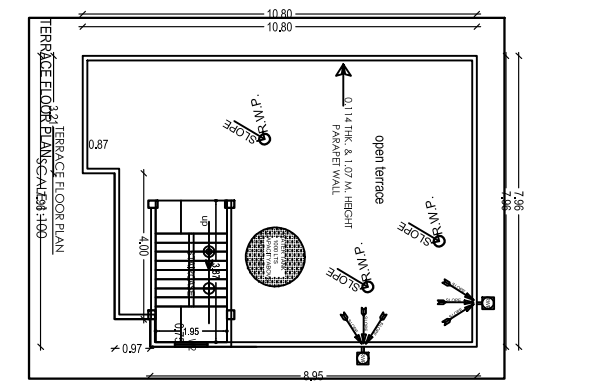
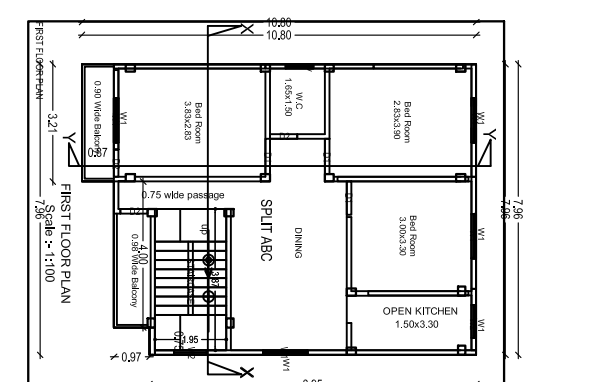
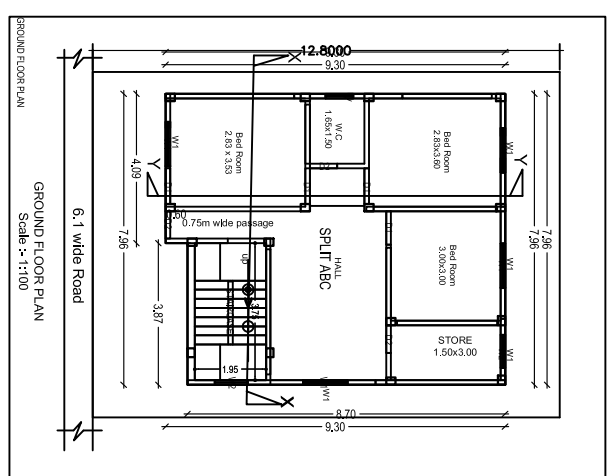
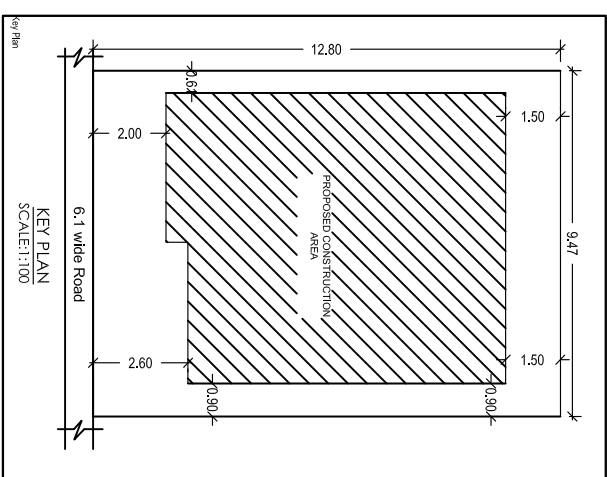
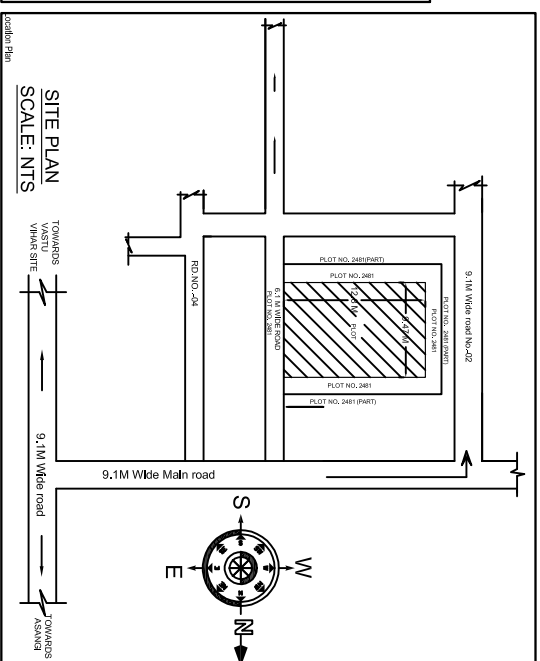
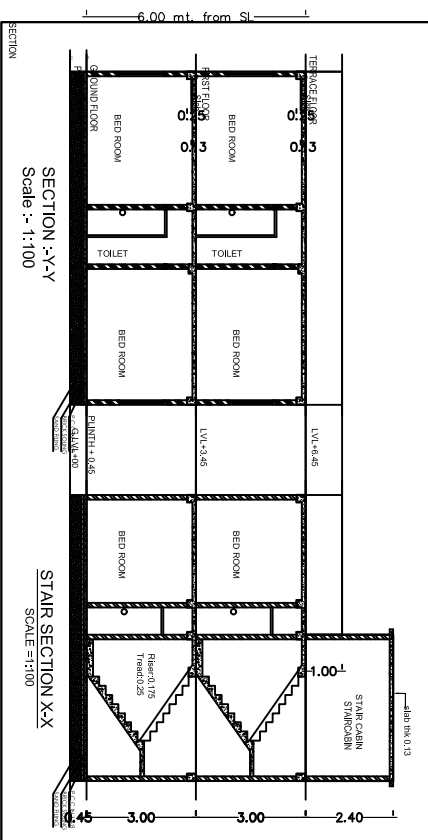
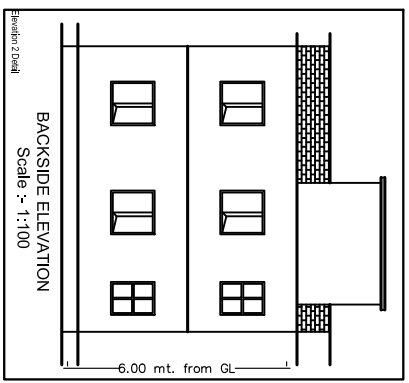
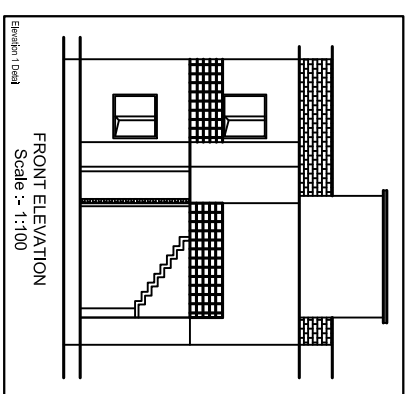

PROPOSED RESIDENTIAL BUILDING PLAN FOR
 LAND OWNER: PRIVATE LIMITED
 ITS REPRESENTATIVE: MR. PRABHAT KUMAR SINHA

DETAILS OF PLOT :-
 PLOT NO:-456(OLD), 2481(NEW)
 KHATA NO :- 48(OLD), 110(NEW)
 MOUZA :- ASANGI
 WARD NO :- 22
 THANA NO:- 131, P.S:- RITADITYAPUR
 DISTRICT :- SERAIKELA, JHARKHAND

CONTENTS :-
 * SITE PLAN
 * GROUND FLOOR PLAN
 * FIRST FLOOR PLAN
 * SECOND FLOOR PLAN
 * DRAINAGE PLAN
 * GROUND COVERAGE
 * CALCULATION
 * F.A.R CALCULATION

TERRACE FLOOR PLAN
 FRONT ELEVATION
 SIDE ELEVATION
 SECTION 'X-X'
 SECTION 'Y-Y'
 LOCATION MAP
 PART MOUZA PLAN

SH. NO 1/1

PLANNER