

KEY PLAN
SCALE:1:100

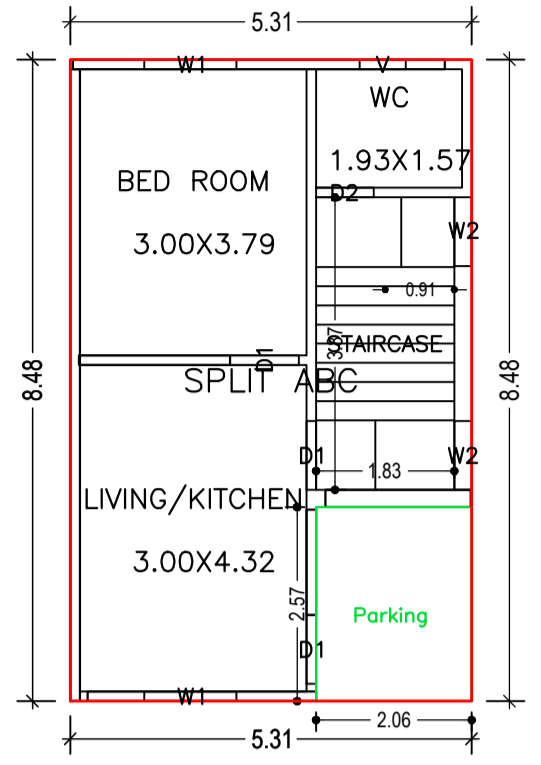

GROUND FLOOR PLAN
(Proposed)
SCALE:1:100

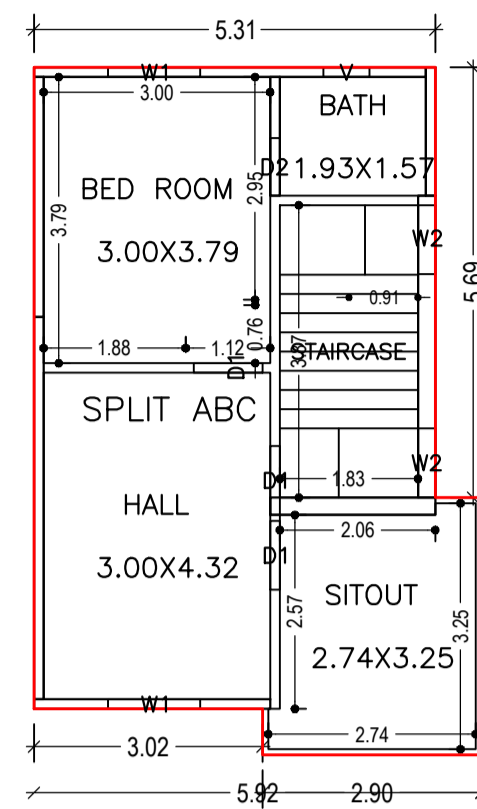

FIRST FLOOR PLAN
(Proposed)
SCALE:1:100

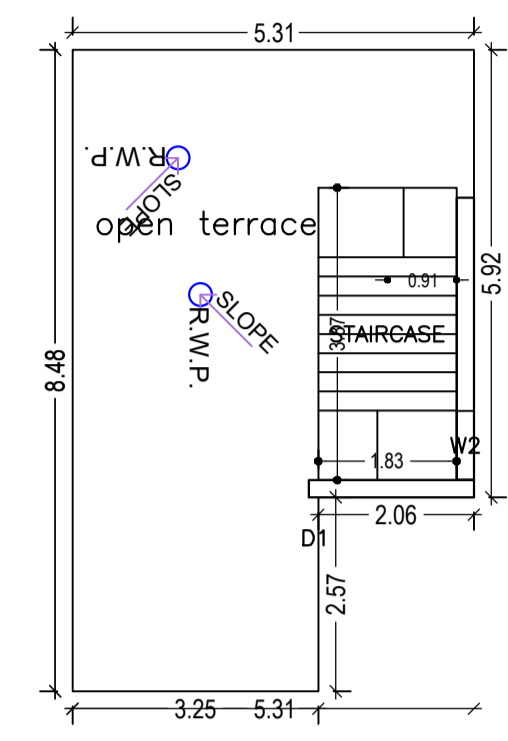

TERRACE FLOOR PLAN
(Proposed)
SCALE:1:100

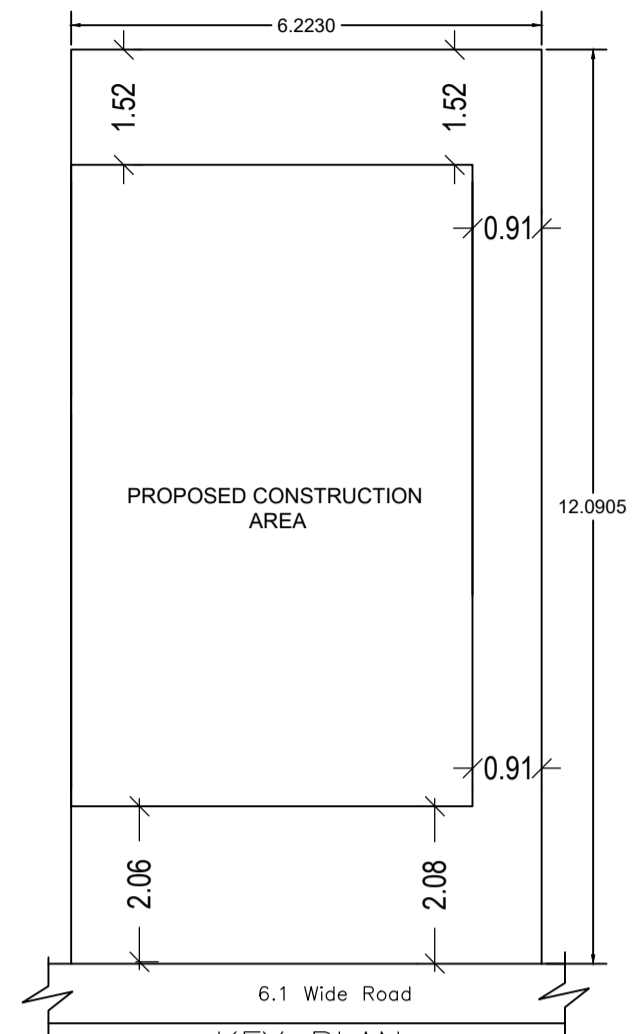

KEY PLAN
SCALE:1:100

SCHEDULE OF DOOR:

BUILDING NAME	NAME	LENGTH	HEIGHT	NOS
A(TBCPL)	D2	0.76	2.13	02
A(TBCPL)	D1	0.91	2.13	06

SCHEDULE OF WINDOW/VENTILATION:

BUILDING NAME	NAME	LENGTH	HEIGHT	NOS
A(TBCPL)	V	0.61	0.61	02
A(TBCPL)	W2	0.91	1.22	05
A(TBCPL)	W1	1.22	1.22	04

Proposal Basic Information

Proposal File No.	AMC/BP/0093/W22/2021
Owner Name	TECHNOCULTURE BUILDING CENTRE PRIVATE LIMITED
Khata No	190/403
Plot No	429/2401
Village Name	ASANGI
Use	Residential
SubUse	Bungalow/ Dwelling / Non Apartment

AREA STATEMENT
ADITYAPUR MUNICIPAL CORPORATION

VERSION NO.: 1.0.62
VERSION DATE: 16/10/2020

PROJECT DETAIL:
Region: JHARKHAND URBAN LOCAL BODIES
District: EAST SINGHBHUM
Authority: ADITYAPUR MUNICIPAL CORPORATION
Inward No: AMC/BP/0093/W22/2021
Application Type: General Proposal
Project Type: Building Permission
Nature of Development: New
Location of Development Area: Old Area

Plot Use: Residential
Plot SubUse: Bungalow/ Dwelling / Non Apartment
Plot/Nearby/Religious/Structure: NA
North: Plot No. - 429/2401
South: Plot No. - 429/4201
East: Plot No. - boundary
West: Road Width - 6.1

AREA DETAILS:		SQ.MT.
AREA OF PLOT (Minimum)	(A)	75.24
NET AREA OF PLOT (Gross Plot Area - Deduction from Gross Plot area)	(A-Deductions)	75.24
Deduction for Balance Plot Area (from Gross Plot Area)		
Common Plot		5.30
Total		5.30
BALANCE AREA OF PLOT (Net Plot Area - Recreational/Amenity space)	(A-Deductions)	69.94
PLOT AREA FOR COVERAGE (Net Plot Area)	(A-Deductions)	75.24
Plot Area for FAR (Net Plot Area + Road Widening Area)	(A-Deductions)	75.24
COVERAGE CHECK		
Permissible Coverage area (70.00 %)		52.67
Proposed Coverage Area (59.86 %)		45.04
Total Prop. Coverage Area (59.86 %)		45.04
Balance coverage area (10.14 %)		7.63
FAR CHECK		
Perm. FAR Area (2.50)		188.10
Total Perm. FAR area		188.10
Residential FAR		93.54
Proposed FAR Area		93.54
Total Proposed FAR Area		93.54
Consumed FAR (Factor)		1.24
Balance FAR Area		94.56
BUILT UP AREA CHECK		
Total Proposed BuiltUp Area		93.55
ARCHITECT (Regd)		MOHAMMAD BELAL NASIR
ENGINEER (Regd)		
SUPERVISOR (Regd)		
OWNER (Regd)		TECHNOCULTURE BUILDING CENTRE PRIVATE LIMITED
DEVELOPMENT AUTHORITY		LOCAL BODY

site Plan

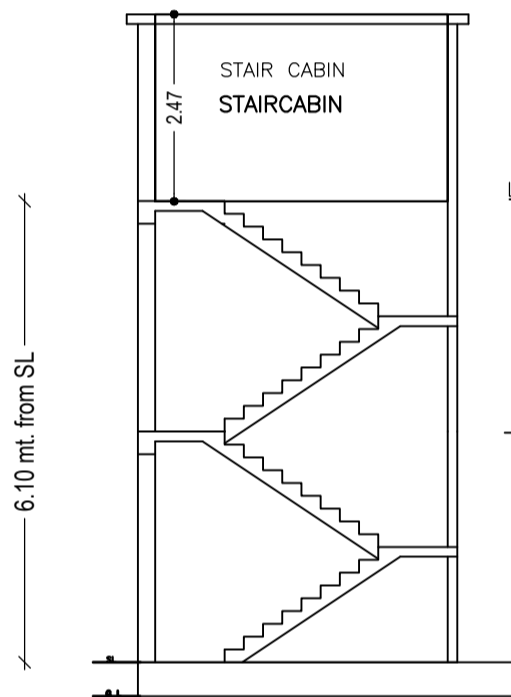

SECTION: X-X
(SCALE 1:100)

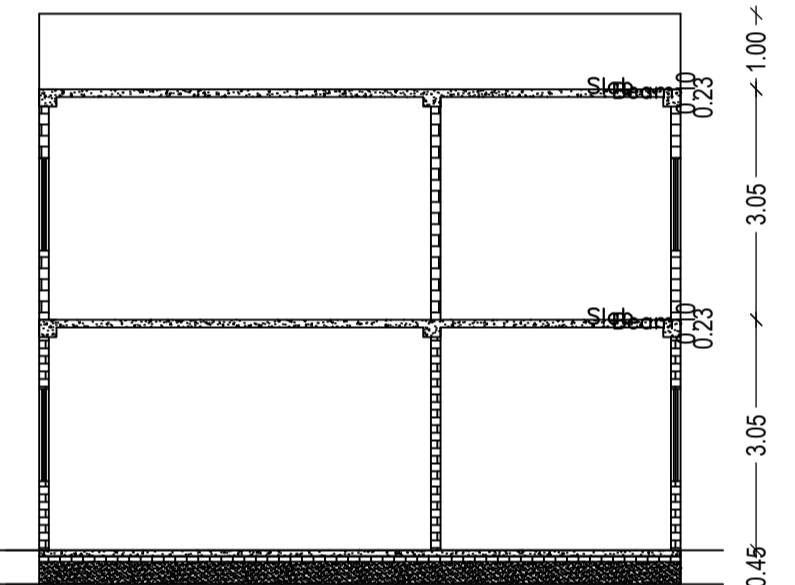

SECTION: Y-Y
(SCALE 1:100)

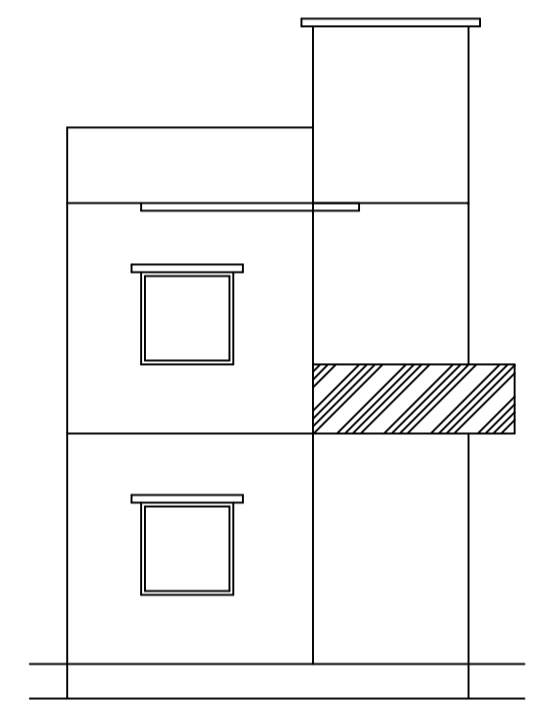

FRONT ELEVATION
SCALE =1:100

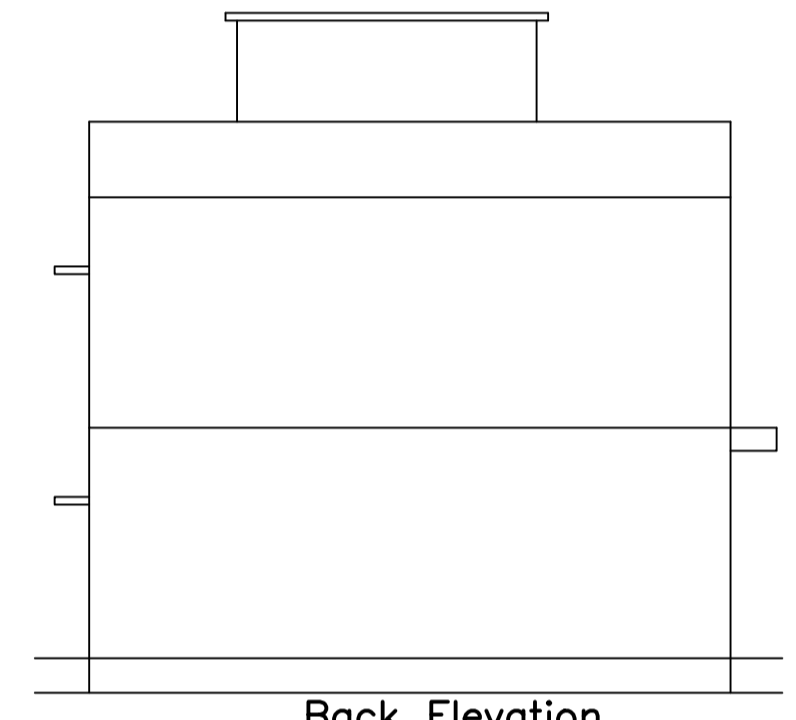

Back Elevation
SCALE 1:100

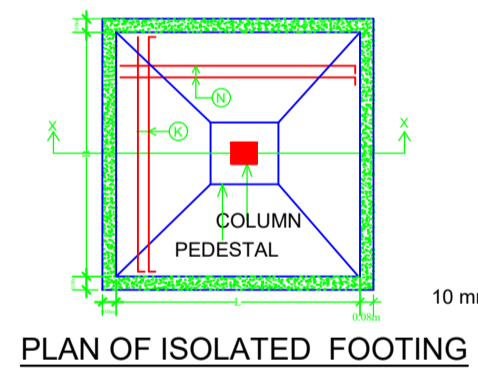
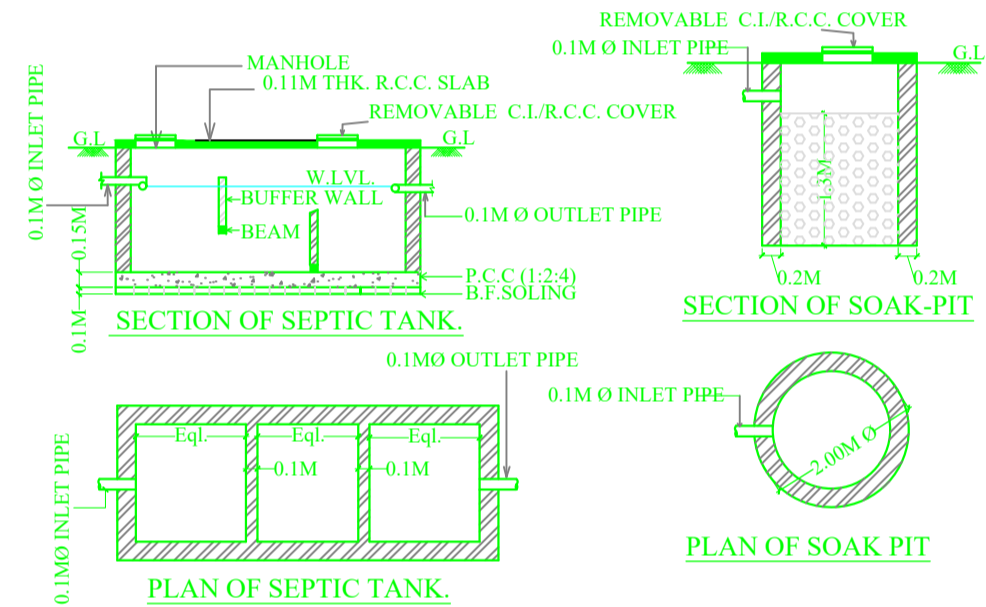

PLAN OF ISOLATED FOOTING

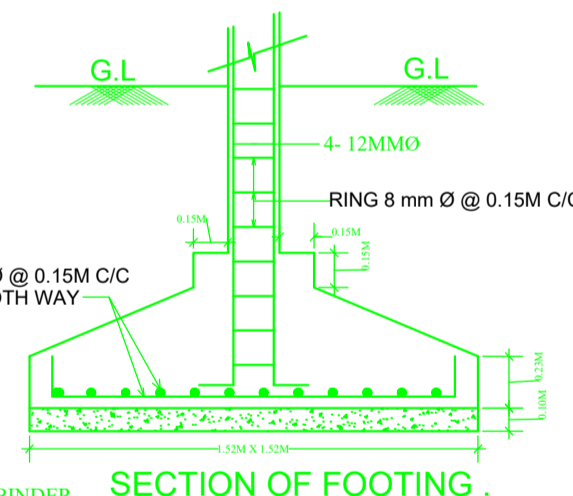

SECTION OF FOOTING

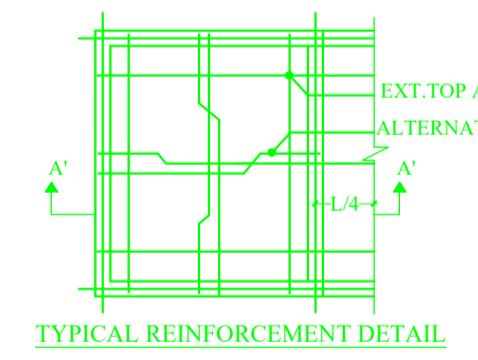

TYPICAL REINFORCEMENT DETAIL

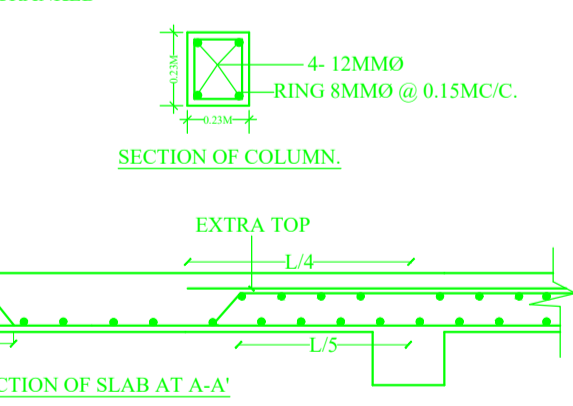

SECTION OF COLUMN

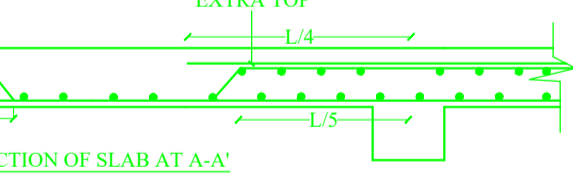

SECTION OF SLAB AT A-A'

COLOR INDEX

PLOT BOUNDARY	Black
ABUTTING ROAD	Green
PROPOSED CONSTRUCTION	Red
COMMON PLOT	Yellow
ROAD WIDENING AREA	Blue
EXISTING (To be retained)	Light Blue
EXISTING (To be demolished)	Dark Blue

Buildingwise Floor FAR Details

Floor Name	Building Name A(TBCPL)		Total	
	Proposed Built Up Area (Sq.mt.)	Proposed FAR Area (Sq.mt.)	Total Proposed Built Up Area (Sq.mt.)	Total FAR Area (Sq.mt.)
Ground Floor	45.04	45.04	45.04	45.04
First Floor	48.51	48.51	48.51	48.51
Terrace Floor	0.00	0.00	0.00	0.00
Total :	93.55	93.55	93.55	93.55

Building USE/SUBUSE Details

Building Name	Building Use	Building SubUse	Building Structure
A(TBCPL)	Residential	Residential Bldg/Apartment	Non-Highrise

FAR & Tenement Details (Table 4c-1)

Building	No. of Same Bldg	Total Built Up Area (Sq.mt.)	Proposed FAR Area (Sq.mt.)	Total FAR Area (Sq.mt.)	Total Consumed Additional FAR Area (Sq.mt.)	Trnmt (No.)
A(TBCPL)	1	93.55	93.55	93.55	93.55	01
Grand Total :	1	93.55	93.55	93.55	93.55	01

UnitBUA Table for Building :A(TBCPL)

FLOOR	Name	UnitBUA Type	UnitBUA Area	Carpet Area	No. of Rooms	No. of Tenement
GROUND FLOOR PLAN	SPLIT ABC	FLAT	87.71	80.84	3	1
FIRST FLOOR PLAN	SPLIT ABC	FLAT	0.00	0.00	4	0
Total:	-	-	87.71	80.84	7	1

Building :A(TBCPL)

Floor Name	Total Built Up Area (Sq.mt.)	Proposed FAR Area (Sq.mt.)	Total FAR Area (Sq.mt.)	Total Consumed Additional FAR Area (Sq.mt.)	Trnmt (No.)
Ground Floor	45.04	45.04	45.04	45.04	01
First Floor	48.51	48.51	48.51	48.51	00
Terrace Floor	0.00	0.00	0.00	0.00	00
Total :	93.55	93.55	93.55	93.55	01
Total Number of Same Buildings :	1				
Total :	93.55	93.55	93.55	93.55	01

LTP NAME AND SIGNATURE	STRUCTURAL ENG'S NAME AND SIGNATURE	BUILDER NAME AND SIGNATURE	DIGITAL SIGNATURE
MOHAMMAD BELAL NASIR AMC/ENG/0015/2017			