

Project Title - RESIDENTIAL

PROPERTY DETAILS	
Plot No.	152/3
Area	47.98 Sq. Mts
Zone	UR
Sub-Zone	UR-1
Block	B-1
Section	S-1
Project Name	RESIDENTIAL
Client	ABC
Contract No.	123/45
Issue No.	01
Issue Date	2023-10-27

MATERIALS	
Concrete (M20)	M20
Reinforcement (Fe500)	Fe500
Brick	Standard
Plaster (1:3:6)	1:3:6
Paint (Exterior)	White
Paint (Interior)	White
Flooring (Tiles)	600x600

COLOR INDEX	
WALLS	White
FLOORS	Light Grey
ROOFING	Dark Grey

PARKING CALCULATION		
Room No.	Room Size	Room Area
1	10.00 x 10.00	100.00
2	12.00 x 12.00	144.00
3	8.00 x 8.00	64.00
4	15.00 x 15.00	225.00
5	10.00 x 12.00	120.00
6	12.00 x 10.00	120.00
7	8.00 x 10.00	80.00
8	10.00 x 12.00	120.00
9	12.00 x 15.00	180.00
10	15.00 x 12.00	180.00
11	10.00 x 15.00	150.00
12	12.00 x 10.00	120.00
13	8.00 x 12.00	96.00
14	12.00 x 10.00	120.00
15	10.00 x 10.00	100.00
16	15.00 x 10.00	150.00
17	10.00 x 15.00	150.00
18	12.00 x 12.00	144.00
19	15.00 x 15.00	225.00
20	10.00 x 12.00	120.00
21	12.00 x 15.00	180.00
22	15.00 x 12.00	180.00
23	10.00 x 15.00	150.00
24	12.00 x 10.00	120.00
25	8.00 x 12.00	96.00
26	12.00 x 10.00	120.00
27	10.00 x 10.00	100.00
28	15.00 x 10.00	150.00
29	10.00 x 15.00	150.00
30	12.00 x 12.00	144.00
31	15.00 x 15.00	225.00
32	10.00 x 12.00	120.00
33	12.00 x 15.00	180.00
34	15.00 x 12.00	180.00
35	10.00 x 15.00	150.00
36	12.00 x 10.00	120.00
37	8.00 x 12.00	96.00
38	12.00 x 10.00	120.00
39	10.00 x 10.00	100.00
40	15.00 x 10.00	150.00
41	10.00 x 15.00	150.00
42	12.00 x 12.00	144.00
43	15.00 x 15.00	225.00
44	10.00 x 12.00	120.00
45	12.00 x 15.00	180.00
46	15.00 x 12.00	180.00
47	10.00 x 15.00	150.00
48	12.00 x 10.00	120.00
49	8.00 x 12.00	96.00
50	12.00 x 10.00	120.00
51	10.00 x 10.00	100.00
52	15.00 x 10.00	150.00
53	10.00 x 15.00	150.00
54	12.00 x 12.00	144.00
55	15.00 x 15.00	225.00
56	10.00 x 12.00	120.00
57	12.00 x 15.00	180.00
58	15.00 x 12.00	180.00
59	10.00 x 15.00	150.00
60	12.00 x 10.00	120.00
61	8.00 x 12.00	96.00
62	12.00 x 10.00	120.00
63	10.00 x 10.00	100.00
64	15.00 x 10.00	150.00
65	10.00 x 15.00	150.00
66	12.00 x 12.00	144.00
67	15.00 x 15.00	225.00
68	10.00 x 12.00	120.00
69	12.00 x 15.00	180.00
70	15.00 x 12.00	180.00
71	10.00 x 15.00	150.00
72	12.00 x 10.00	120.00
73	8.00 x 12.00	96.00
74	12.00 x 10.00	120.00
75	10.00 x 10.00	100.00
76	15.00 x 10.00	150.00
77	10.00 x 15.00	150.00
78	12.00 x 12.00	144.00
79	15.00 x 15.00	225.00
80	10.00 x 12.00	120.00
81	12.00 x 15.00	180.00
82	15.00 x 12.00	180.00
83	10.00 x 15.00	150.00
84	12.00 x 10.00	120.00
85	8.00 x 12.00	96.00
86	12.00 x 10.00	120.00
87	10.00 x 10.00	100.00
88	15.00 x 10.00	150.00
89	10.00 x 15.00	150.00
90	12.00 x 12.00	144.00
91	15.00 x 15.00	225.00
92	10.00 x 12.00	120.00
93	12.00 x 15.00	180.00
94	15.00 x 12.00	180.00
95	10.00 x 15.00	150.00
96	12.00 x 10.00	120.00
97	8.00 x 12.00	96.00
98	12.00 x 10.00	120.00
99	10.00 x 10.00	100.00
100	15.00 x 10.00	150.00
101	10.00 x 15.00	150.00
102	12.00 x 12.00	144.00
103	15.00 x 15.00	225.00
104	10.00 x 12.00	120.00
105	12.00 x 15.00	180.00
106	15.00 x 12.00	180.00
107	10.00 x 15.00	150.00
108	12.00 x 10.00	120.00
109	8.00 x 12.00	96.00
110	12.00 x 10.00	120.00
111	10.00 x 10.00	100.00
112	15.00 x 10.00	150.00
113	10.00 x 15.00	150.00
114	12.00 x 12.00	144.00
115	15.00 x 15.00	225.00
116	10.00 x 12.00	120.00
117	12.00 x 15.00	180.00
118	15.00 x 12.00	180.00
119	10.00 x 15.00	150.00
120	12.00 x 10.00	120.00

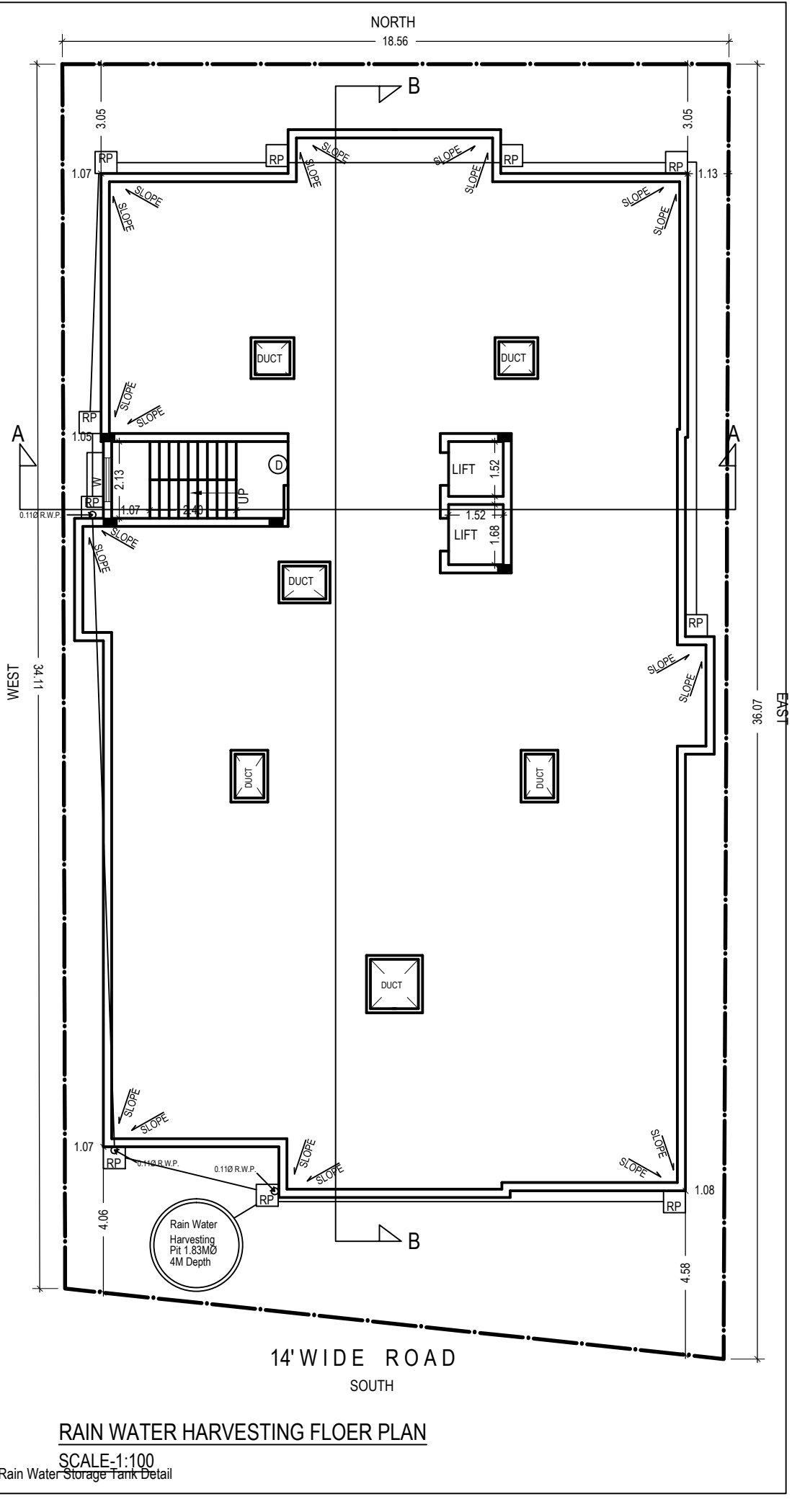
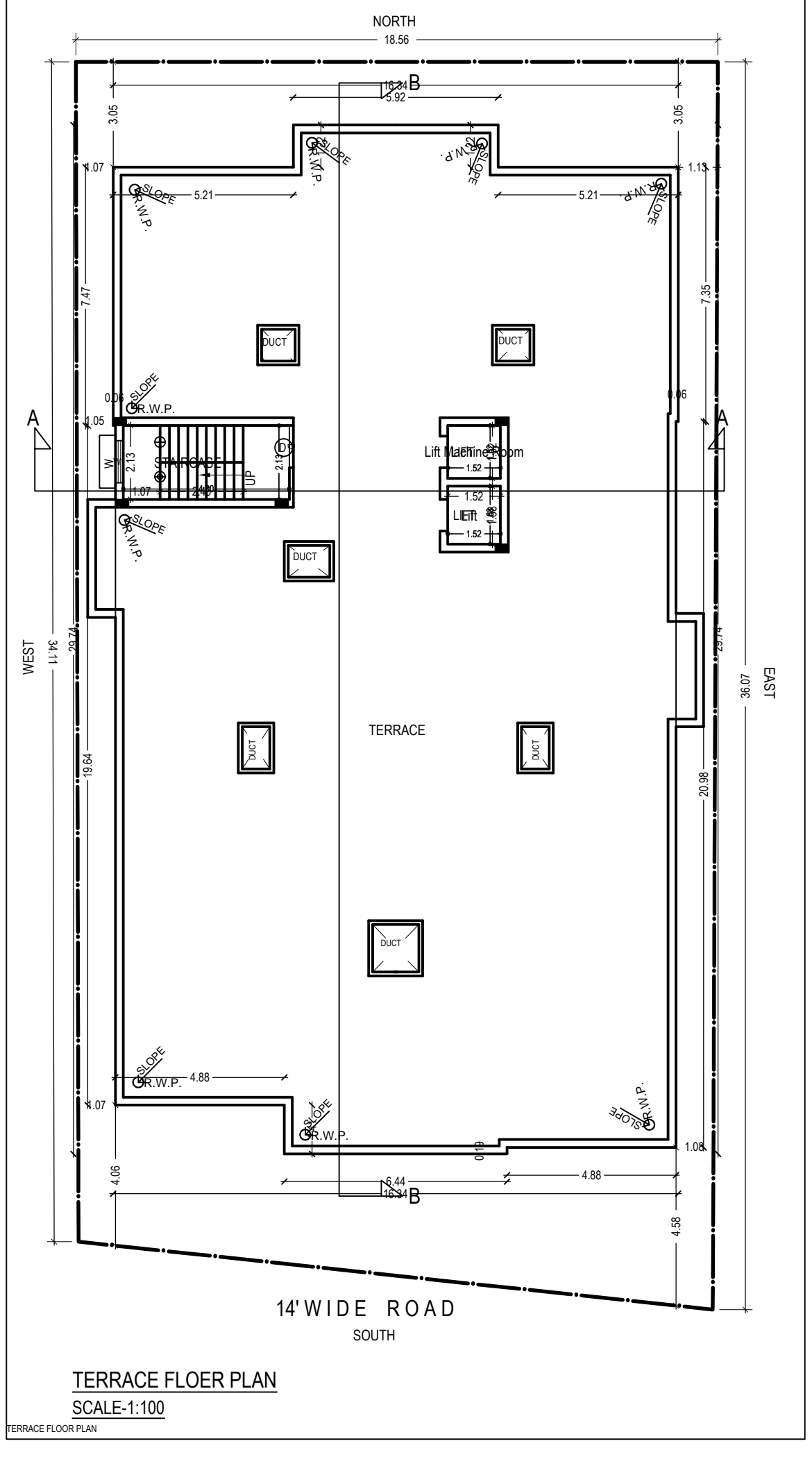
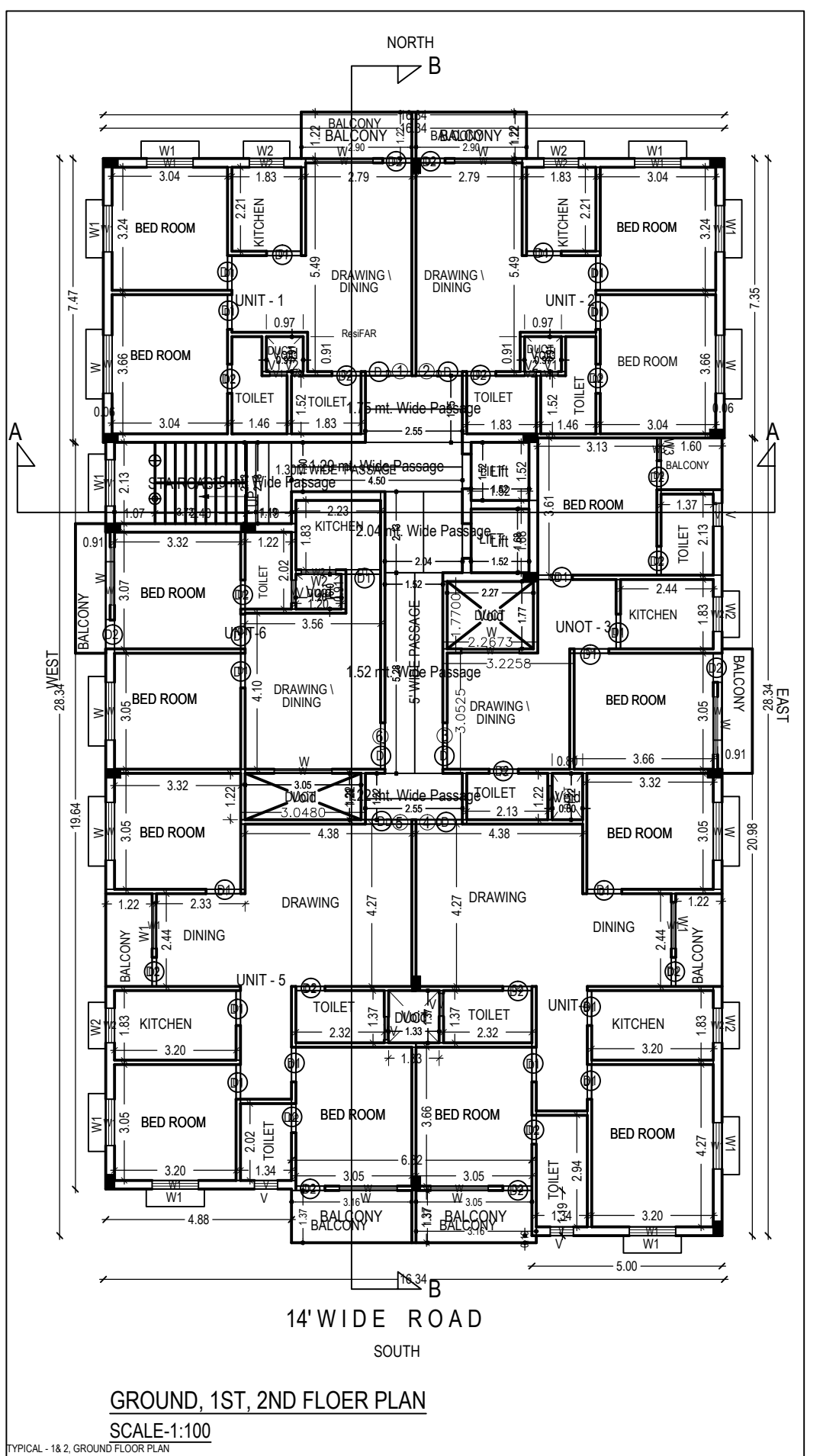
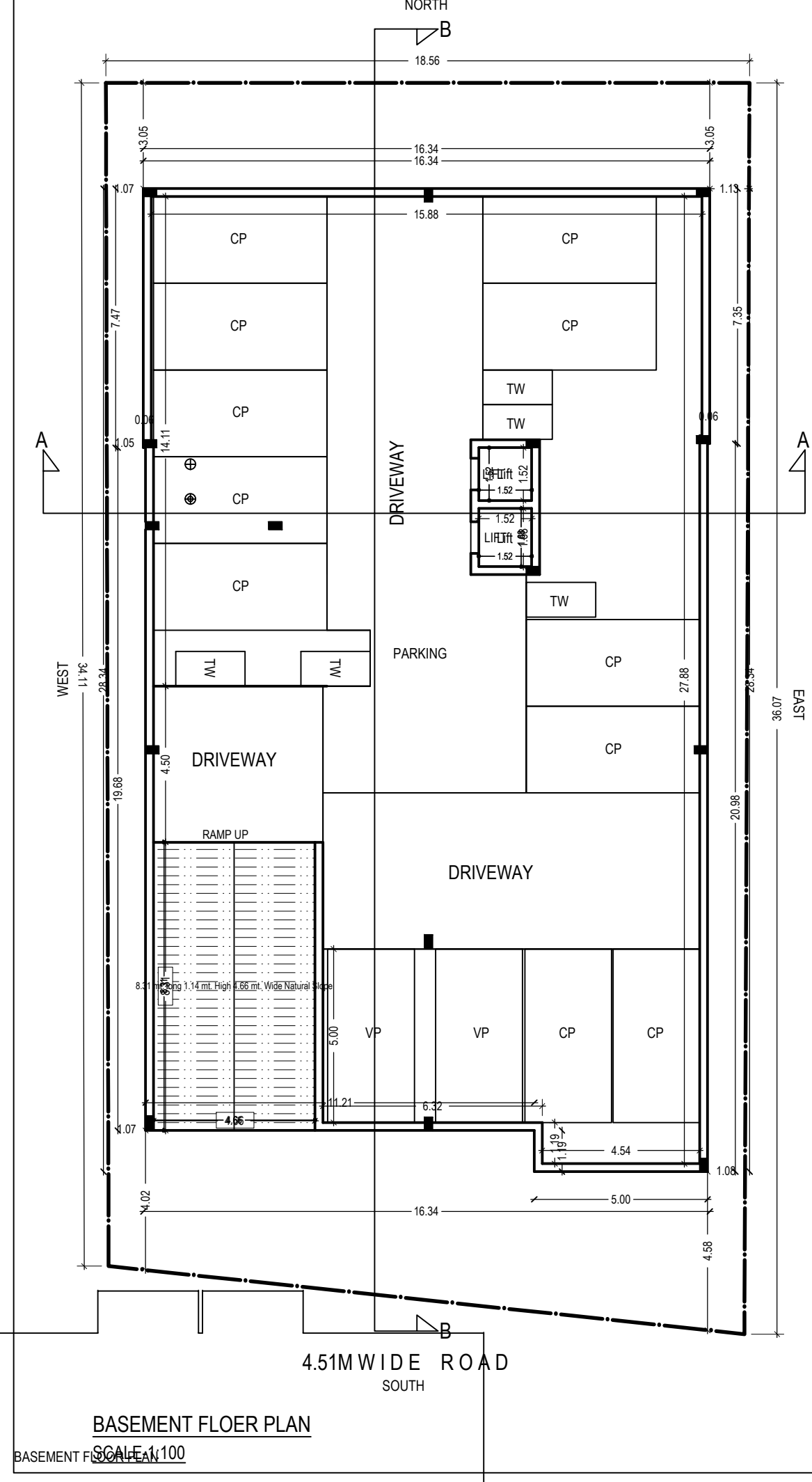
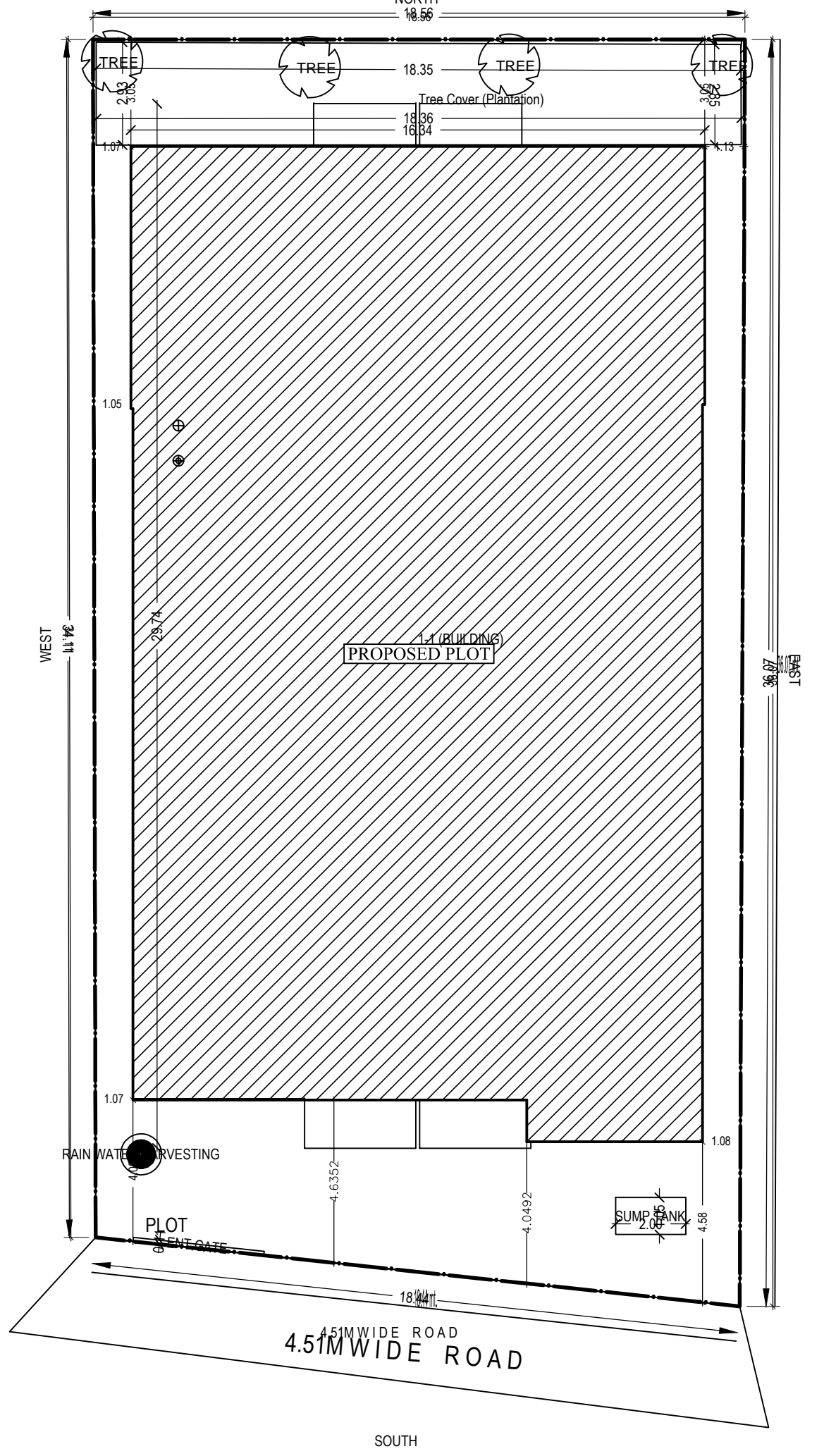
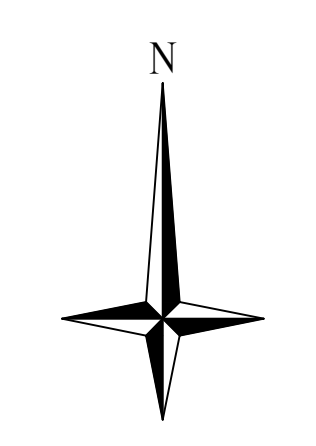
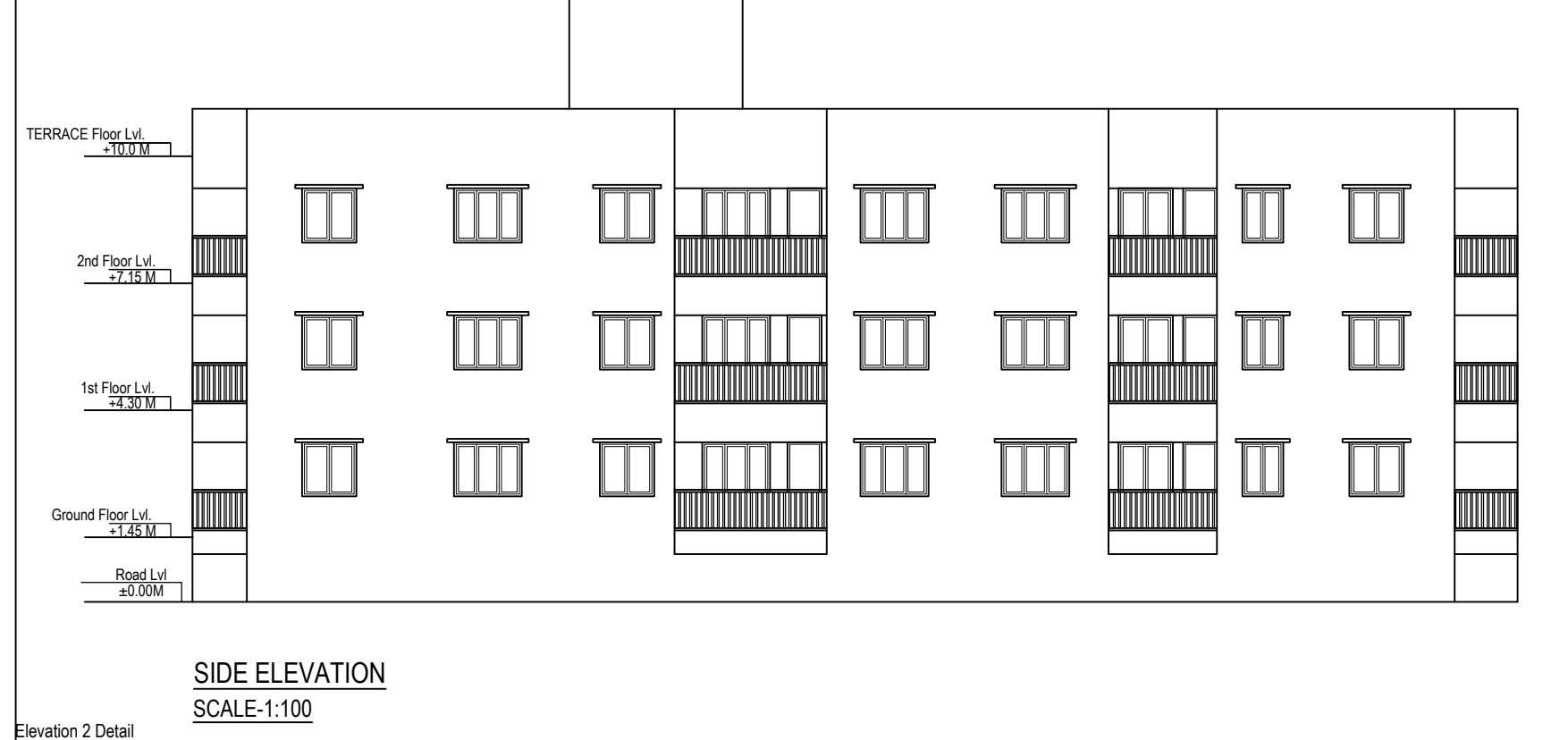
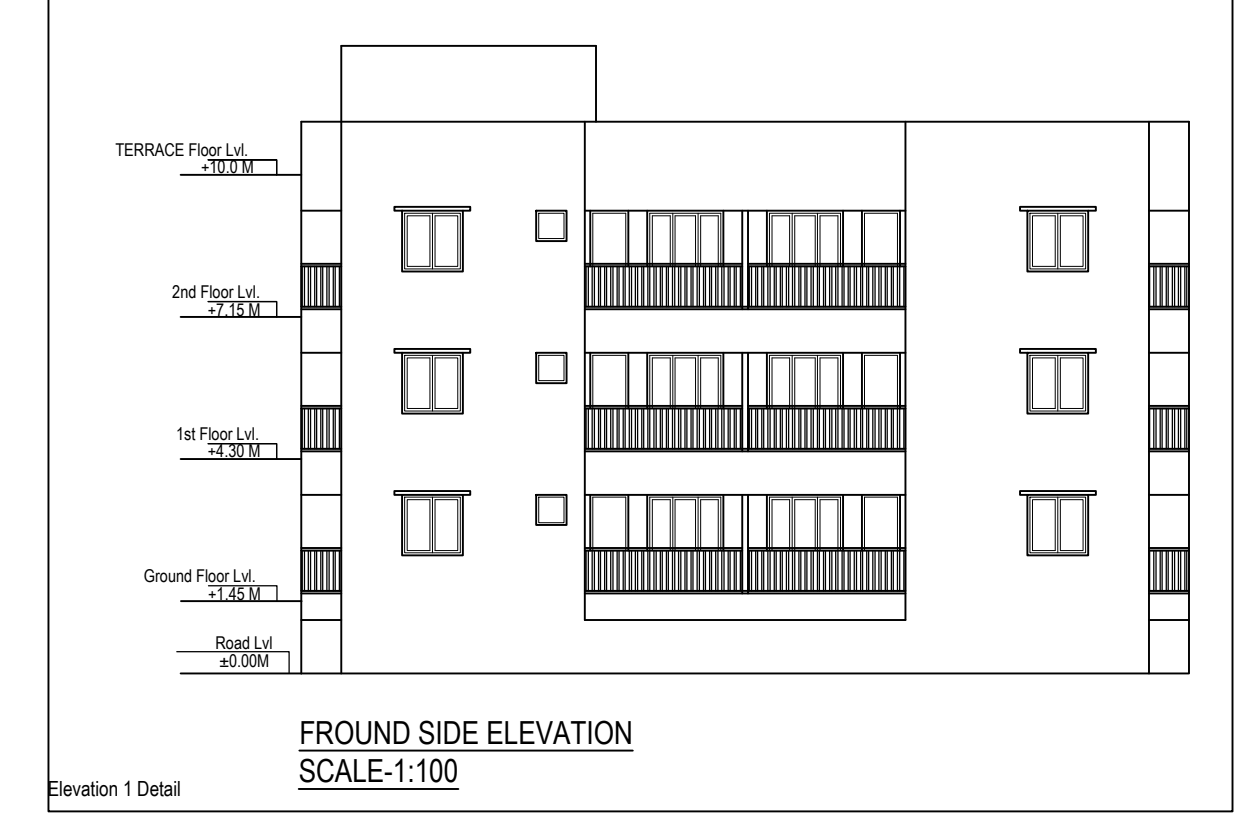
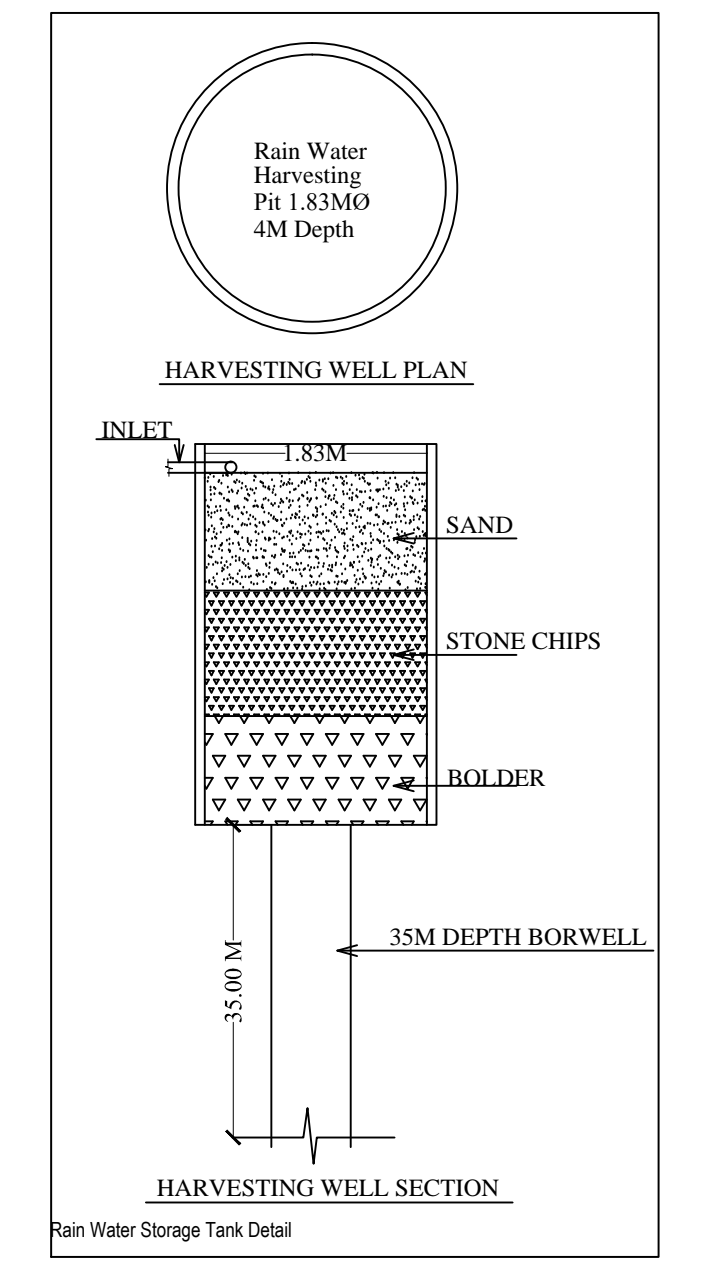
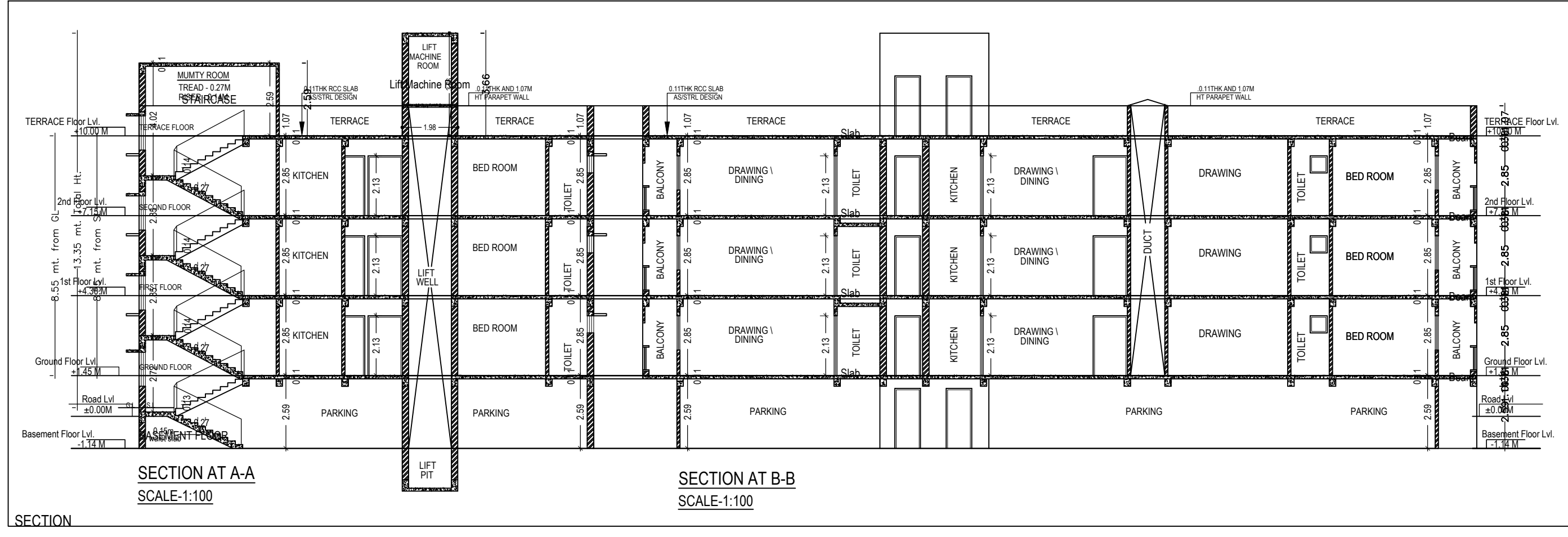
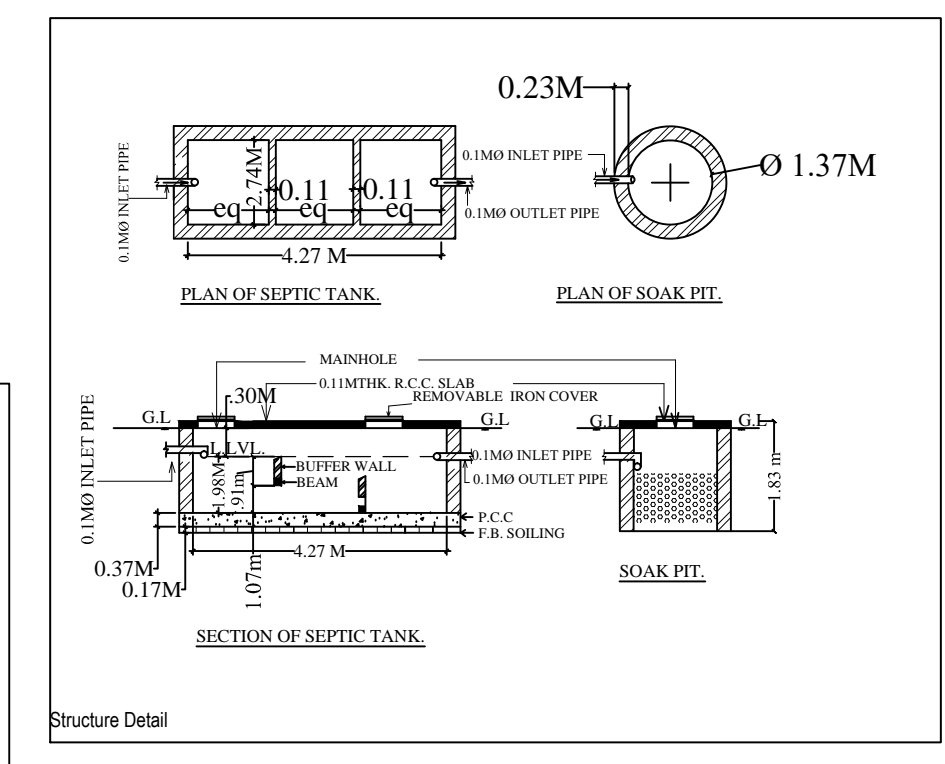
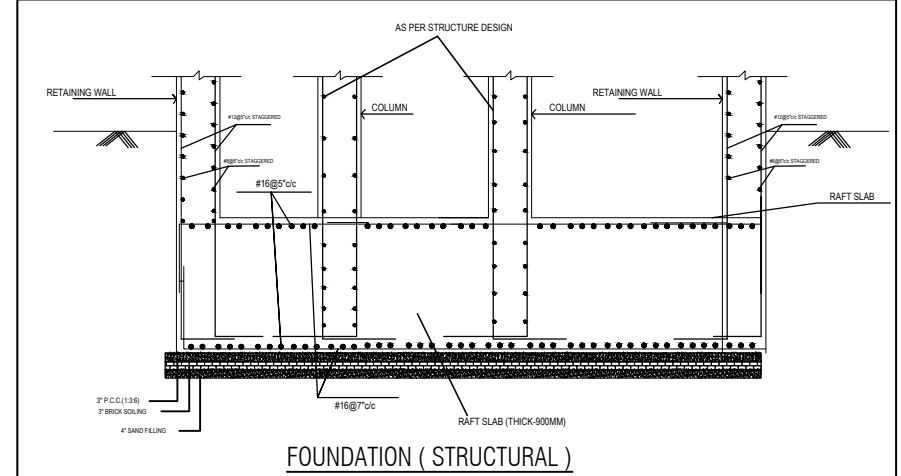
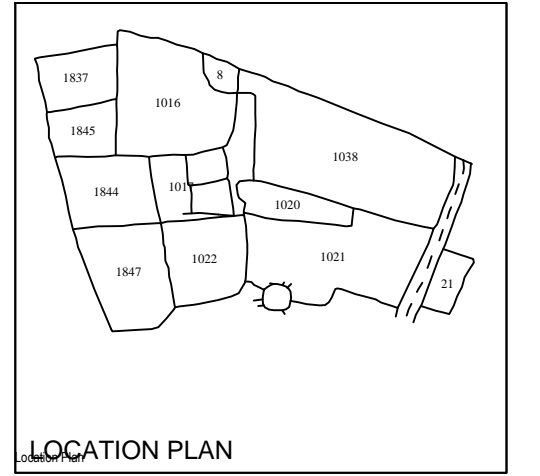

BUILDING 1 (BUILDING)									
Room No.	Room Name	Room Area (Sq. M)	Volume (Cu. M)	Perimeter (M)	Height (M)	Floor Area (Sq. M)	Room Area (Sq. M)	Volume (Cu. M)	Perimeter (M)
1	Living Room	18.00	36.00	36.00	3.00	18.00	18.00	54.00	36.00
2	Kitchen	10.00	20.00	18.00	3.00	10.00	10.00	30.00	18.00
3	Bed Room	12.00	24.00	24.00	3.00	12.00	12.00	36.00	24.00
4	Bed Room	12.00	24.00	24.00	3.00	12.00	12.00	36.00	24.00
5	Bed Room	12.00	24.00	24.00	3.00	12.00	12.00	36.00	24.00
6	Bed Room	12.00	24.00	24.00	3.00	12.00	12.00	36.00	24.00
7	Bed Room	12.00	24.00	24.00	3.00	12.00	12.00	36.00	24.00
8	Bed Room	12.00	24.00	24.00	3.00	12.00	12.00	36.00	24.00
9	Bed Room	12.00	24.00	24.00	3.00	12.00	12.00	36.00	24.00
10	Bed Room	12.00	24.00	24.00	3.00	12.00	12.00	36.00	24.00
11	Bed Room	12.00	24.00	24.00	3.00	12.00	12.00	36.00	24.00
12	Bed Room	12.00	24.00	24.00	3.00	12.00	12.00	36.00	24.00
13	Bed Room	12.00	24.00	24.00	3.00	12.00	12.00	36.00	24.00
14	Bed Room	12.00	24.00	24.00	3.00	12.00	12.00	36.00	24.00
15	Bed Room	12.00	24.00	24.00	3.00	12.00	12.00	36.00	24.00
16	Bed Room	12.00	24.00	24.00	3.00	12.00	12.00	36.00	24.00
17	Bed Room	12.00	24.00	24.00	3.00	12.00	12.00	36.00	24.00
18	Bed Room	12.00	24.00	24.00	3.00	12.00	12.00	36.00	24.00
19	Bed Room	12.00	24.00	24.00	3.00	12.00	12.00	36.00	24.00
20	Bed Room	12.00	24.00	24.00	3.00	12.00	12.00	36.00	24.00