

Project Title : PANKAJ KUMAR AKSHAY

AREA STATEMENT		SECTION NO. 1.18
NO.	DESCRIPTION	AREA (Sq. Mtr)
1	Plot Area	14.40 x 14.40 = 207.36
2	Area of Building	100.00
3	Area of Terrace	10.00
4	Area of Parking	10.00
5	Area of Road	10.00
6	Area of Other	10.00
7	Area of Green Space	10.00
8	Area of Water Body	10.00
9	Area of Other	10.00
10	Area of Other	10.00
11	Area of Other	10.00
12	Area of Other	10.00
13	Area of Other	10.00
14	Area of Other	10.00
15	Area of Other	10.00
16	Area of Other	10.00
17	Area of Other	10.00
18	Area of Other	10.00
19	Area of Other	10.00
20	Area of Other	10.00
21	Area of Other	10.00
22	Area of Other	10.00
23	Area of Other	10.00
24	Area of Other	10.00
25	Area of Other	10.00
26	Area of Other	10.00
27	Area of Other	10.00
28	Area of Other	10.00
29	Area of Other	10.00
30	Area of Other	10.00
31	Area of Other	10.00
32	Area of Other	10.00
33	Area of Other	10.00
34	Area of Other	10.00
35	Area of Other	10.00
36	Area of Other	10.00
37	Area of Other	10.00
38	Area of Other	10.00
39	Area of Other	10.00
40	Area of Other	10.00
41	Area of Other	10.00
42	Area of Other	10.00
43	Area of Other	10.00
44	Area of Other	10.00
45	Area of Other	10.00
46	Area of Other	10.00
47	Area of Other	10.00
48	Area of Other	10.00
49	Area of Other	10.00
50	Area of Other	10.00
51	Area of Other	10.00
52	Area of Other	10.00
53	Area of Other	10.00
54	Area of Other	10.00
55	Area of Other	10.00
56	Area of Other	10.00
57	Area of Other	10.00
58	Area of Other	10.00
59	Area of Other	10.00
60	Area of Other	10.00
61	Area of Other	10.00
62	Area of Other	10.00
63	Area of Other	10.00
64	Area of Other	10.00
65	Area of Other	10.00
66	Area of Other	10.00
67	Area of Other	10.00
68	Area of Other	10.00
69	Area of Other	10.00
70	Area of Other	10.00
71	Area of Other	10.00
72	Area of Other	10.00
73	Area of Other	10.00
74	Area of Other	10.00
75	Area of Other	10.00
76	Area of Other	10.00
77	Area of Other	10.00
78	Area of Other	10.00
79	Area of Other	10.00
80	Area of Other	10.00
81	Area of Other	10.00
82	Area of Other	10.00
83	Area of Other	10.00
84	Area of Other	10.00
85	Area of Other	10.00
86	Area of Other	10.00
87	Area of Other	10.00
88	Area of Other	10.00
89	Area of Other	10.00
90	Area of Other	10.00
91	Area of Other	10.00
92	Area of Other	10.00
93	Area of Other	10.00
94	Area of Other	10.00
95	Area of Other	10.00
96	Area of Other	10.00
97	Area of Other	10.00
98	Area of Other	10.00
99	Area of Other	10.00
100	Area of Other	10.00
101	Area of Other	10.00
102	Area of Other	10.00
103	Area of Other	10.00
104	Area of Other	10.00
105	Area of Other	10.00
106	Area of Other	10.00
107	Area of Other	10.00
108	Area of Other	10.00
109	Area of Other	10.00
110	Area of Other	10.00
111	Area of Other	10.00
112	Area of Other	10.00
113	Area of Other	10.00
114	Area of Other	10.00
115	Area of Other	10.00
116	Area of Other	10.00
117	Area of Other	10.00
118	Area of Other	10.00
119	Area of Other	10.00
120	Area of Other	10.00
121	Area of Other	10.00
122	Area of Other	10.00
123	Area of Other	10.00
124	Area of Other	10.00
125	Area of Other	10.00
126	Area of Other	10.00
127	Area of Other	10.00
128	Area of Other	10.00
129	Area of Other	10.00
130	Area of Other	10.00
131	Area of Other	10.00
132	Area of Other	10.00
133	Area of Other	10.00
134	Area of Other	10.00
135	Area of Other	10.00
136	Area of Other	10.00
137	Area of Other	10.00
138	Area of Other	10.00
139	Area of Other	10.00
140	Area of Other	10.00
141	Area of Other	10.00
142	Area of Other	10.00
143	Area of Other	10.00
144	Area of Other	10.00
145	Area of Other	10.00
146	Area of Other	10.00
147	Area of Other	10.00
148	Area of Other	10.00
149	Area of Other	10.00
150	Area of Other	10.00

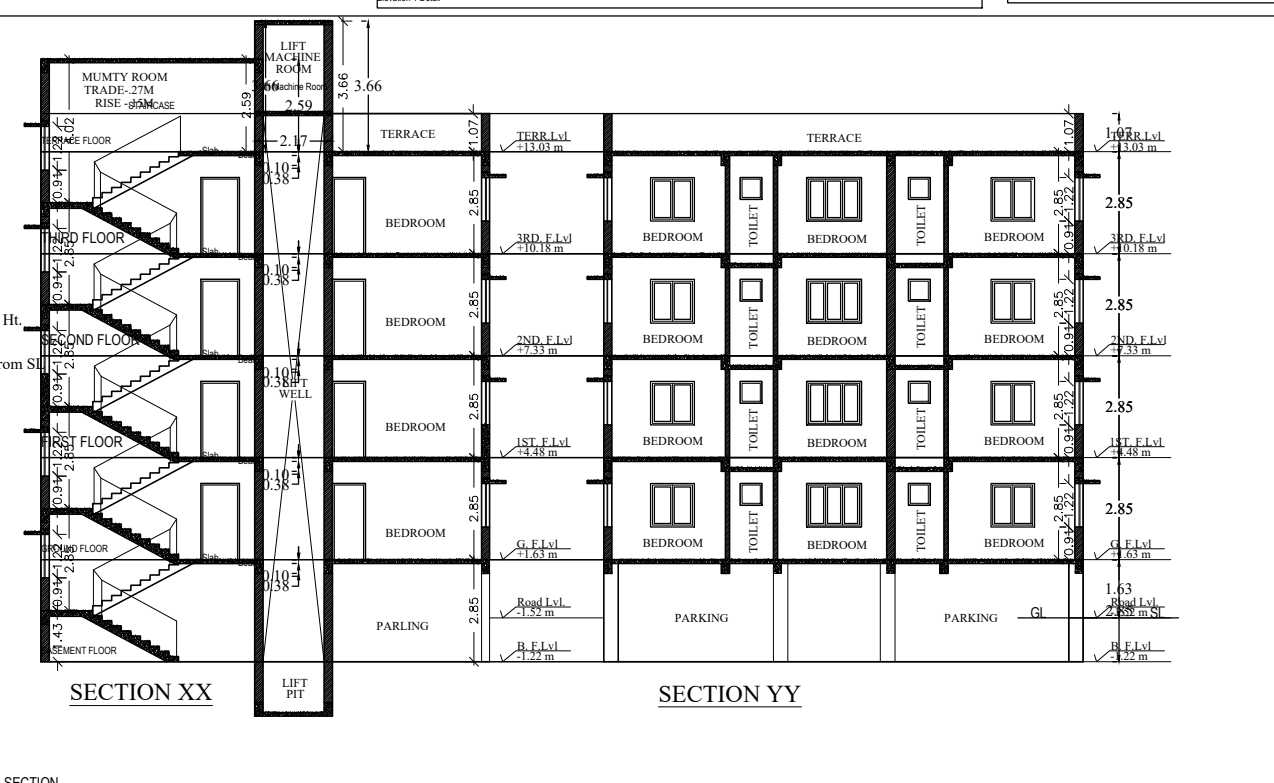
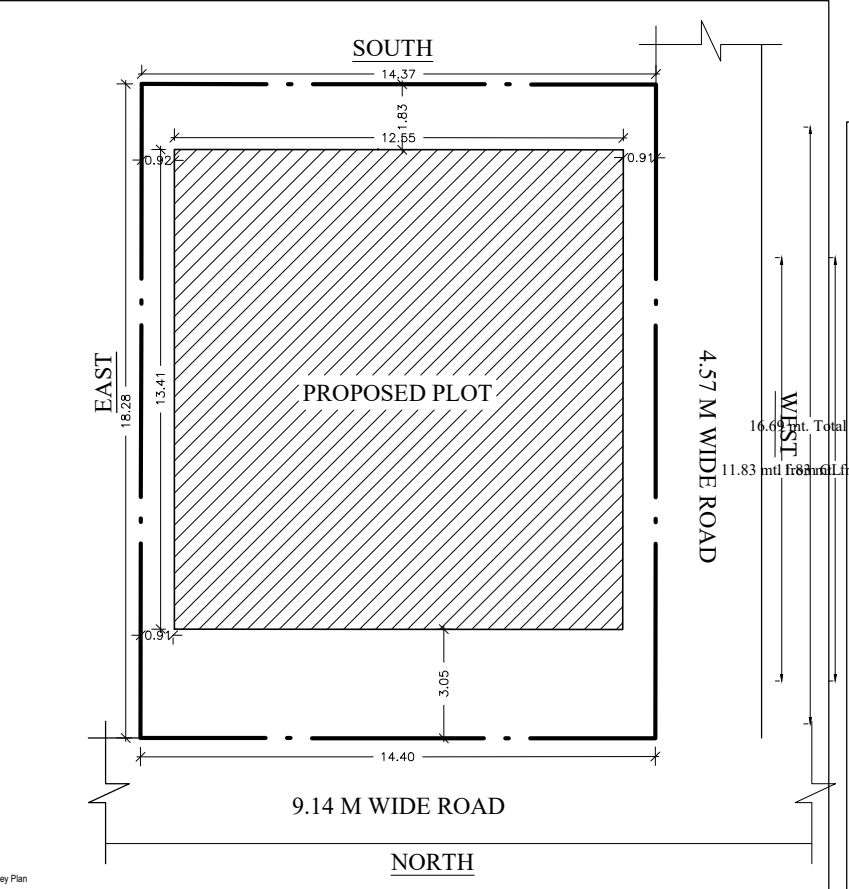
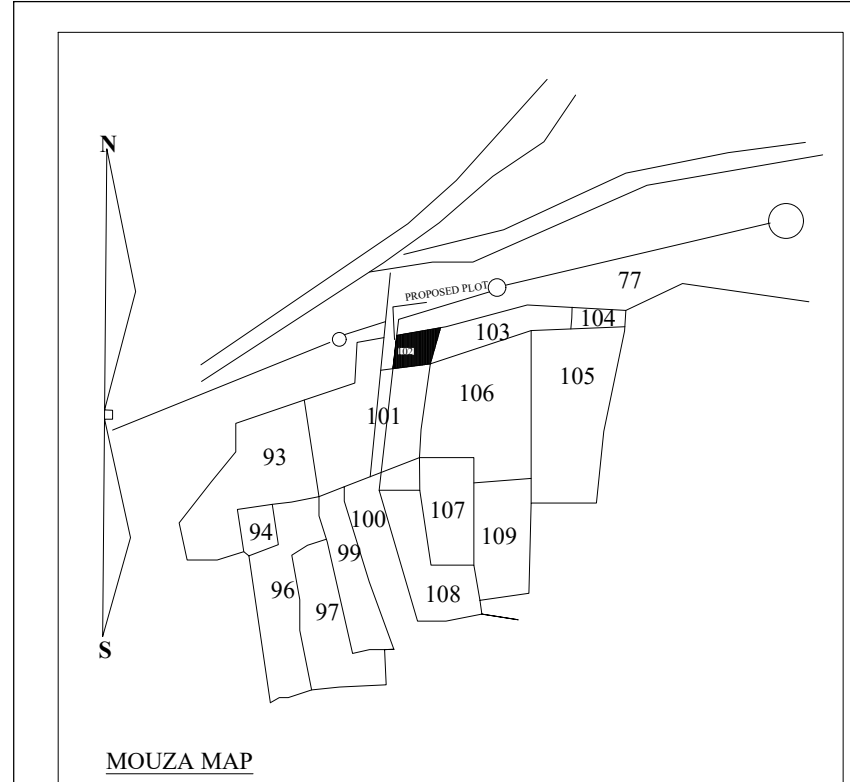
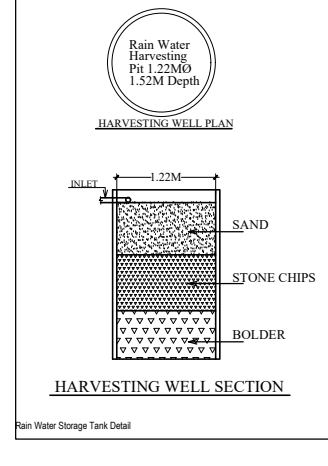
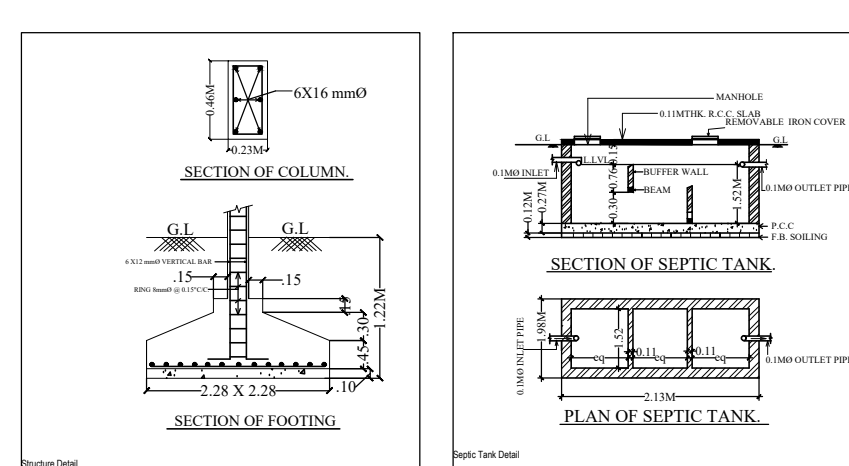

LEGEND

SL. NO.	SYMBOL	DESCRIPTION
1	■	PERCOLATION CHAMBER WITH 1500 MPT
2	○	PERCOLATION PIT
3	■	WASTE WATER CHAMBER
4	○	1000 R.P.P FROM BUILDING TERRACE

GENERAL SPECIFICATION

CONCRETE: M20 (MINIMUM) AS PER DESIGN.

STEEL: FE 415 (MINIMUM) AS PER DESIGN.

ROOFING: BITUMEN FELT ON RCC ROOF.

WALLS: 230 MM THICK BRICK WALL WITH 10% PORTLAND CEMENT MORTAR.

FLOORING: POLISHED TERRAZZO OR POLISHED MARBLE.

PAINTS: EMULSION PAINT.

GLAZING: GLASS WITH ALUMINIUM FRAME.

DOORS: 1000 X 2100 MM WITH 10% PORTLAND CEMENT MORTAR.

WINDOWS: 1000 X 1200 MM WITH 10% PORTLAND CEMENT MORTAR.

ROOFING: BITUMEN FELT ON RCC ROOF.

WALLS: 230 MM THICK BRICK WALL WITH 10% PORTLAND CEMENT MORTAR.

FLOORING: POLISHED TERRAZZO OR POLISHED MARBLE.

PAINTS: EMULSION PAINT.

GLAZING: GLASS WITH ALUMINIUM FRAME.

DOORS: 1000 X 2100 MM WITH 10% PORTLAND CEMENT MORTAR.

WINDOWS: 1000 X 1200 MM WITH 10% PORTLAND CEMENT MORTAR.

SCHEDULE OF DOORS & WINDOWS

SL. NO.	SYMBOL	SIZE	DESCRIPTION
1	D	1000 X 2100	Painted single door
2	W	1000 X 1200	Painted single window
3	W	1000 X 1200	Painted double window
4	W	1000 X 1200	Glazed steel framed window 1. shut.
5	W	1000 X 1200	Glazed steel framed window 2. shut.
6	V	1000 X 1200	Top hung steel ventilator

APPROVED FOR THE ARCHITECT BY:

MR. PANKAJ KUMAR AKSHAY

SO MR. BINOD LAL KARAN

PLOT NO. 100/101

KHATA NO. 53

THANA NO. 43

THANA: GAMBHARIA

WARD NO. -3(0,2IN)

MOUZA -JALPUR

DISTRICT -SARKELA KHARSAWA

SCALE: 1:100 NORTH SHEET NO. 1

DATE: -

SIGNATURE OF ARCHITECT

SIGNATURE ATTORNEY HOLDER/OWNER

APPROVED

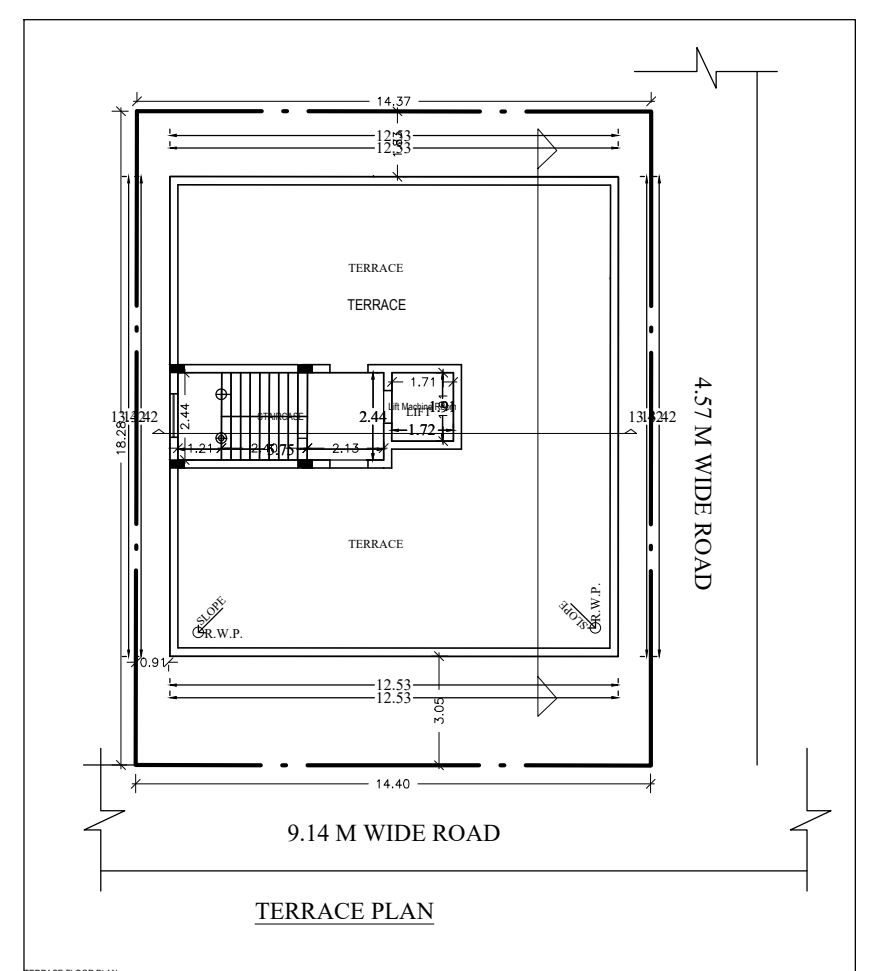
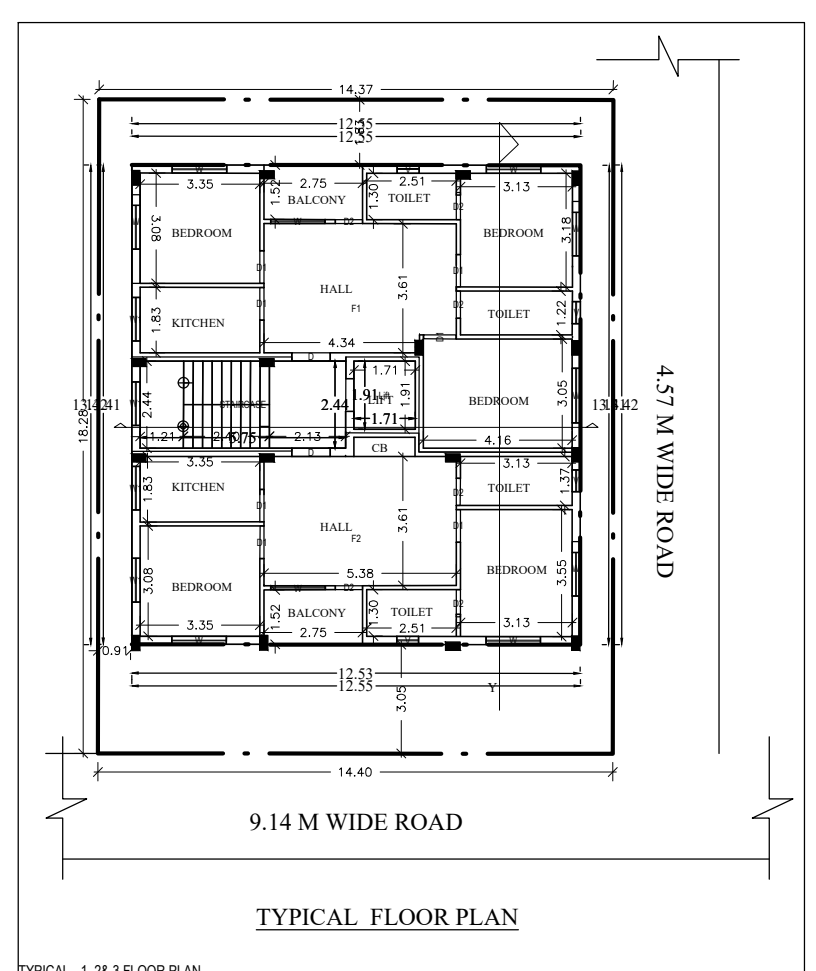
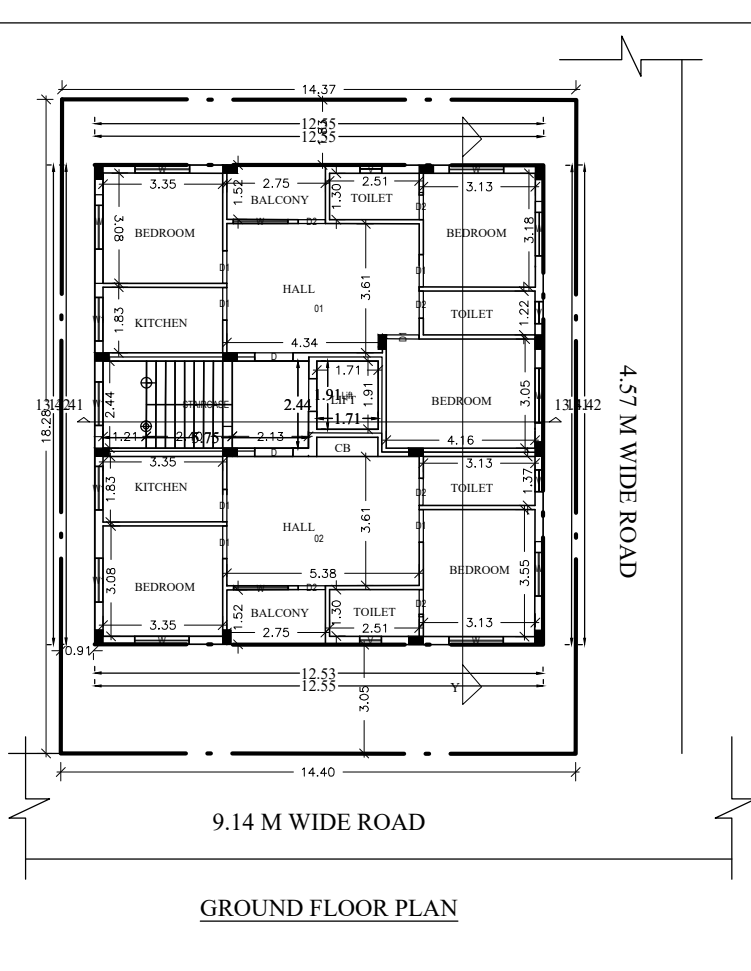
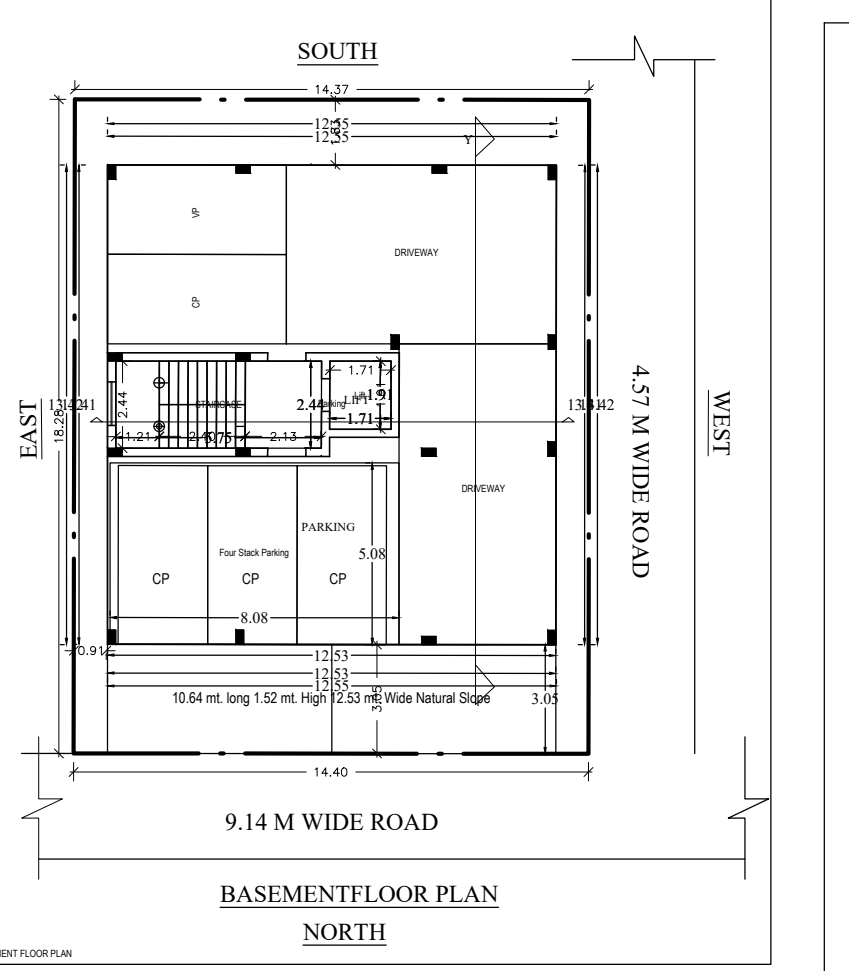
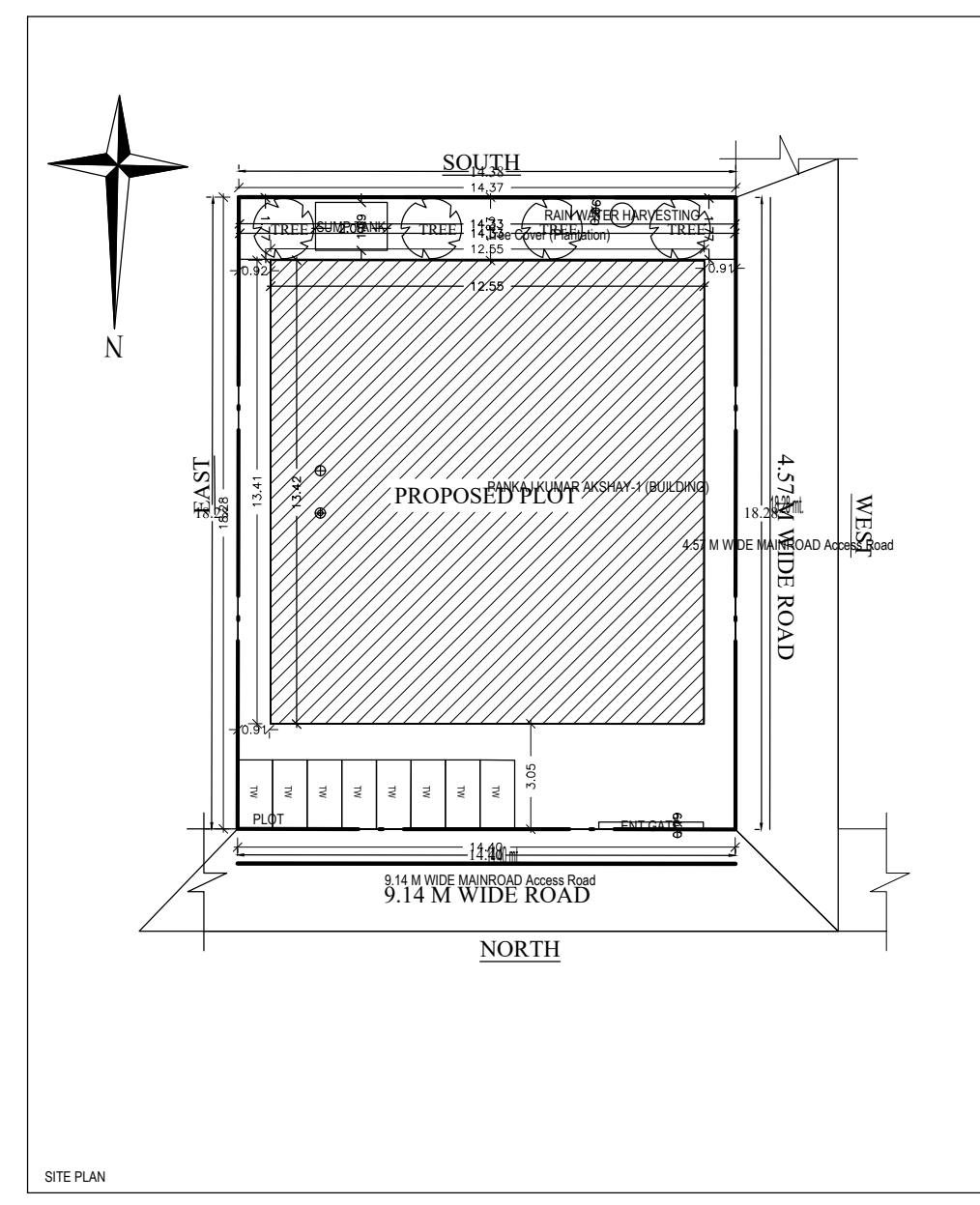

Building PANKAJ KUMAR AKSHAY (BUILDING)

Room Name	Area (Sq. Mtr)	Volume (Cu. Mtr)	Perimeter (Mtr)	Area (Sq. Mtr)	Volume (Cu. Mtr)	Perimeter (Mtr)
Basement	100.00	0.00	14.40	100.00	0.00	14.40
Ground Floor	100.00	0.00	14.40	100.00	0.00	14.40
Typical Floor	100.00	0.00	14.40	100.00	0.00	14.40
Terrace	10.00	0.00	14.40	10.00	0.00	14.40
Total	310.00	0.00	57.60	310.00	0.00	57.60

SCHEDULE OF JOINERY

Room Name	Material	Length (Mtr)	Height (Mtr)	MSQ
Basement	CP	0.76	2.13	34
Ground Floor	CP	0.91	2.13	38
Typical Floor	CP	1.07	2.13	45
Terrace	-	-	-	00

SCHEDULE OF JOINERY

Room Name	Material	Length (Mtr)	Height (Mtr)	MSQ
Basement	V	0.91	1.08	16
Ground Floor	W	1.22	2.46	16
Typical Floor	W	1.52	2.46	40
Terrace	-	-	-	00

Area Table for Building PANKAJ KUMAR AKSHAY (BUILDING)

FLOOR	Name	Area (Sq. Mtr)	Volume (Cu. Mtr)	Perimeter (Mtr)	No. of Rooms
Basement	Basement	100.00	0.00	14.40	2
Ground Floor	Ground Floor	100.00	0.00	14.40	2
Typical Floor	Typical Floor	100.00	0.00	14.40	2
Terrace	Terrace	10.00	0.00	14.40	2
Total	Total	310.00	0.00	57.60	8