

Proposal Basic Information

Proposal File No.	AMC/BP/0103/W22/2022
Owner Name	TECHNOCULTURE BUILDING CENTRE PRIVATE LIMITED
Khata No	234,113
Plot No	453,2492
Village Name	ASANGI
Use	Residential
SubUse	Bungalow/ Dwelling / Non Apartment

AREA STATEMENT

ADITYAPUR MUNICIPAL CORPORATION	VERSION NO. : 1.0.64
PROJECT DETAIL:	VERSION DATE: 16/10/2020
Region: JHARKHAND URBAN LOCAL BODIES	Plot Use: Residential
District: EAST SINGHBHUM	Plot SubUse: Bungalow/ Dwelling / Non Apartment
Authority: ADITYAPUR MUNICIPAL CORPORATION	Plot/Nearby/Religious/Structure: NA
Inward No: AMC/BP/0103/W22/2022	Plot/SubPlot No: 453,2492
Application Type: General Proposal	North: -
Project Type: Building Permission	South: -
Nature of Development: New	East: -
Location of Development Area: Old Area	West: -

AREA DETAILS:

AREA OF PLOT (Minimum)	(A)	SQ.MT.	150.36
NET AREA OF PLOT (Gross Plot Area - Deduction from Gross Plot area)	(A-Deductions)	150.36	150.36
Deduction for Balance Plot Area (from Gross Plot Area)			
Common Plot		8.21	8.21
BALANCE AREA OF PLOT (Net Plot Area - Recreational/Amenity space)			
(A-Deductions)		142.14	142.14
PLOT AREA FOR COVERAGE (Net Plot Area)			
(A-Deductions)		150.36	150.36
Plot Area for FAR (Net Plot Area + Road Widening Area)			
(A-Deductions)		150.36	150.36
COVERAGE CHECK			
Permissible Coverage area (70.00 %)		105.25	105.25
Proposed Coverage Area (54.22 %)		81.52	81.52
Total Prop. Coverage Area (54.22 %)		81.52	81.52
Balance coverage area (15.78 %)		23.73	23.73
FAR CHECK			
Perm. FAR Area (2.500)		375.90	375.90
Total Perm. FAR area		375.90	375.90
Residential FAR		184.72	184.72
Proposed FAR Area		184.72	184.72
Total Proposed FAR Area		184.72	184.72
Consumed FAR (Factor)		1.23	1.23
Balance FAR Area		191.18	191.18
BUILT UP AREA CHECK			
Total Proposed BuiltUp Area		184.71	184.71
ARCHITECT (Regd)		MOHAMMAD BELAL NASIR	
ENGINEER (Regd)			
SUPERVISOR (Regd)			
OWNER (Regd)		TECHNOCULTURE BUILDING CENTRE PRIVATE LIMITED	
DEVELOPMENT AUTHORITY		LOCAL BODY	

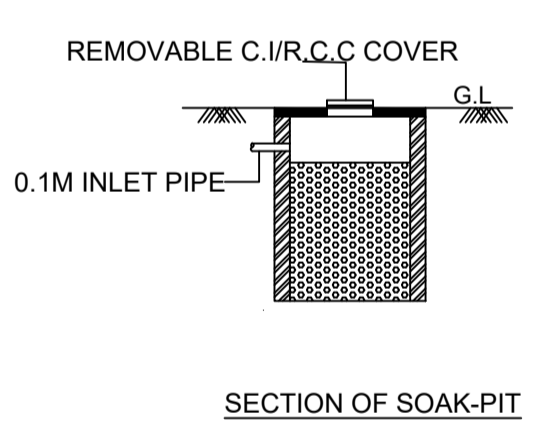
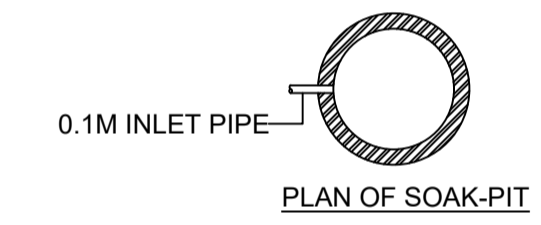
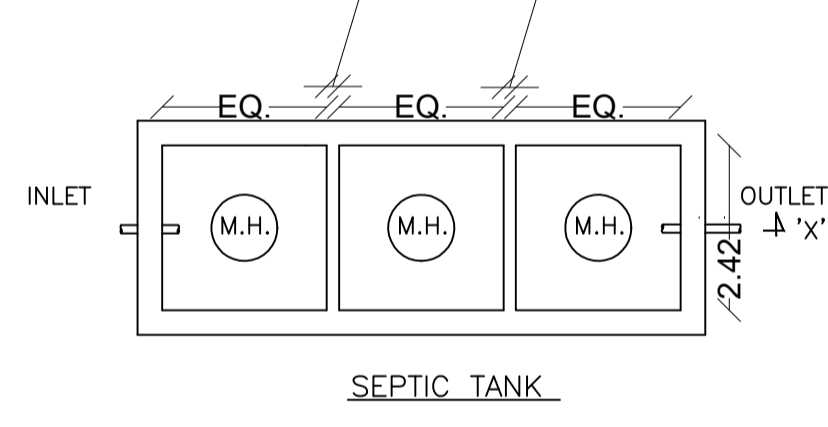
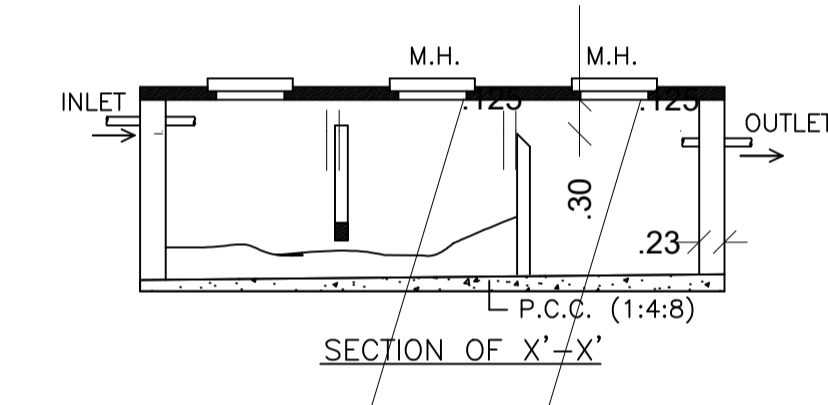
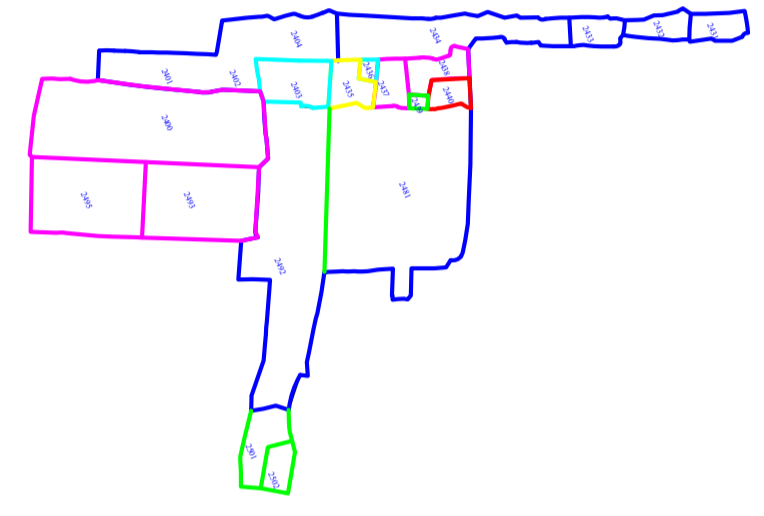
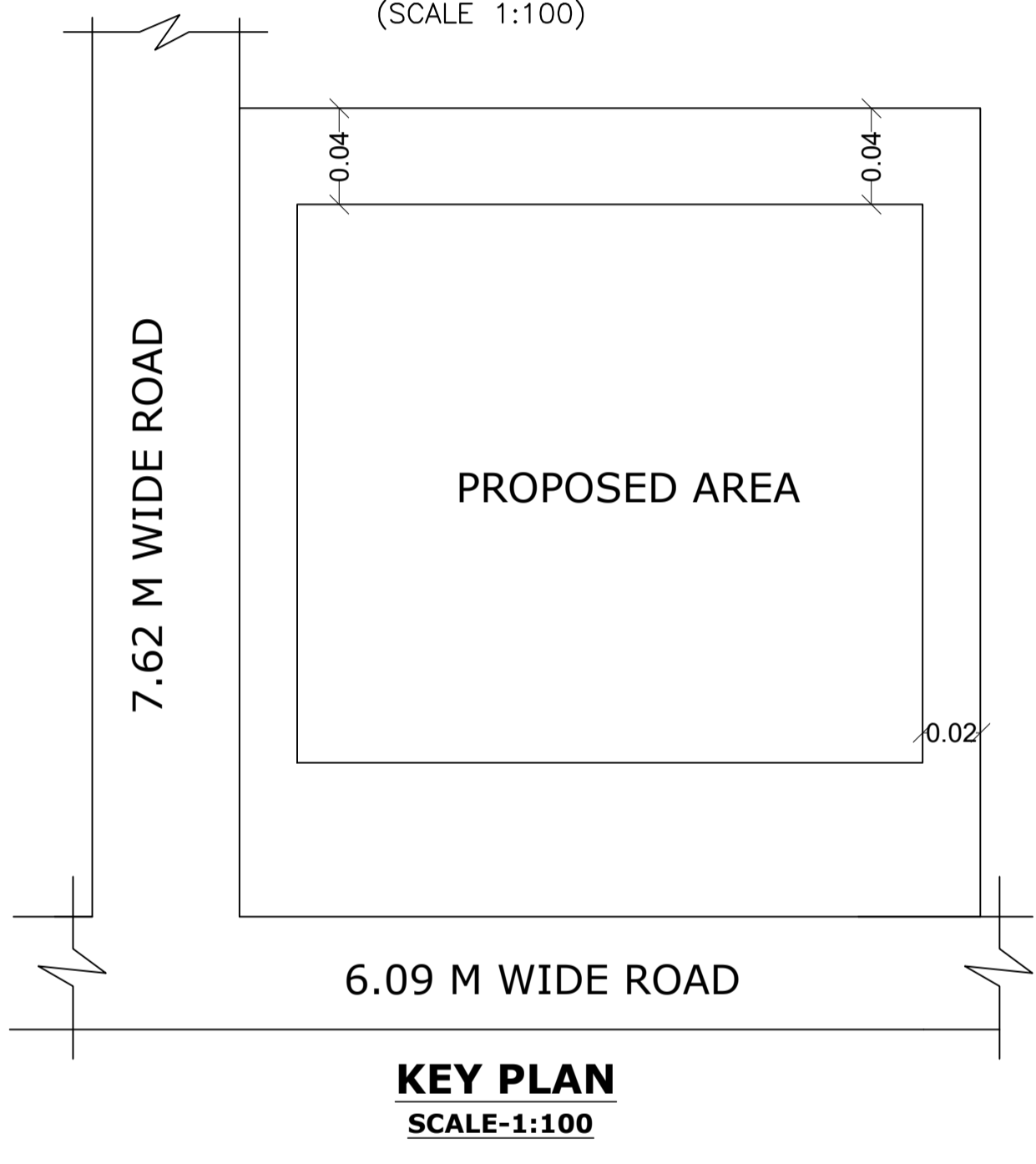
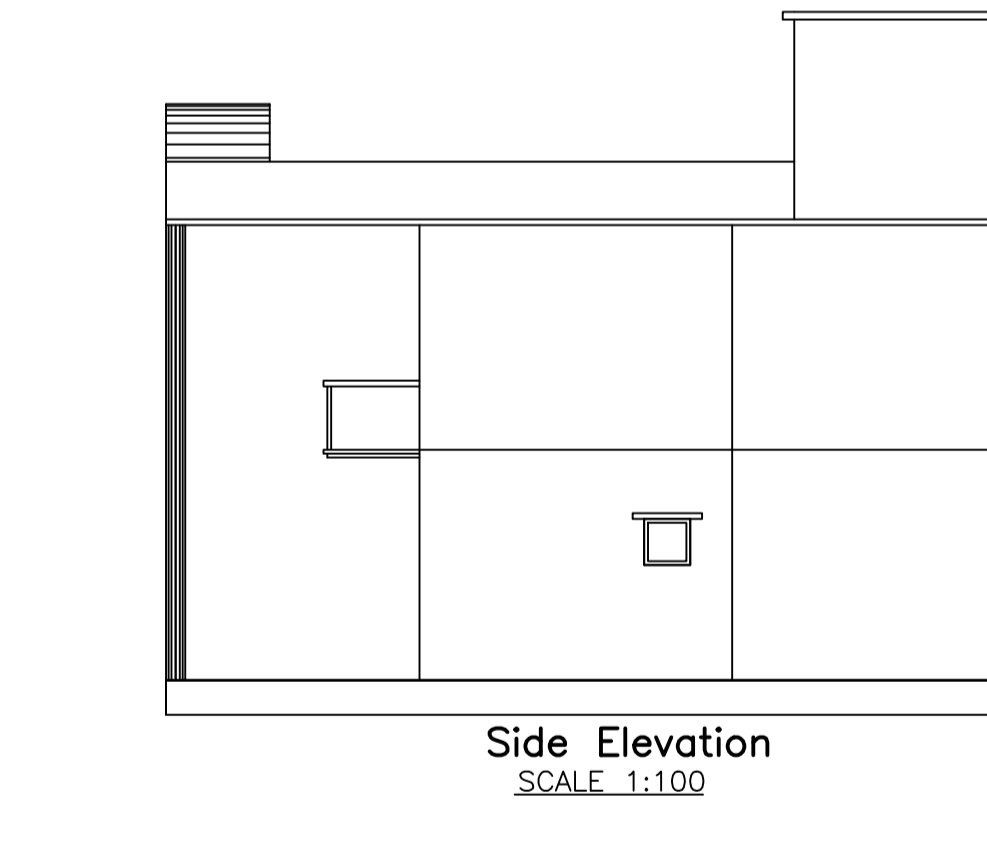
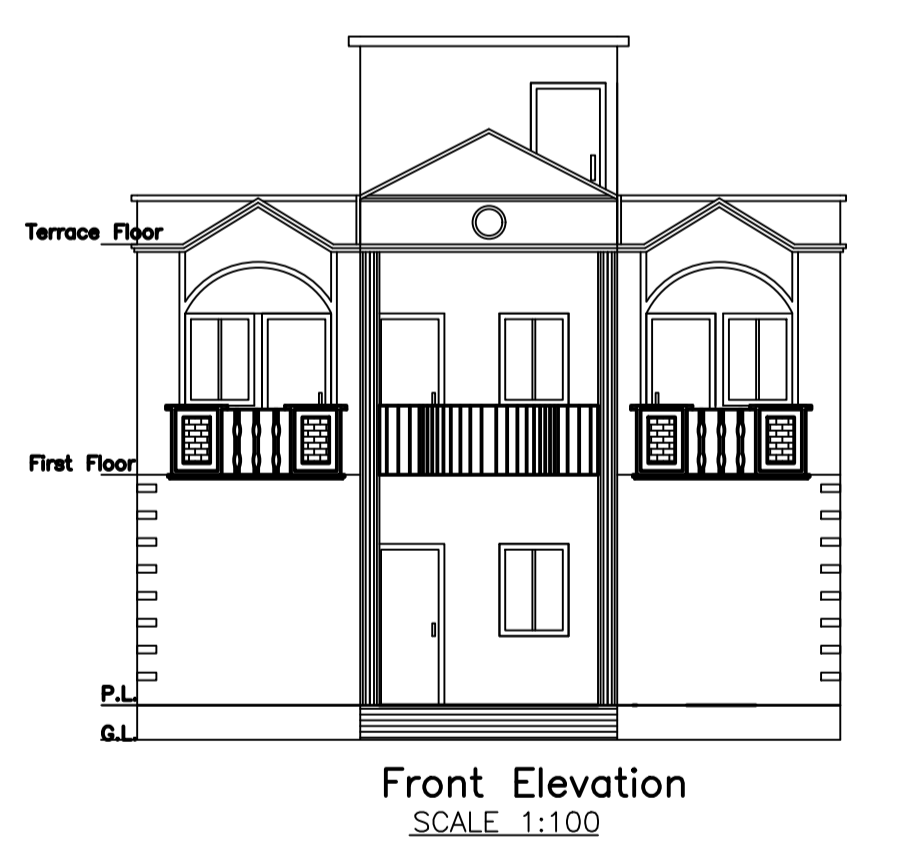
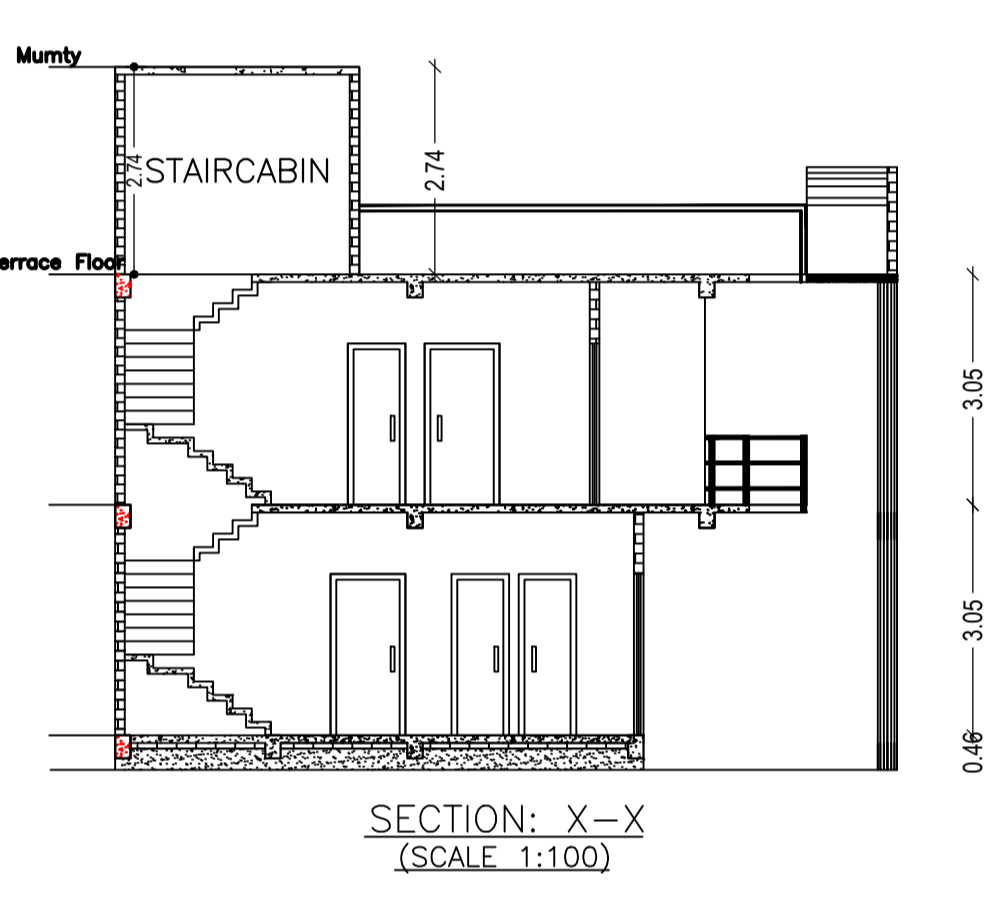
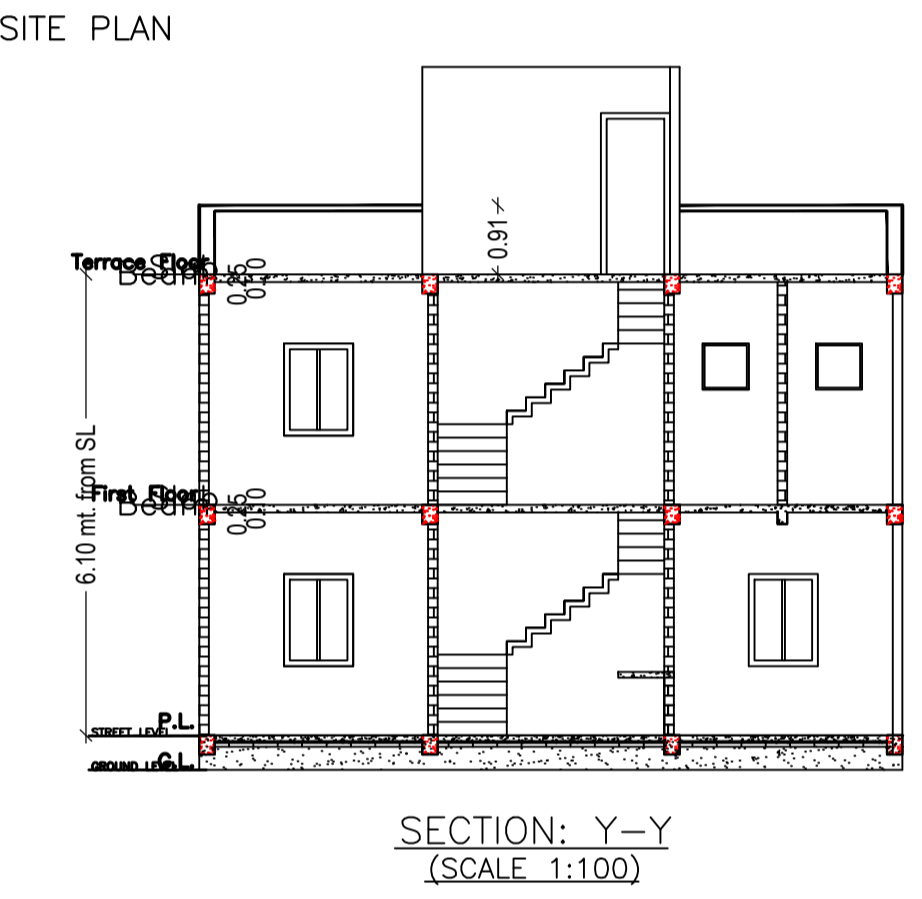

COLOR INDEX

PLOT BOUNDARY	Black
ABUTTING ROAD	Red
PROPOSED CONSTRUCTION	Green
COMMON PLOT	Yellow
ROAD WIDENING AREA	Blue
EXISTING (To be retained)	Light Blue
EXISTING (To be demolished)	Light Yellow

SCHEDULE OF DOOR:

BUILDING NAME	NAME	LENGTH	HEIGHT	NOS
A (TECHNO CULTURE BUILDING PVT LTD)	D2	0.76	2.10	06
A (TECHNO CULTURE BUILDING PVT LTD)	D2	0.86	2.10	01
A (TECHNO CULTURE BUILDING PVT LTD)	D1	0.99	2.10	08
A (TECHNO CULTURE BUILDING PVT LTD)	D1	1.07	2.10	01

SCHEDULE OF WINDOW/VENTILATION:

BUILDING NAME	NAME	LENGTH	HEIGHT	NOS
A (TECHNO CULTURE BUILDING PVT LTD)	V	0.51	1.20	02
A (TECHNO CULTURE BUILDING PVT LTD)	V	0.71	1.20	01
A (TECHNO CULTURE BUILDING PVT LTD)	W2	0.97	1.20	03
A (TECHNO CULTURE BUILDING PVT LTD)	W1	1.17	1.20	07
A (TECHNO CULTURE BUILDING PVT LTD)	W	1.73	1.20	02

UnitBUA Table for Building :A (TECHNO CULTURE BUILDING PVT LTD)

FLOOR	Name	UnitBUA Type	UnitBUA Area (Sq.mt.)	Carpet Area (Sq.mt.)	No. of Rooms	No. of Tenement
GROUND FLOOR PLAN	SPLIT A	FLAT	184.72	168.13	6	1
FIRST FLOOR PLAN	SPLIT A	FLAT	0.00	0.00	10	0
Total:	-	-	184.72	168.13	16	1

Building :A (TECHNO CULTURE BUILDING PVT LTD)

Floor Name	Total Built Up Area (Sq.mt.)	Proposed FAR Area (Sq.mt.) Res.	Total FAR Area (Sq.mt.)	Total Consumed Additional FAR Area (Sq.mt.)	Tnmt (No.)
Ground Floor	81.52	81.52	81.52	81.52	01
First Floor	103.19	103.19	103.19	103.19	00
Terrace Floor	0.00	0.00	0.00	0.00	00
Total:	184.71	184.71	184.71	184.71	01
Total Number of Same Buildings :	1				
Total :	184.71	184.71	184.71	184.71	01

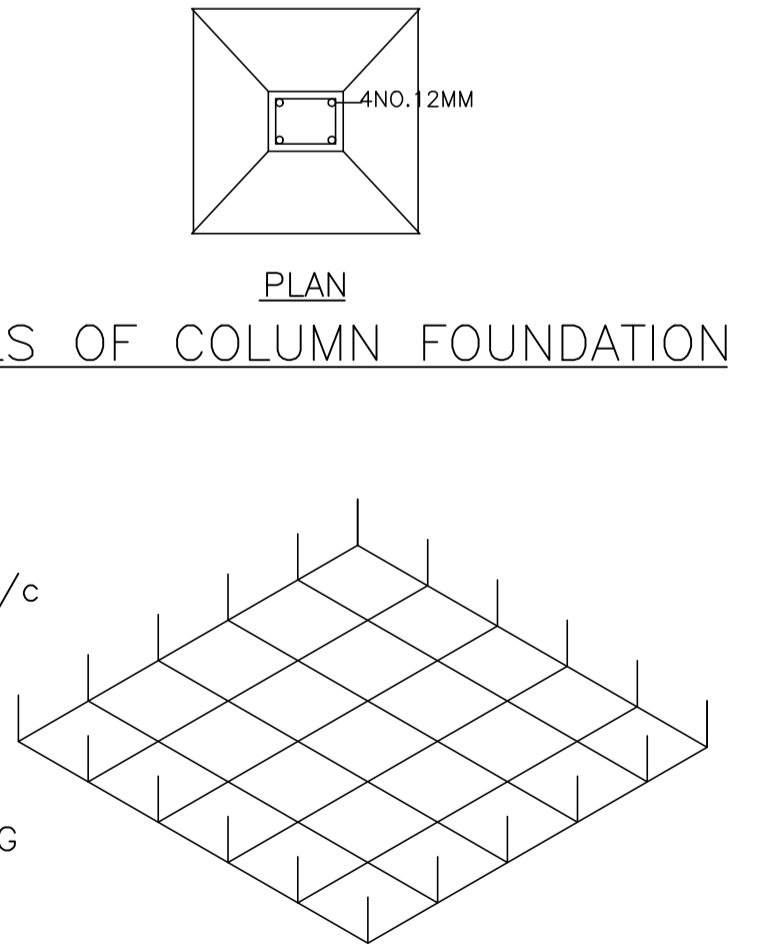
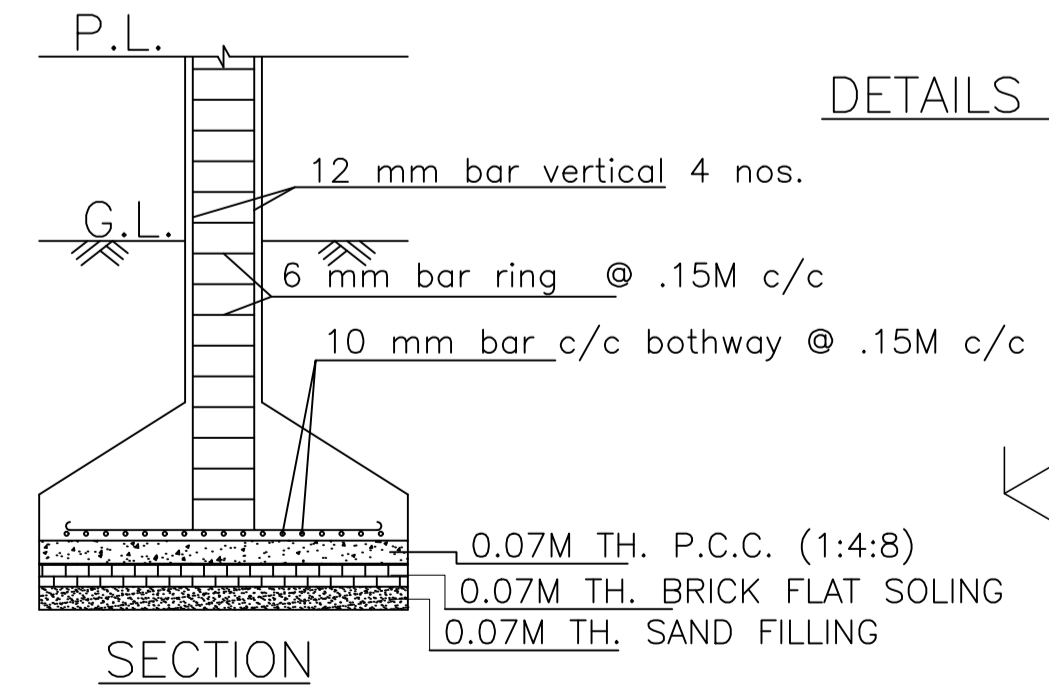

Building USE/SUBUSE Details

Building Name	Building Use	Building SubUse	Building Structure
A (TECHNO CULTURE BUILDING PVT LTD)	Residential	Bungalow/ Dwelling / Non Apartment	Non-Highrise

FAR & Tenement Details (Table 4c-1)

Building	No. of Same Bldg	Total Built Up Area (Sq.mt.)	Proposed FAR Area (Sq.mt.) Res.	Total FAR Area (Sq.mt.)	Total Consumed Additional FAR Area (Sq.mt.)	Tnmt (No.)
A (TECHNO CULTURE BUILDING PVT LTD)	1	184.71	184.71	184.71	184.71	01
Grand Total :	1	184.71	184.71	184.71	184.71	01

LTP NAME AND SIGNATURE: MOHAMMAD BELAL NASIR, AMC/ENG/0015/2017