

GROUND FLOOR PLAN (Proposed) (SCALE 1:100)

FIRST FLOOR PLAN (Proposed) (SCALE 1:100)

SECOND FLOOR PLAN (Proposed) (SCALE 1:100)

TERRACE FLOOR PLAN (SCALE 1:100)

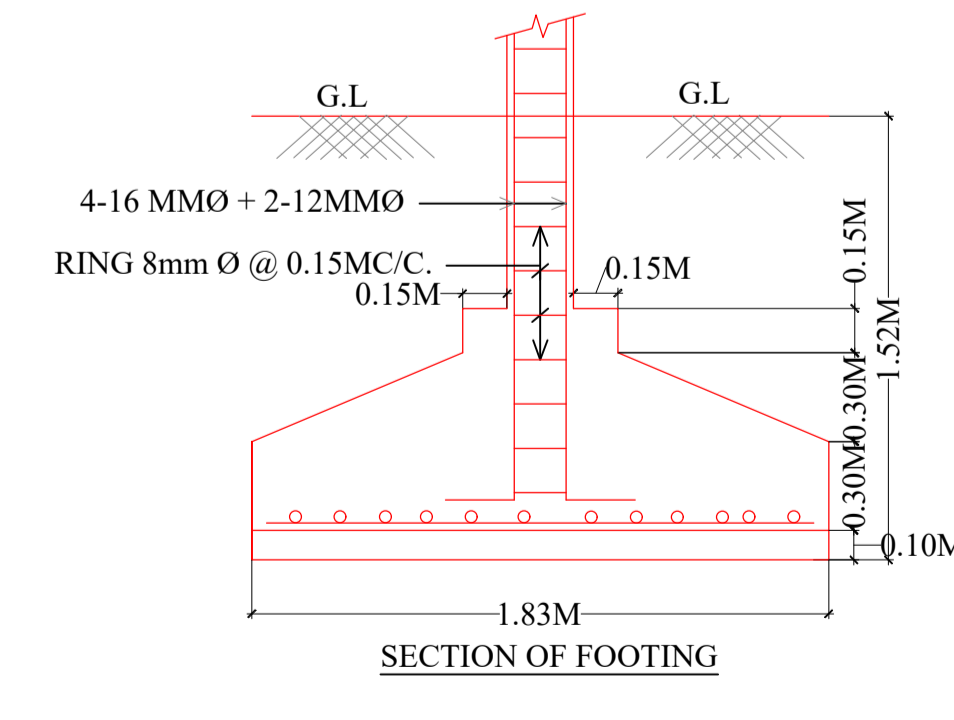
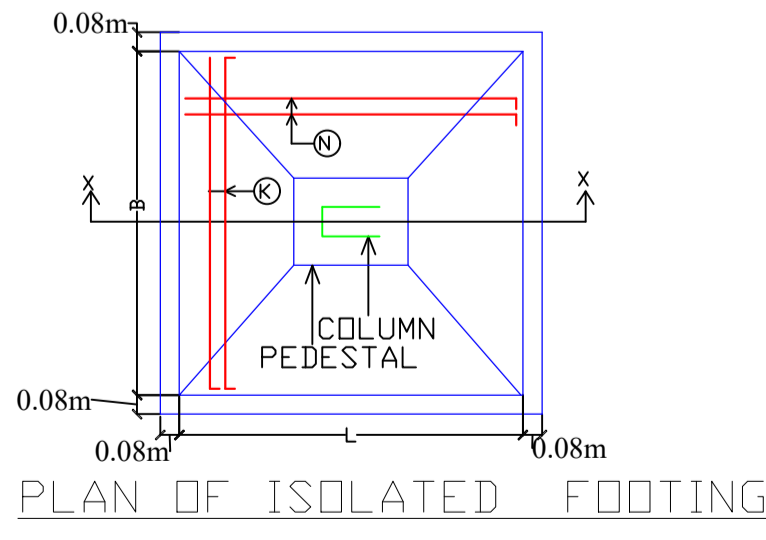
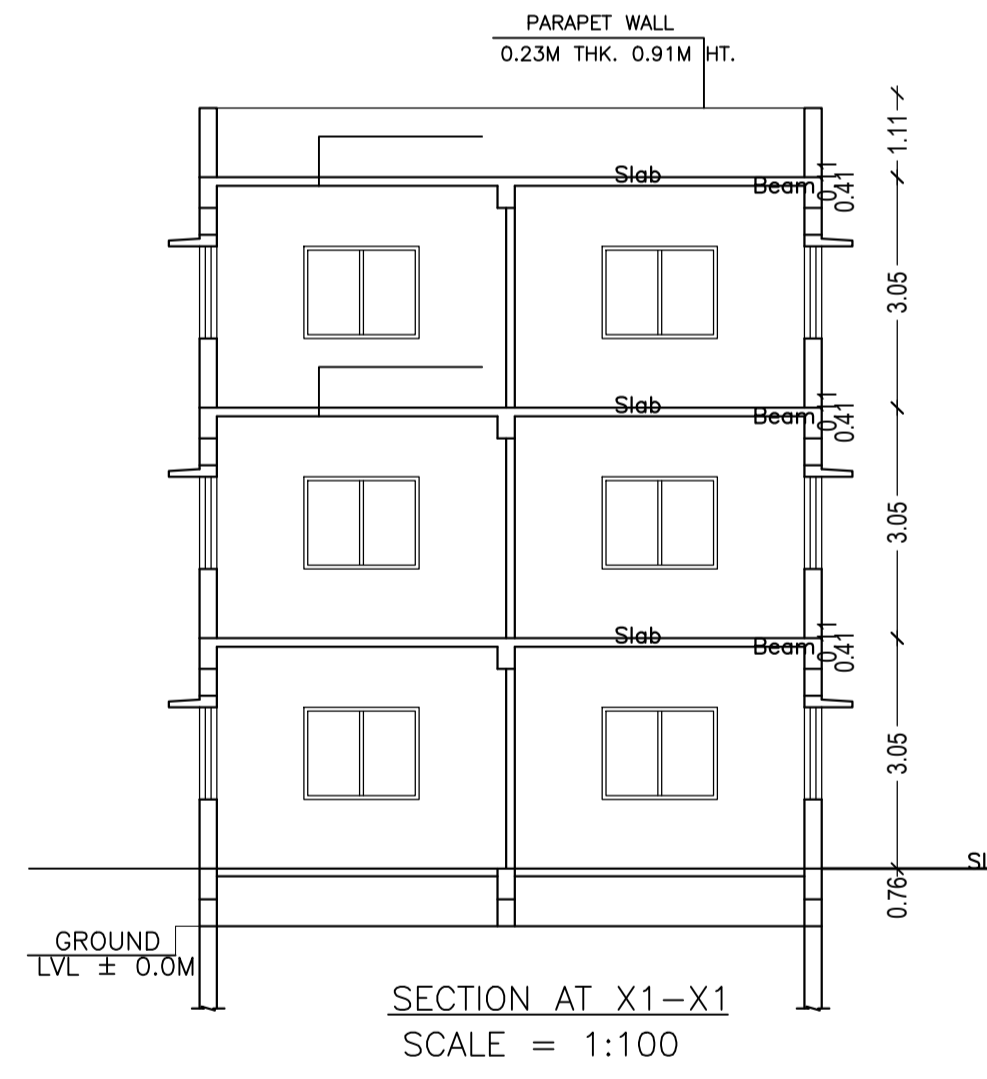
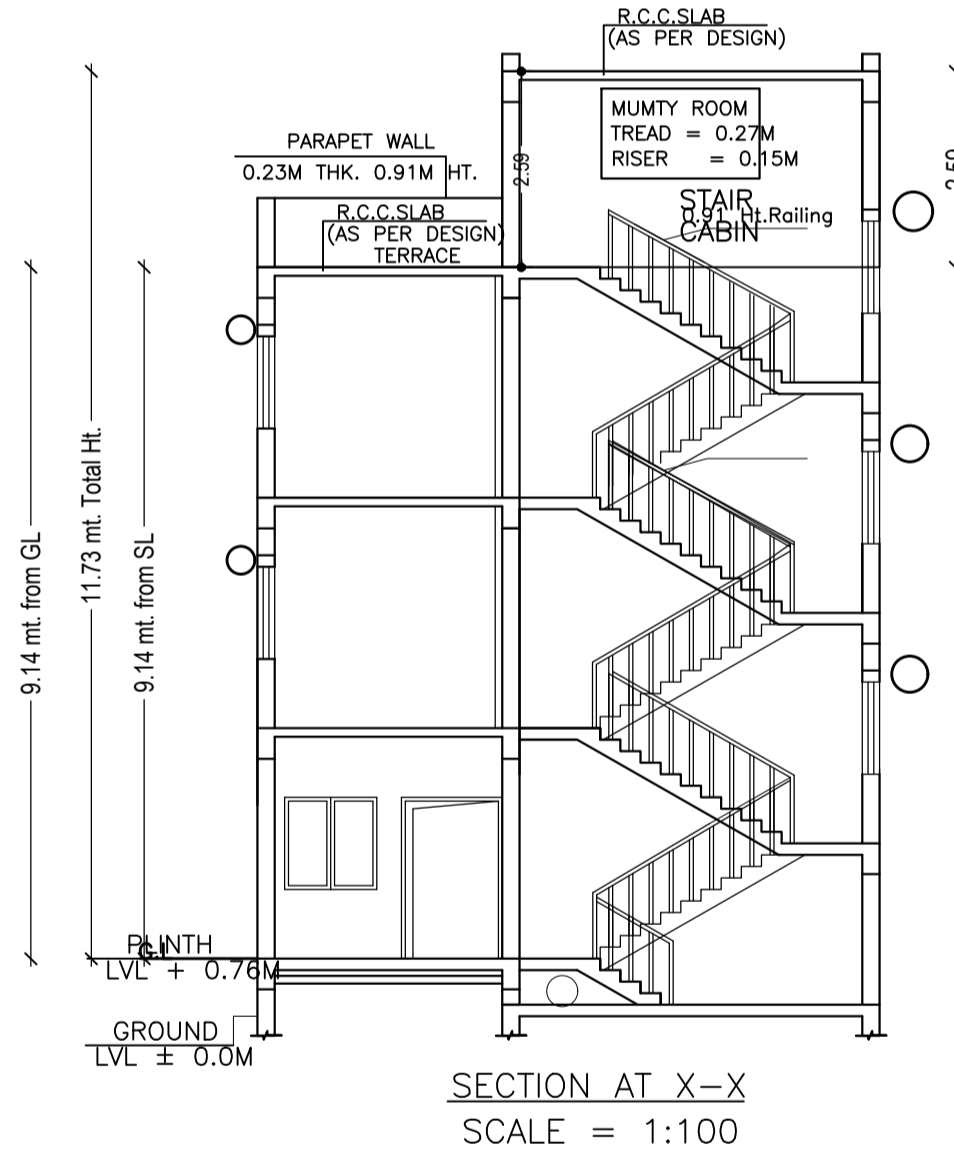
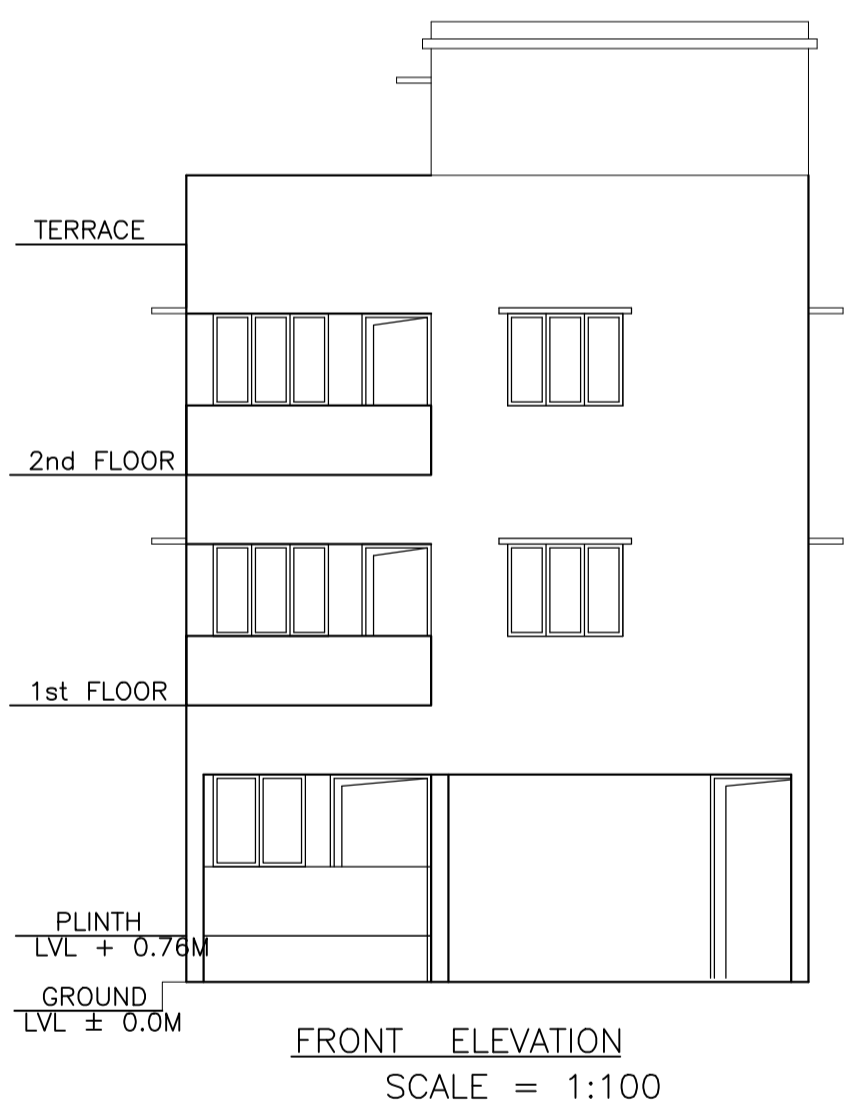

Building :A (RESIDENTIAL)

Floor Name	Total Built Up Area (Sq.mt.)	Deductions (Area in Sq.mt.)	Proposed FAR Area (Sq.mt.)	Total FAR Area (Sq.mt.)	Total Consumed Additional FAR Area (Sq.mt.)	Trmt (No.)
Ground Floor	117.37	44.52	72.85	72.85	0.00	01
First Floor	117.37	0.00	117.37	117.37	117.37	00
Second Floor	117.37	0.00	117.37	117.37	117.37	00
Terrace Floor	0.00	0.00	0.00	0.00	0.00	00
Total :	352.11	44.52	307.59	307.59	307.59	01
Total Number of Same Buildings	1					
Total :	352.11	44.52	307.59	307.59	307.59	01

Proposal Basic Information

Proposal File No.	AMC/BP/0015/W17/2022
Owner Name	SHREE AMIT KUMAR
Khata No	178
Plot No	1620(P), 1621(P)
Village Name	KULUPTANGA
Use	Residential
SubUse	Bungalow/ Dwelling / Non Apartment

AREA STATEMENT ADITYAPUR MUNICIPAL CORPORATION

VERSION NO.: 1.0.62
VERSION DATE: 16/10/2020

PROJECT DETAIL:

Region: JHARKHAND URBAN LOCAL BODIES	Plot Use: Residential
District: EAST SINGBHMUM	Plot SubUse: Bungalow/ Dwelling / Non Apartment
Authority: ADITYAPUR MUNICIPAL CORPORATION	PlotNearbyReligiousStructure: NA
Inward No: AMC/BP/0015/W17/2022	Plot/SubPlot No: 1620(P), 1621(P)
Application Type: General Proposal	North: Road Width - 1594(p)
Project Type: Building Permission	South: Road Width - 6.10
Nature of Development: New	East: Plot No. - 1621(p), 1620(p), 1594(p)
Location of Development Area: Old Area	West: Plot No. - 1620(p), 1621(p), 1594(p)

AREA DETAILS:

AREA OF PLOT (Minimum)	(A)	SQ.MT.
NET AREA OF PLOT (Gross Plot Area - Deduction from Gross Plot area)	(A-Deductions)	183.95
Deduction for Balance Plot Area (from Gross Plot Area)		
Common Plot		12.73
Total		12.73
BALANCE AREA OF PLOT (Net Plot Area - Recreational/Amenity space)	(A-Deductions)	171.22
PLOT AREA FOR COVERAGE (Net Plot Area)	(A-Deductions)	183.95
Plot Area for FAR (Net Plot Area + Road Widening Area)	(A-Deductions)	183.95
COVERAGE CHECK		
Permissible Coverage area (70.00 %)		128.76
Proposed Coverage Area (63.81 %)		117.37
Total Prop. Coverage Area (63.81 %)		117.37
Balance coverage area (6.19 %)		11.39
FAR CHECK		
Perm. FAR Area (2.50)		459.88
Total Perm. FAR area		459.88
Residential FAR		307.59
Proposed FAR Area		307.59
Total Proposed FAR Area		307.59
Consumed FAR (Factor)		1.67
Balance FAR Area		152.29
BUILT UP AREA CHECK		
Total Proposed BuiltUp Area		352.11
ARCHITECT (Regd)	WALEED ANWAR	
ENGINEER (Regd)		
SUPERVISOR (Regd)		
OWNER (Regd)	SHREE AMIT KUMAR	
DEVELOPMENT AUTHORITY LOCAL BODY		

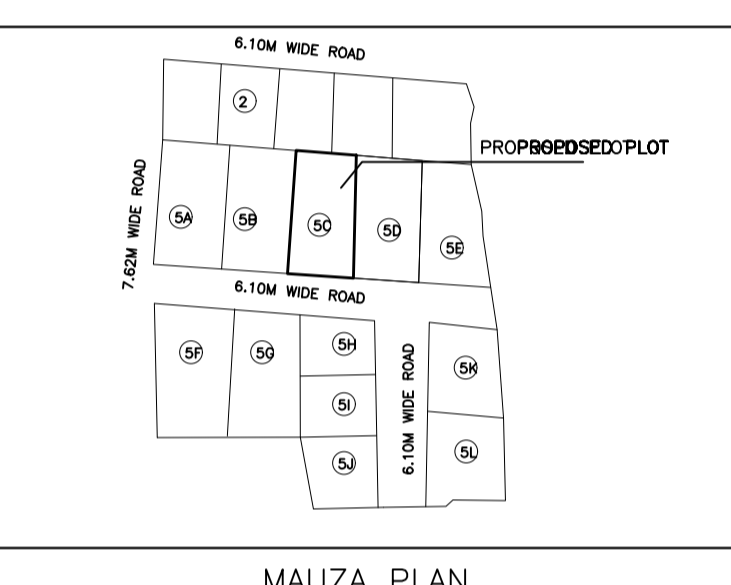
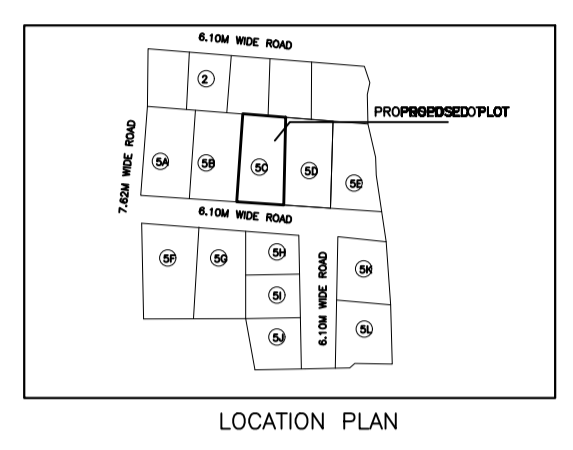

COLOR INDEX

PLOT BOUNDARY	Red
ABUTTING ROAD	Green
PROPOSED CONSTRUCTION	Blue
COMMON PLOT	Yellow
ROAD WIDENING AREA	Orange
EXISTING (To be retained)	Grey
EXISTING (To be demolished)	White

Buildingwise Floor FAR Details

Floor Name	Building Name		Total	
	Proposed Built Up Area (Sq.mt.)	Proposed FAR Area (Sq.mt.)	Total Proposed Built Up Area (Sq.mt.)	Total FAR Area (Sq.mt.)
Ground Floor	117.37	72.85	117.37	72.85
First Floor	117.37	117.37	117.37	117.37
Second Floor	117.37	117.37	117.37	117.37
Terrace Floor	0.00	0.00	0.00	0.00
Total :	352.11	307.59	352.11	307.59

Building USE/SUBUSE Details

Building Name	Building Use	Building SubUse	Building Structure
A (RESIDENTIAL)	Residential	Bungalow/ Dwelling / Non Apartment	Non-Highrise

FAR & Tenement Details (Table 4c-1)

Building	No. of Same Bldg	Total Built Up Area (Sq.mt.)	Deductions (Area in Sq.mt.)	Proposed FAR Area (Sq.mt.)	Total FAR Area (Sq.mt.)	Total Consumed Additional FAR Area (Sq.mt.)	Trmt (No.)
Grand Total :	1	352.11	44.52	307.59	307.59	307.59	01

SCHEDULE OF DOOR:

BUILDING NAME	NAME	LENGTH	HEIGHT	NOS
A (RESIDENTIAL)	D2	0.76	2.10	04
A (RESIDENTIAL)	D1	0.84	2.10	02
A (RESIDENTIAL)	D2	0.84	2.10	01
A (RESIDENTIAL)	D1	0.90	2.10	10
A (RESIDENTIAL)	D	1.05	2.10	03
A (RESIDENTIAL)	D	1.33	2.10	01

SCHEDULE OF WINDOW/VENTILATION:

BUILDING NAME	NAME	LENGTH	HEIGHT	NOS
A (RESIDENTIAL)	V	0.61	1.20	05
A (RESIDENTIAL)	W2	1.22	1.20	01
A (RESIDENTIAL)	W1	1.52	1.20	23

UnitBUA Table for Building :A (RESIDENTIAL)

FLOOR	Name	UnitBUA Type	UnitBUA Area	Carpet Area	No. of Rooms	No. of Tenement
GROUND FLOOR PLAN	SPLIT 1	FLAT	246.92	245.60	5	1
SECOND FLOOR PLAN	SPLIT 1	FLAT	0.00	0.00	9	0
FIRST FLOOR PLAN	SPLIT 1	FLAT	0.00	0.00	9	0
Total:	-	-	246.92	245.60	23	1

LTP NAME AND SIGNATURE	STRUCTURAL ENG'S NAME AND SIGNATURE	BUILDER NAME AND SIGNATURE	DIGITAL SIGNATURE
WALEED ANWAR AMC/SUP/0005/2021			