

Proposal Basic Information

Proposal File No.	AMC/BP/0059/W22/2022
Owner Name	TECHNOCULTURE BUILDING CENTRE PRIVATE LIMITED
Khata No	190,403
Plot No	429,2401
Village Name	ASANGI
Use	Residential
SubUse	Bungalow/ Dwelling / Non Apartment

AREA STATEMENT

ADITYAPUR MUNICIPAL CORPORATION	VERSION NO: 1.0.62	SQ.MT.
PROJECT DETAIL:	VERSION DATE: 16/10/2020	
Region: JHARKHAND URBAN LOCAL BODIES	Plot Use: Residential	
District: EAST SINGBHUM	Plot SubUse: Bungalow/ Dwelling / Non Apartment	
Authority: ADITYAPUR MUNICIPAL CORPORATION	PlotNearbyReligiousStructure: NA	
Inward No: AMC/BP/0059/W22/2022	PlotSubPlot No: 429,2401	
Application Type: General Proposal	North: -	
Project Type: Building Permission	South: -	
Nature of Development: New	East: -	
Location of Development Area: Old Area	West: -	

AREA OF PLOT (Minimum)	(A)	75.24
NET AREA OF PLOT (Gross Plot Area - Deduction from Gross Plot area)	(A-Deductions)	75.24
Deduction for Balance Plot Area (from Gross Plot Area)		
Common Plot		5.30
Total		5.30
BALANCE AREA OF PLOT (Net Plot Area - Recreational/Amenity space)	(A-Deductions)	69.94
PLOT AREA FOR COVERAGE (Net Plot Area)	(A-Deductions)	75.24
Plot Area for FAR (Net Plot Area + Road Widening Area)	(A-Deductions)	75.24

COVERAGE CHECK		
Permissible Coverage area (70.00 %)		52.67
Proposed Coverage Area (59.86 %)		45.04
Total Prop. Coverage Area (59.86 %)		45.04
Balance coverage area (10.14 %)		7.63
FAR CHECK		
Perm. FAR Area (2.50)		188.10
Total Perm. FAR area		188.10
Residential FAR		93.54
Proposed FAR		93.54
Total Proposed FAR Area		93.54
Consumed FAR (Factor)		1.24
Balance FAR Area		94.56

BUILT UP AREA CHECK		
Total Proposed BuiltUp Area		93.55
ARCHITECT (Regd)	MOHAMMAD BELAL NASIR	
ENGINEER (Regd)		
SUPERVISOR (Regd)		
OWNER (Regd)	TECHNOCULTURE BUILDING CENTRE PRIVATE LIMITED	
DEVELOPMENT AUTHORITY		LOCAL BODY

COLOR INDEX	
PLOT BOUNDARY	Black
ABUTTING ROAD	Green
PROPOSED CONSTRUCTION	Red
COMMON PLOT	Yellow
ROAD WIDENING AREA	Blue
EXISTING (To be retained)	Light Blue
EXISTING (To be demolished)	Light Yellow

Buildingwise Floor FAR Details				
Floor Name	Building Name		Total	
	Proposed Built Up Area (Sq.mt.)	Proposed FAR Area (Sq.mt.)	Total Proposed Built Up Area (Sq.mt.)	Total FAR Area (Sq.mt.)
Ground Floor	45.04	45.04	45.04	45.04
First Floor	48.51	48.51	48.51	48.51
Terrace Floor	0.00	0.00	0.00	0.00
Total :	93.55	93.55	93.55	93.55

Building USE/SUBUSE Details			
Building Name	Building Use	Building SubUse	Building Structure
A(TBCPL)	Residential	Residential Bldg/Apartment	Non-Highrise

Building :A(TBCPL)					
Floor Name	Total Built Up Area (Sq.mt.)	Proposed FAR Area (Sq.mt.)	Total FAR Area (Sq.mt.)	Total Consumed Additional FAR Area (Sq.mt.)	Tnmt (No.)
Ground Floor	45.04	45.04	45.04	45.04	01
First Floor	48.51	48.51	48.51	48.51	00
Terrace Floor	0.00	0.00	0.00	0.00	00
Total :	93.55	93.55	93.55	93.55	01
Total Number of Same Buildings :	1				
Total :	93.55	93.55	93.55	93.55	01

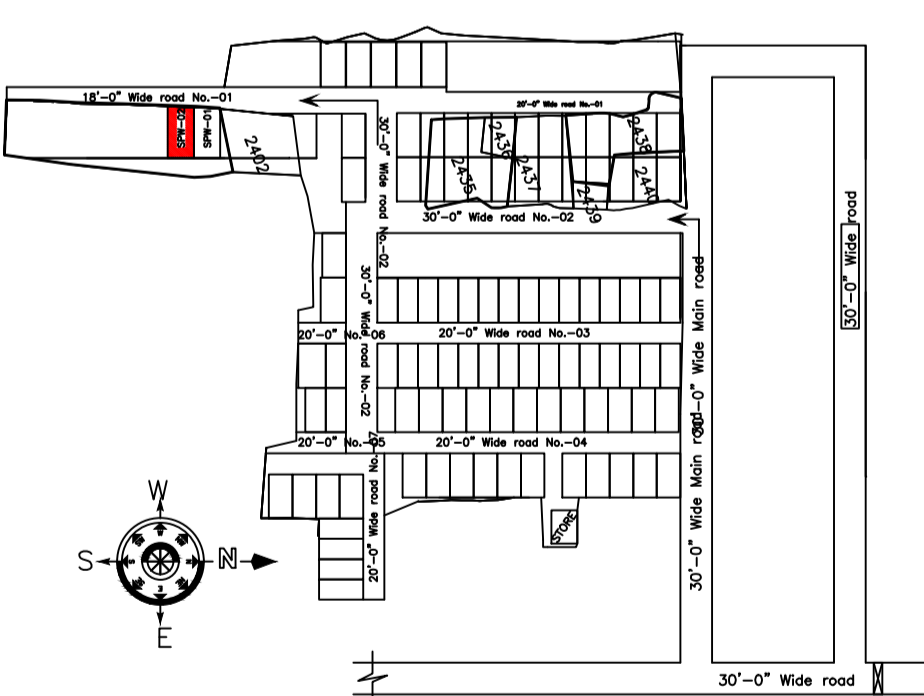
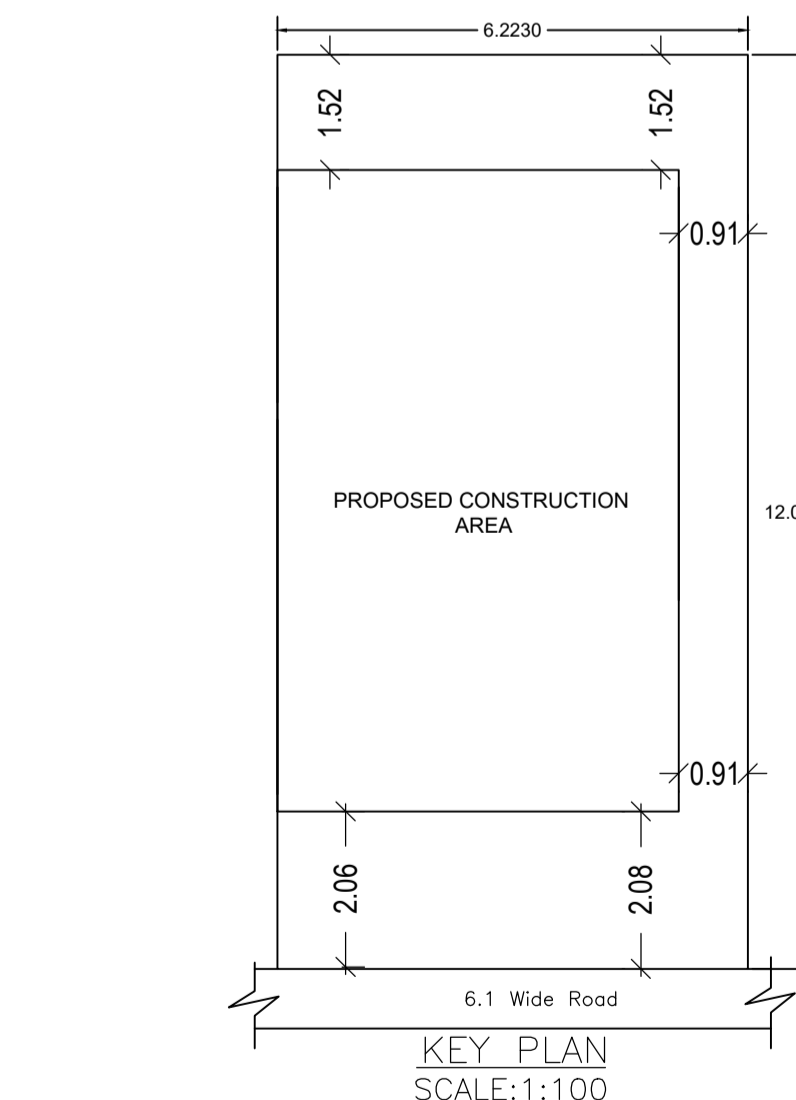
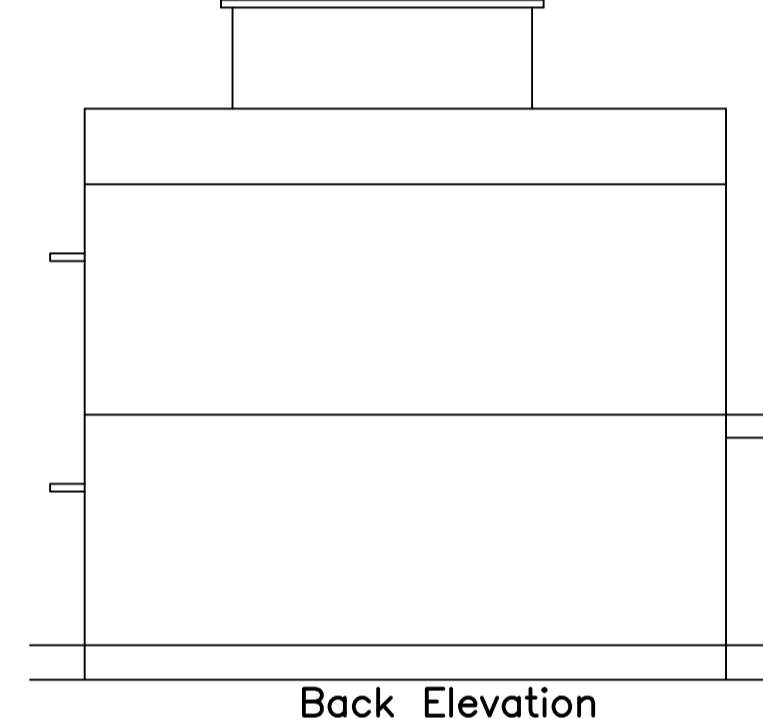
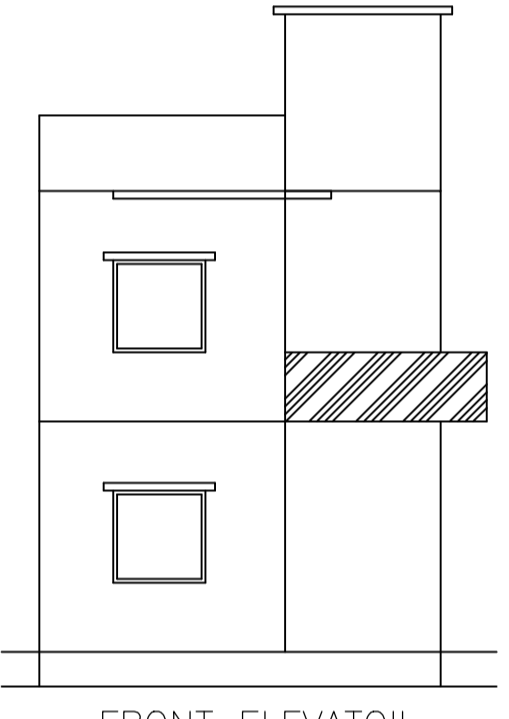
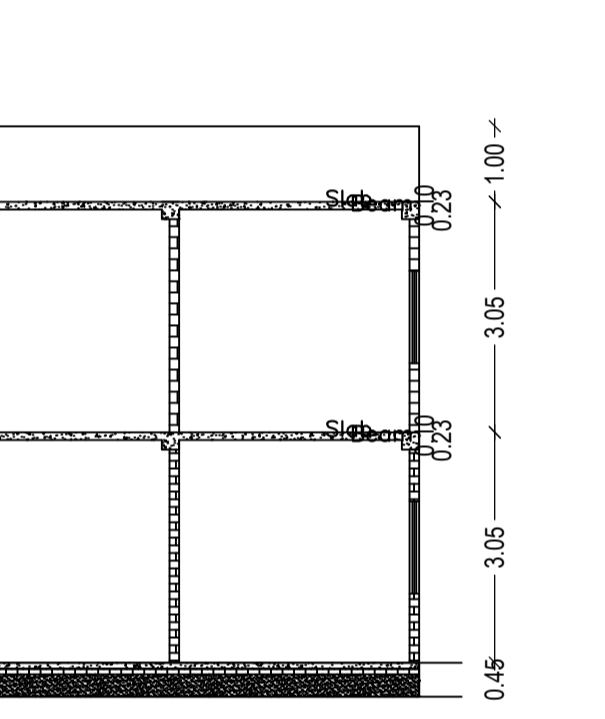
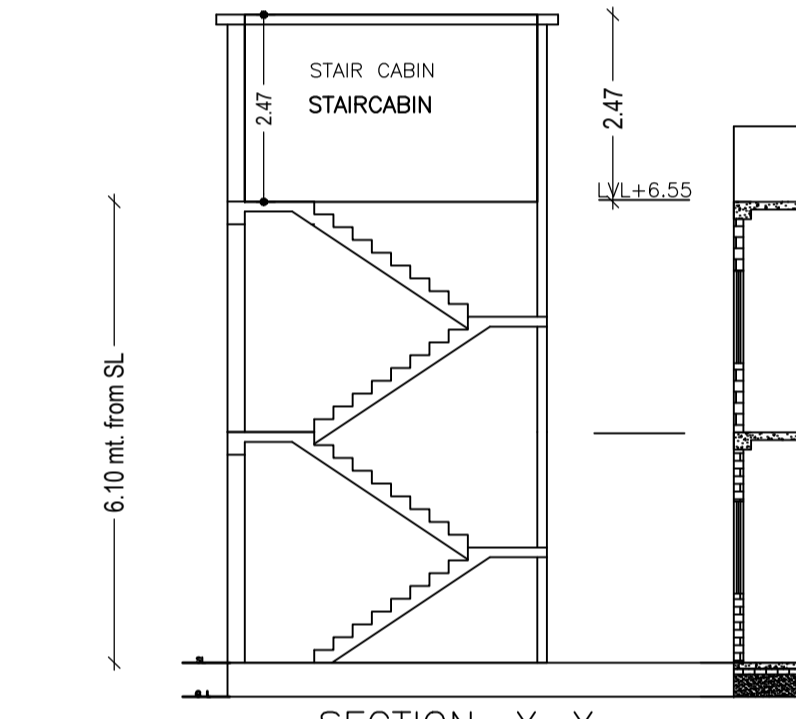
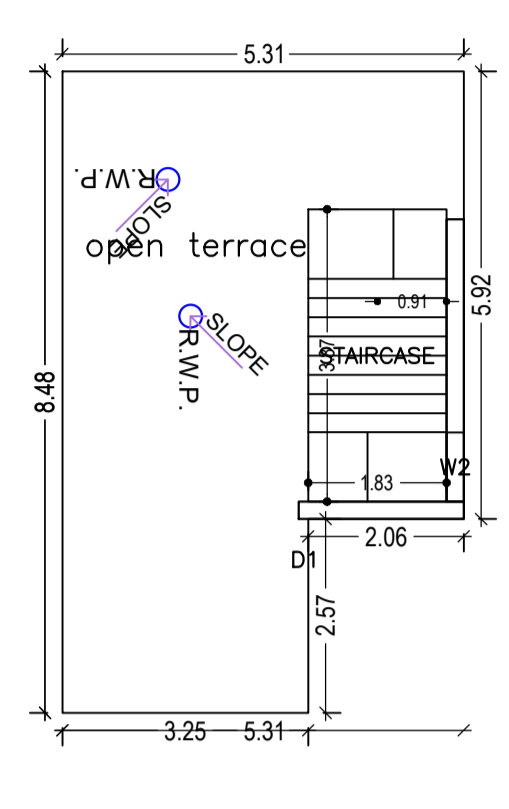
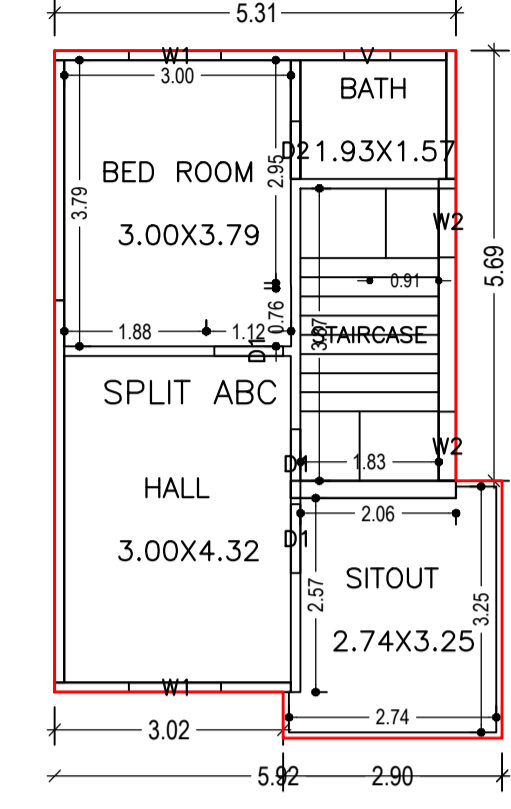
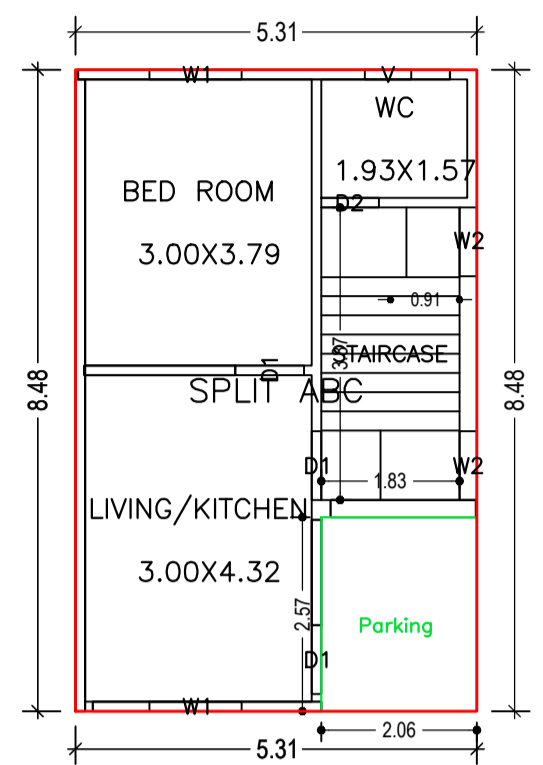
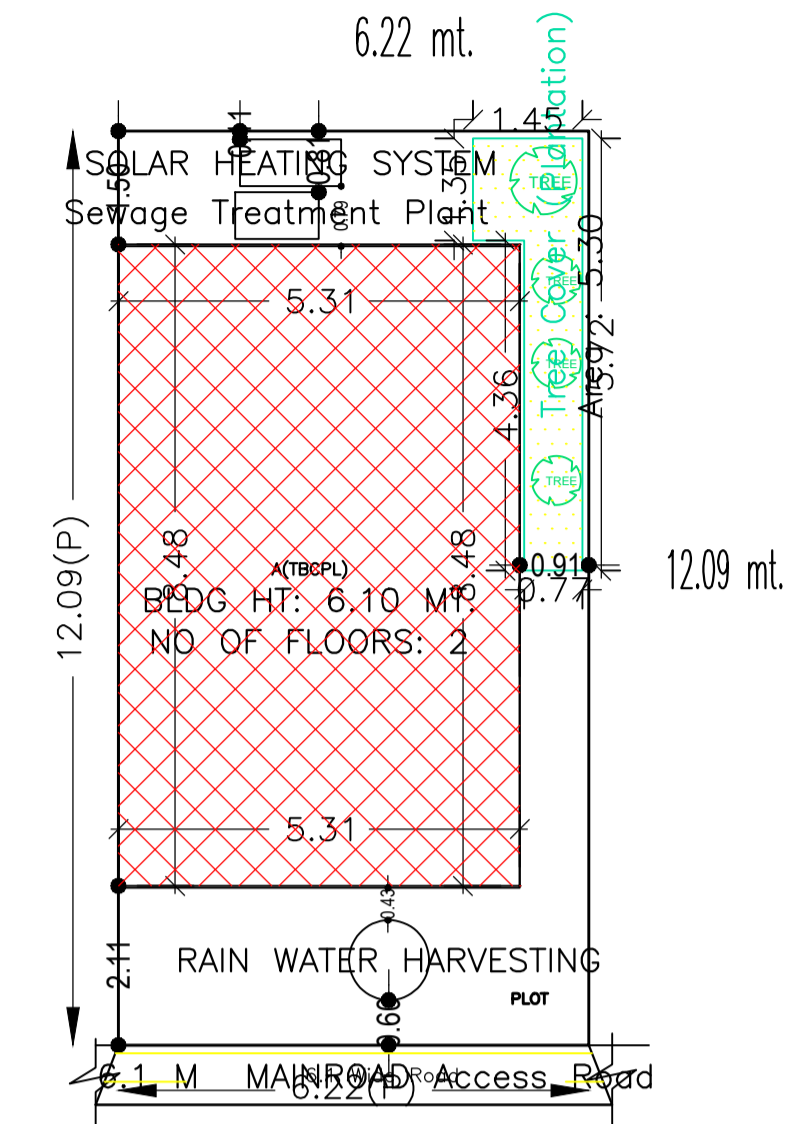
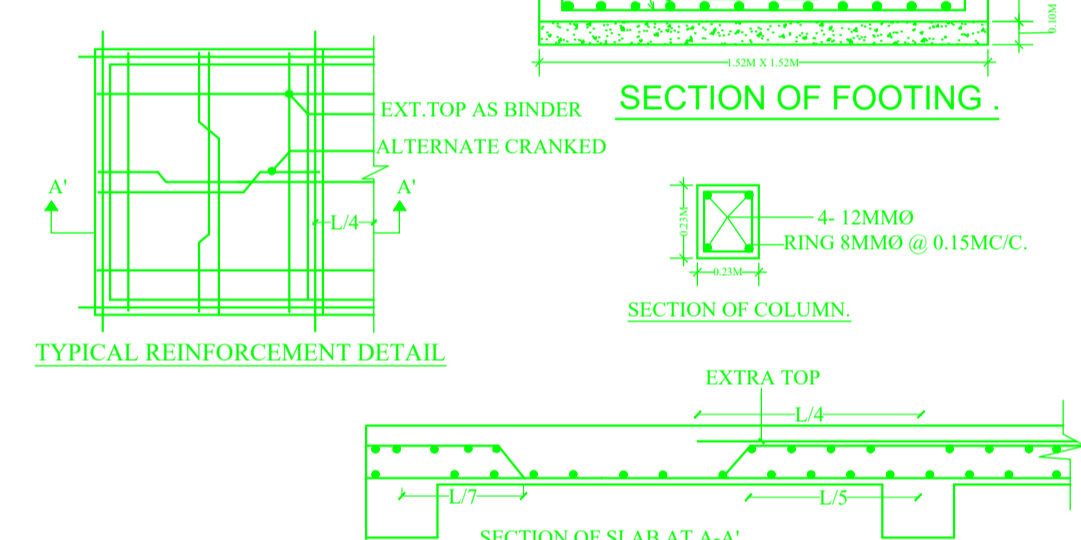
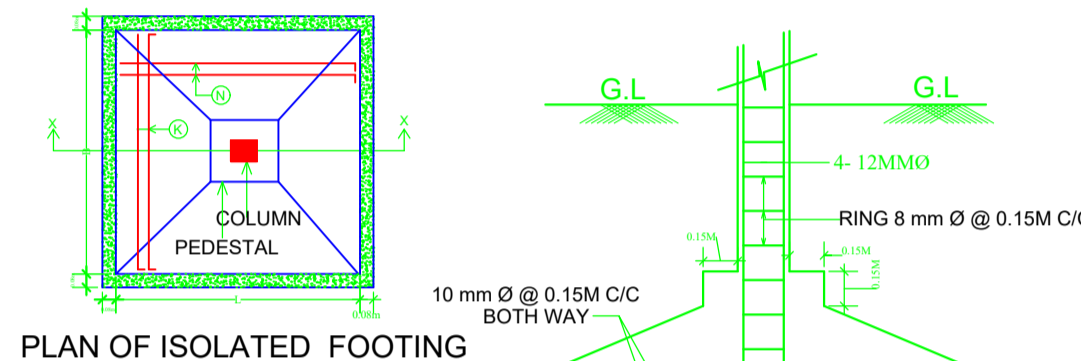
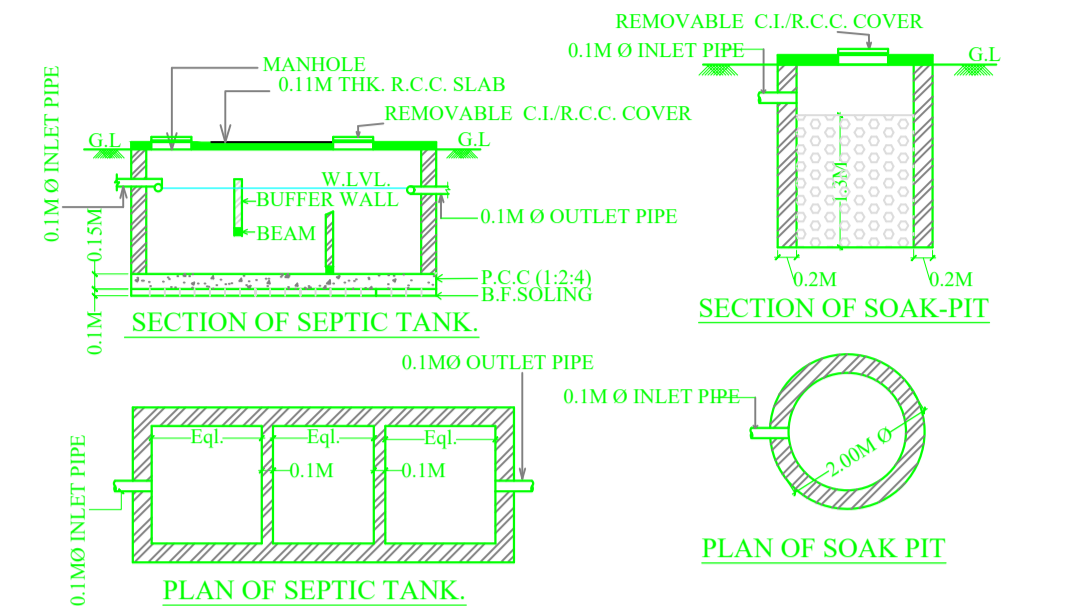

SCHEDULE OF DOOR:

BUILDING NAME	NAME	LENGTH	HEIGHT	NOS
A(TBCPL)	D2	0.76	2.13	02
A(TBCPL)	D1	0.91	2.13	06

SCHEDULE OF WINDOW/VENTILATION:

BUILDING NAME	NAME	LENGTH	HEIGHT	NOS
A(TBCPL)	V	0.61	0.61	02
A(TBCPL)	W2	0.91	1.22	05
A(TBCPL)	W1	1.22	1.22	04

UnitBUA Table for Building :A(TBCPL)

FLOOR	Name	UnitBUA Type	UnitBUA Area	Carpet Area	No. of Rooms	No. of Tenement
GROUND FLOOR PLAN	SPLIT ABC	FLAT	87.71	80.84	3	1
FIRST FLOOR PLAN	SPLIT ABC	FLAT	0.00	0.00	4	0
Total:	-	-	87.71	80.84	7	1

FAR & Tenement Details (Table 4c-1)

Building	No. of Same Bldg	Total Built Up Area (Sq.mt.)	Proposed FAR Area (Sq.mt.)	Total FAR Area (Sq.mt.)	Total Consumed Additional FAR Area (Sq.mt.)	Tnmt (No.)
A(TBCPL)	1	93.55	93.55	93.55	93.55	01
Grand Total :	1	93.55	93.55	93.55	93.55	01

LTP NAME AND SIGNATURE	STRUCTURAL ENG'S NAME AND SIGNATURE	BUILDER NAME AND SIGNATURE	DIGITAL SIGNATURE
MOHAMMAD BELAL NASIR AMC/ENG/0015/2017			