

SCHEDULE OF DOOR:

BUILDING NAME	NAME	LENGTH	HEIGHT	NOS
A (RESIDENTIAL)	D2	0.75	2.10	04
A (RESIDENTIAL)	D1	0.90	2.10	10
A (RESIDENTIAL)	D	1.05	2.10	02

SCHEDULE OF WINDOW/VENTILATION:

BUILDING NAME	NAME	LENGTH	HEIGHT	NOS
A (RESIDENTIAL)	V	0.60	1.20	04
A (RESIDENTIAL)	W2	0.91	1.20	02
A (RESIDENTIAL)	Wk	1.22	1.20	01
A (RESIDENTIAL)	W1	1.52	1.20	16
A (RESIDENTIAL)	Wk	1.52	1.20	01

Proposal Basic Information

Proposal File No.	AMC/BP/0004/W03/2023
Owner Name	SUVENDU SEN
Khata No	172(N),23(O)
Plot No	164(n), 1948(n)
Village Name	BURKADIH
Use	Residential
SubUse	Bungalow/ Dwelling / Non Apartment

UnitBUA Table for Building :A (RESIDENTIAL)

FLOOR	Name	UnitBUA Type	UnitBUA Area	Carpet Area	No. of Rooms	No. of Tenement
GROUND FLOOR PLAN	SPLIT 1	FLAT	175.11	174.76	7	1
FIRST FLOOR PLAN	SPLIT 1	FLAT	0.00	0.00	12	0
Total	-	-	175.11	174.76	19	1



AREA STATEMENT
ADITYAPUR MUNICIPAL CORPORATION

VERSION NO.	VERSION DATE
1.0.65	16/10/2020

PROJECT DETAIL:

Region: JHARRKHAND URBAN LOCAL BODIES	Plot Use: Residential
District: EAST SINGBHM	Plot SubUse: Bungalow/ Dwelling / Non Apartment
Authority: ADITYAPUR MUNICIPAL CORPORATION	PlotNearby/ReligiousStructure: NA
Inward No: AMC/BP/0004/W03/2023	Plot/SubPlot No: 164(n), 1948(n)
Application Type: General Proposal	North: Plot No. - sub plot no.66
Project Type: Building Permission	South: Road Width - 6.10
Nature of Development: New	East: Plot No. - sub plot no. 90
Location of Development Area: Old Area	West: Plot No. - sub no. 88

AREA DETAILS:

AREA OF PLOT (Minimum)	SQ.MT.
(A)	222.60
NET AREA OF PLOT(Gross Plot Area - Deduction from Gross Plot area)	222.60
Deduction for Balance Plot Area(from Gross Plot Area)	
Common Plot	13.58
Total	13.58
BALANCE AREA OF PLOT(Net Plot Area - Recreational/Amenity space)	(A-Deductions) 209.02
PLOT AREA FOR COVERAGE(Net Plot Area)	(A-Deductions) 222.60
Plot Area for FAR (Net Plot Area + Road Widening Area)	(A-Deductions) 222.60

COVERAGE CHECK

Permissible Coverage area (70.00 %)	155.82
Proposed Coverage Area (61.21 %)	136.26
Total Prop. Coverage Area (61.21 %)	136.26
Balance coverage area (8.79 %)	19.56

FAR CHECK

Perm. FAR Area (2.500)	556.50
Total Perm. FAR area	556.50
Residential FAR	216.87
Proposed FAR Area	216.87
Total Proposed FAR Area	216.87
Consumed FAR (Factor)	0.97
Balance FAR Area	339.63

BUILT UP AREA CHECK

Total Proposed BuiltUp Area	272.52
ARCHITECT (Regd)	WALEED ANWAR
ENGINEER (Regd)	
SUPERVISOR (Regd)	
OWNER (Regd)	SUVENDU SEN

DEVELOPMENT AUTHORITY LOCAL BODY

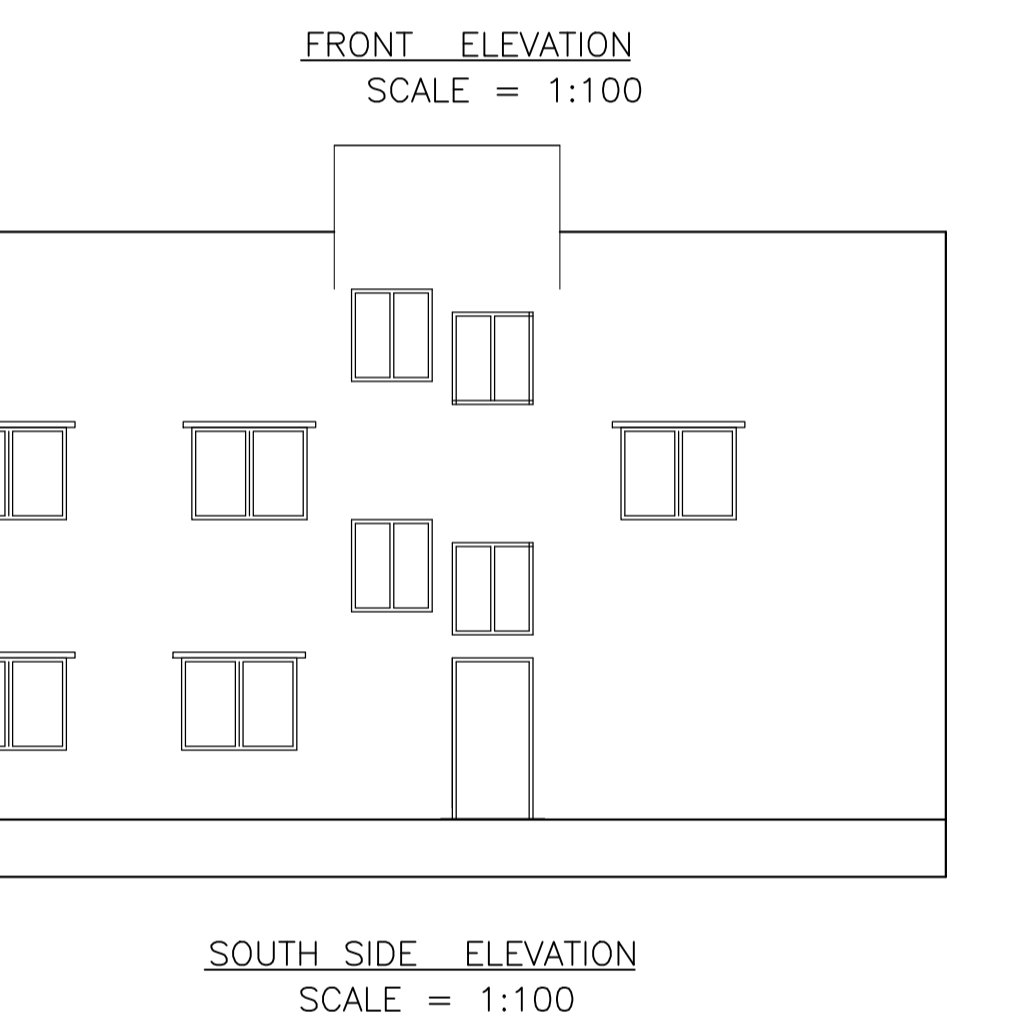
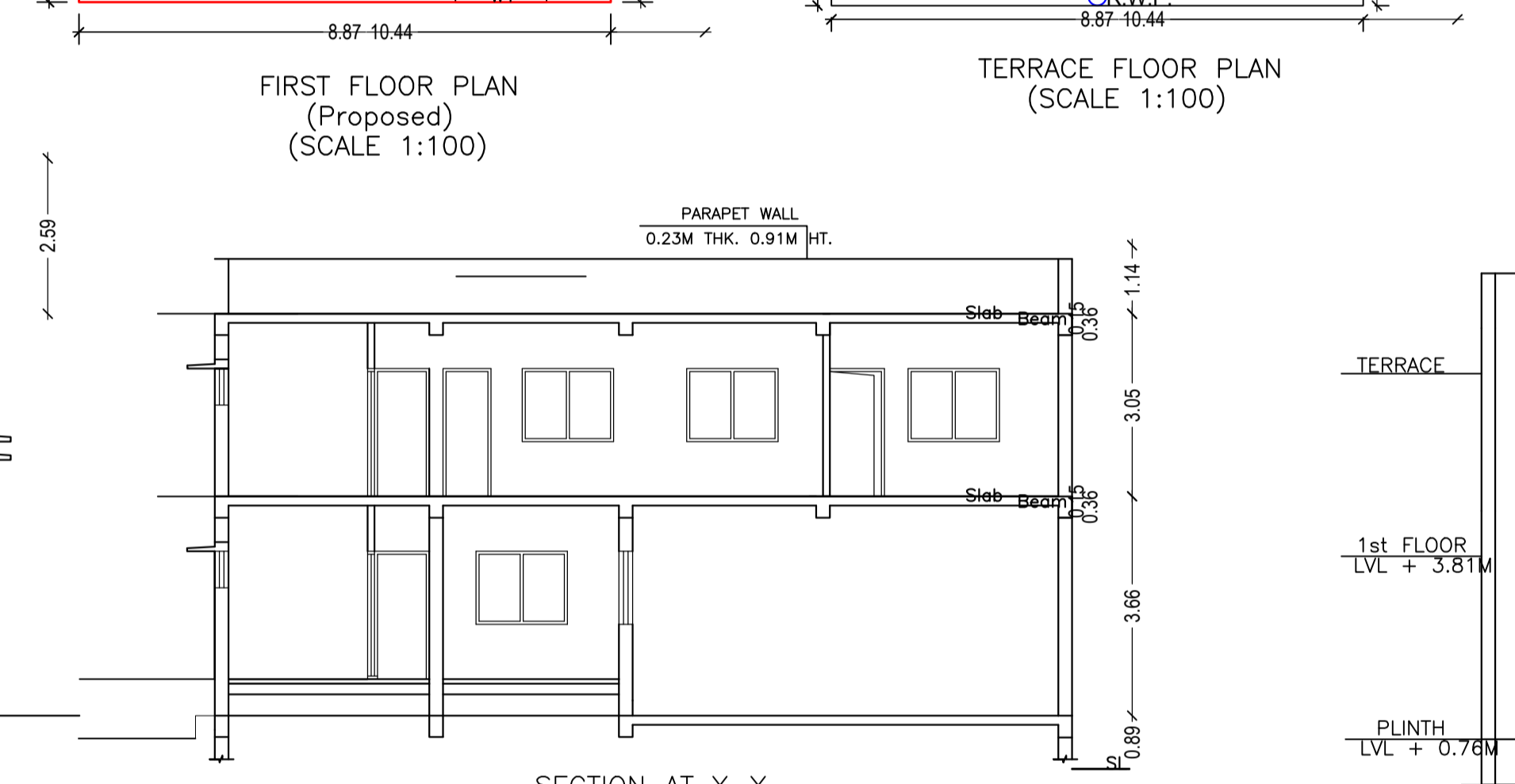
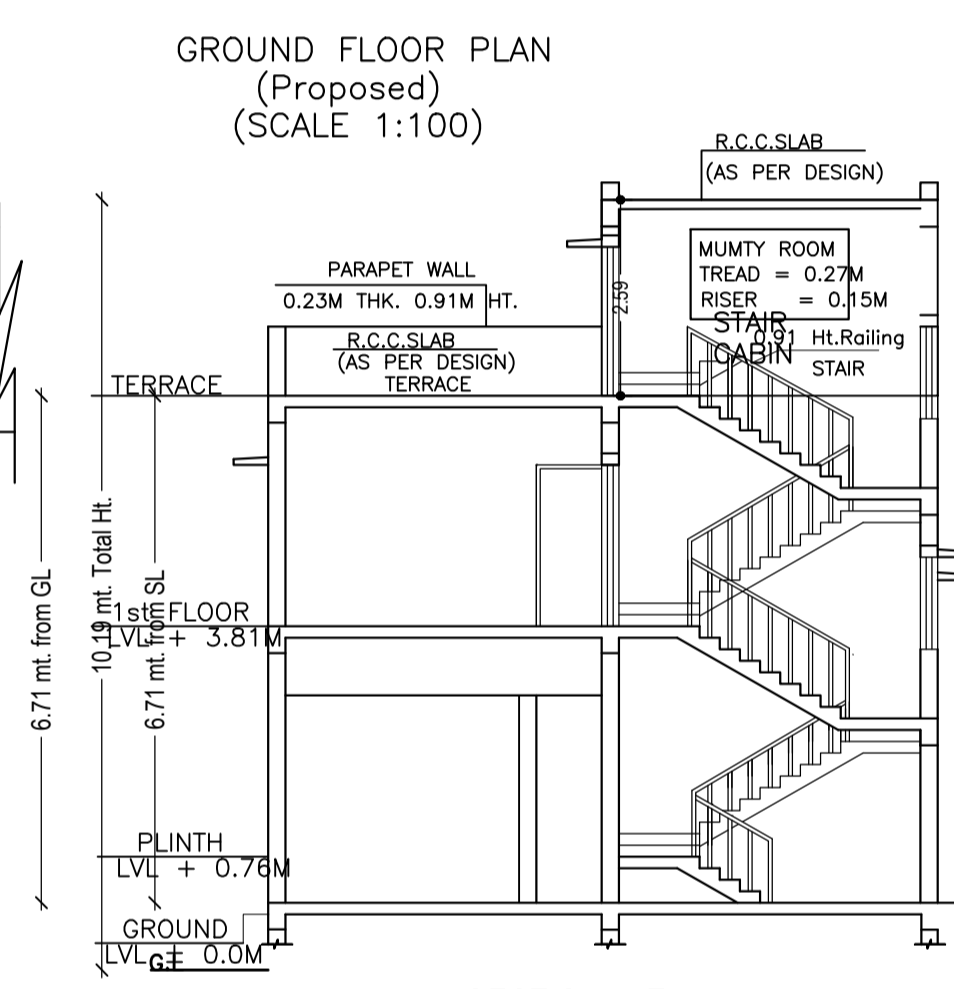
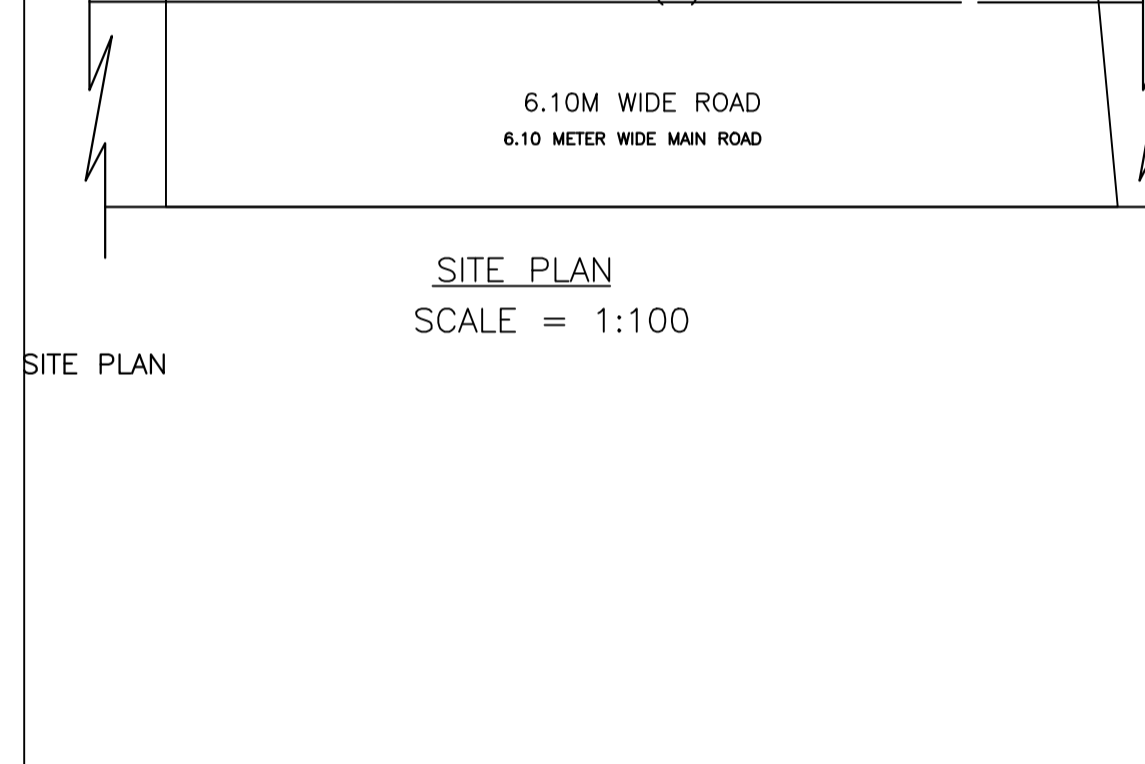

COLOR INDEX

PLOT BOUNDARY	Red
ABUTTING ROAD	Green
PROPOSED CONSTRUCTION	Yellow
COMMON PLOT	Orange
ROAD WIDENING AREA	Blue
EXISTING (To be retained)	Light Blue
EXISTING (To be demolished)	Dark Blue

Buildingwise Floor FAR Details

Floor Name	Building Name A (RESIDENTIAL)		Total	
	Proposed Built Up Area (Sq.mt.)	Proposed FAR Area (Sq.mt.)	Total Proposed Built Up Area (Sq.mt.)	Total FAR Area (Sq.mt.)
Ground Floor	136.26	80.61	136.26	80.61
First Floor	136.26	136.26	136.26	136.26
Terrace Floor	0.00	0.00	0.00	0.00
Total	272.52	216.87	272.52	216.87

Building USE/SUBUSE Details

Building Name	Building Use	Building SubUse	Building Structure
A (RESIDENTIAL)	Residential	Bungalow/ Dwelling / Non Apartment	Non-Highrise

FAR & Tenement Details (Table 4c-1)

Building	No. of Same Bldg	Total Built Up Area (Sq.mt.)	Deductions (Area in Sq.mt.)	Proposed FAR Area (Sq.mt.)		Total FAR Area (Sq.mt.)	Total Consumed Additional FAR Area (Sq.mt.)	Trmt (No.)
				Parking	Resi.			
A (RESIDENTIAL)	1	272.52	55.65	216.87	216.87	216.87	216.87	01
Grand Total:	1	272.52	55.65	216.87	216.87	216.87	216.87	01

Building :A (RESIDENTIAL)

Floor Name	Total Built Up Area (Sq.mt.)	Deductions (Area in Sq.mt.)	Proposed FAR Area (Sq.mt.)	Total FAR Area (Sq.mt.)	Total Consumed Additional FAR Area (Sq.mt.)	Trmt (No.)
Ground Floor	136.26	55.65	80.61	80.61	80.61	01
First Floor	136.26	0.00	136.26	136.26	136.26	00
Terrace Floor	0.00	0.00	0.00	0.00	0.00	00
Total:	272.52	55.65	216.87	216.87	216.87	01
Total Number of Same Buildings	1					
Total:	272.52	55.65	216.87	216.87	216.87	01

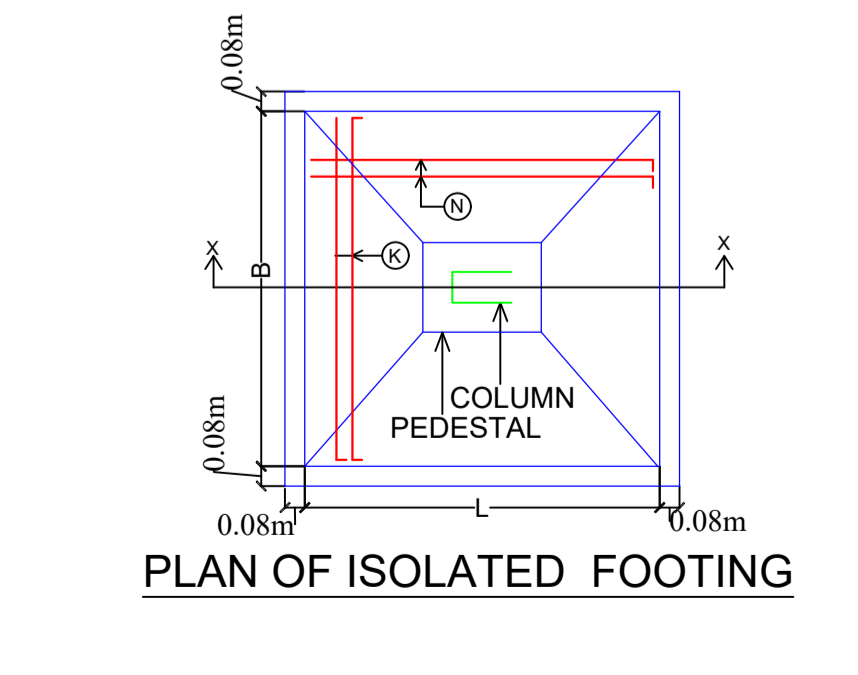
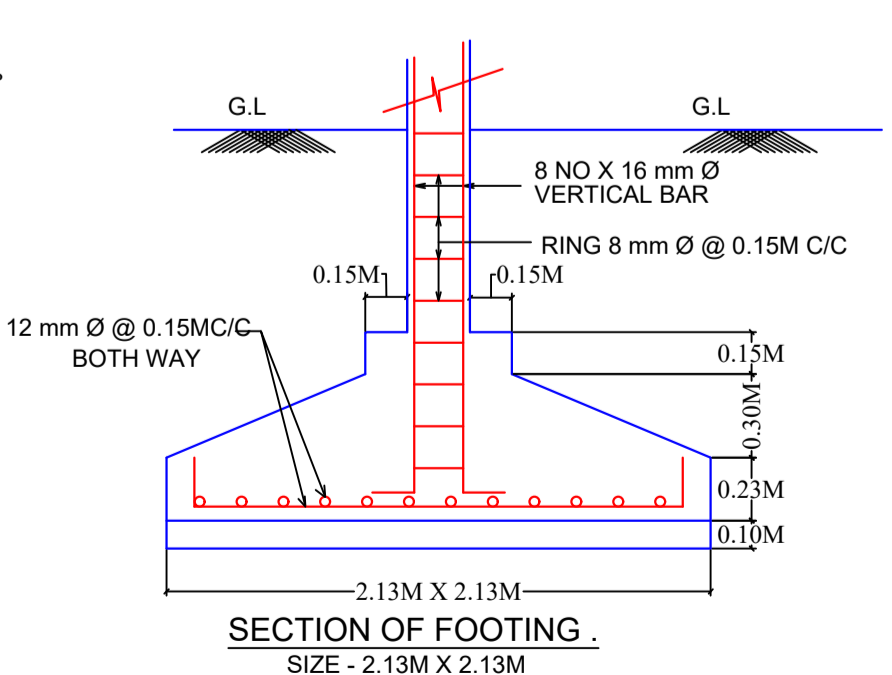
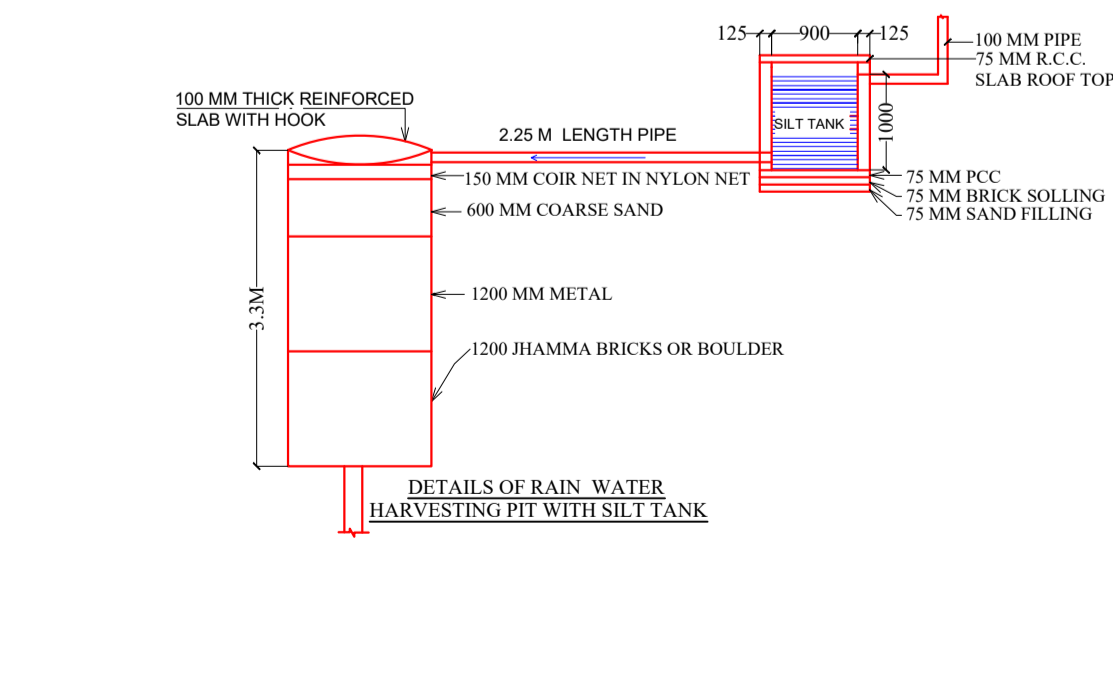
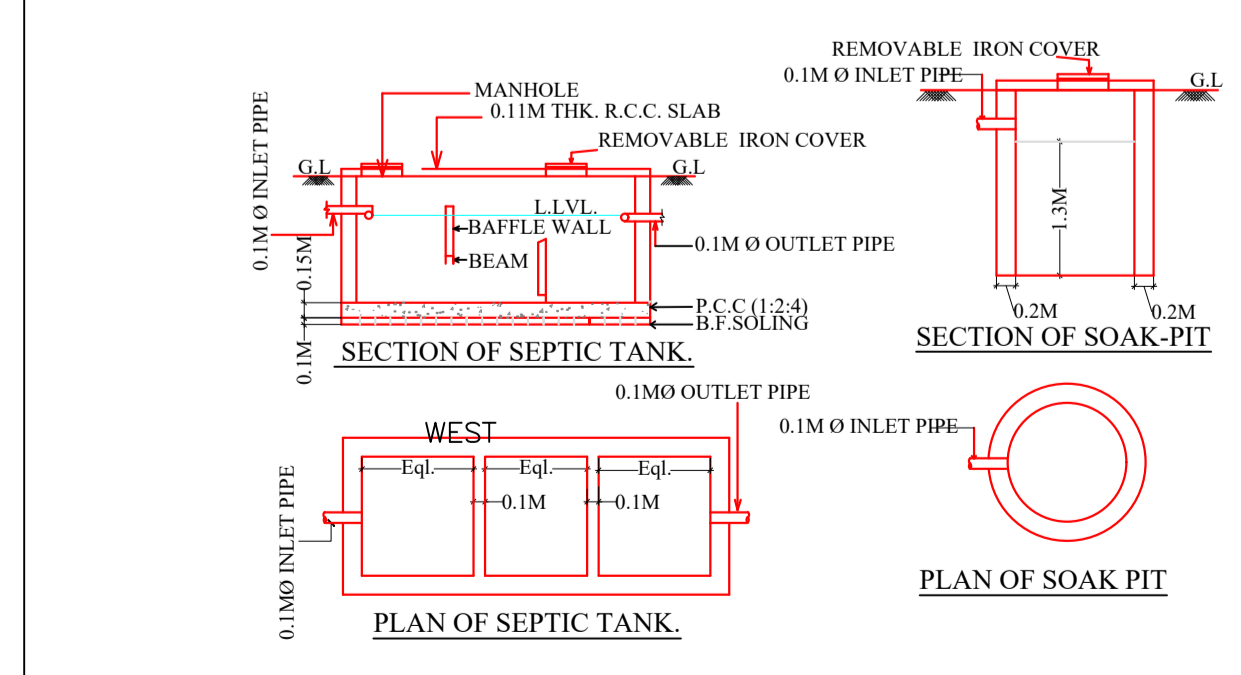

LTP NAME AND SIGNATURE	STRUCTURAL ENG'S NAME AND SIGNATURE	BUILDER NAME AND SIGNATURE	DIGITAL SIGNATURE
WALEED ANWAR AMC/SUP/0005/2021			

Proposal Basic Information

Proposal File No.	AMC/BP/0004/W03/2023
Owner Name	SUVENDU SEN
Khata No	172(N),23(O)
Plot No	164(o), 1948(n)
Village Name	BURKADIH
Use	Residential
SubUse	Bungalow/ Dwelling / Non Apartment

LTP NAME AND SIGNATURE	STRUCTURAL ENG'S NAME AND SIGNATURE	BUILDER NAME AND SIGNATURE	DIGITAL SIGNATURE
WALEED ANWAR AMC/SUP/0005/2021			