

Building :A (RESIDENTIAL)

Floor Name	Total Built Up Area (Sq.mt.)	Deductions (Area in Sq.mt.)	Proposed FAR Area (Sq.mt.)	Total FAR Area (Sq.mt.)	Total Consumed Additional FAR Area (Sq.mt.)	Tnmt (No.)
Ground Floor	85.69	40.18	45.51	45.51	45.51	01
First Floor	97.13	0.00	97.13	97.13	97.13	00
Terrace Floor	0.00	0.00	0.00	0.00	0.00	00
<b>Total :</b>	<b>182.82</b>	<b>40.18</b>	<b>142.64</b>	<b>142.64</b>	<b>142.64</b>	<b>01</b>
Total Number of Same Buildings :	1					
<b>Total :</b>	<b>182.82</b>	<b>40.18</b>	<b>142.64</b>	<b>142.64</b>	<b>142.64</b>	<b>01</b>

Proposal Basic Information

Proposal File No.	AMC/BP/0056/W15/2024
Owner Name	ASHA DEVI AND RUPESH KUMAR
Khata No	59
Plot No	1431
Village Name	DINDLI
Use	Residential
SubUse	Bungalow/ Dwelling / Non Apartment

SCHEDULE OF DOOR:

BUILDING NAME	NAME	LENGTH	HEIGHT	NOS
A (RESIDENTIAL)	D2	0.75	2.10	03
A (RESIDENTIAL)	D2	0.76	2.10	02
A (RESIDENTIAL)	D1	0.90	2.10	03
A (RESIDENTIAL)	D1	0.91	2.10	05
A (RESIDENTIAL)	D	1.22	2.10	01

SCHEDULE OF WINDOW/VENTILATION:

BUILDING NAME	NAME	LENGTH	HEIGHT	NOS
A (RESIDENTIAL)	V	0.60	0.90	03
A (RESIDENTIAL)	W1	1.22	1.20	15
A (RESIDENTIAL)	W	1.80	1.50	01

UnitBUA Table for Building :A (RESIDENTIAL)

FLOOR	Name	UnitBUA Type	UnitBUA Area	Carpet Area	No. of Rooms	No. of Tenement
GROUND FLOOR PLAN	SPLIT A	FLAT	112.79	110.09	4	1
FIRST FLOOR PLAN	SPLIT A	FLAT	0.00	0.00	9	0
<b>Total:</b>	-	-	<b>112.79</b>	<b>110.09</b>	<b>13</b>	<b>1</b>

AREA STATEMENT

ADITYAPUR MUNICIPAL CORPORATION	VERSION NO. : 1.0.73
ADITYAPUR MUNICIPAL CORPORATION	VERSION DATE: 16/10/2020
PROJECT DETAIL:	
Region: JHARKHAND URBAN LOCAL BODIES	Plot Use: Residential
District: EAST SINGBHMUM	Plot SubUse: Bungalow/ Dwelling / Non Apartment
Authority: ADITYAPUR MUNICIPAL CORPORATION	PlotNearby/ReligiousStructure: NA
Inward No: AMC/BP/0056/W15/2024	Plot/ SubPlot No: 1431
Application Type: General Proposal	North: Plot No. - 1431(P)
Project Type: Building Permission	South: Plot No. - 1436
Nature of Development: New	East: Survey No. - nathulal nageliya
Location of Development Area: Old Area	West: Road Width - 6.10
AREA DETAILS:	SQ.MT.
AREA OF PLOT (Minimum)	(A)
NET AREA OF PLOT(Gross Plot Area - Deduction from Gross Plot area)	(A-Deductions)
Deduction for Balance Plot Area(from Gross Plot Area)	
Common Plot	17.06
Total	17.06
BALANCE AREA OF PLOT(Net Plot Area - Recreational/Amenity space)	(A-Deductions)
Plot Area for Coverage(Net Plot Area)	(A-Deductions)
Plot Area for FAR (Net Plot Area + Road Widening Area)	(A-Deductions)
COVERAGRE CHECK	
Permissible Coverage area ( 70.00 % )	99.13
Proposed Coverage Area ( 60.51 % )	85.70
Total Prop. Coverage Area ( 60.51 % )	85.70
Balance coverage area ( 9.48 % )	13.43
FAR CHECK	
Perm. FAR Area ( 2.500 )	354.05
Total Perm. FAR area	354.05
Residential FAR	142.64
Proposed FAR Area	142.64
Total Proposed FAR Area	142.64
Consumed FAR (Factor)	1.01
Balance FAR Area	211.41
BUILT UP AREA CHECK	
Total Proposed BuiltUp Area	182.82
ARCHITECT (Regd)	Abhishek Tewari
ENGINEER (Regd)	
SUPERVISOR (Regd)	
OWNER (Regd)	ASHA DEVI AND RUPESH KUMAR
DEVELOPMENT AUTHORITY	LOCAL BODY

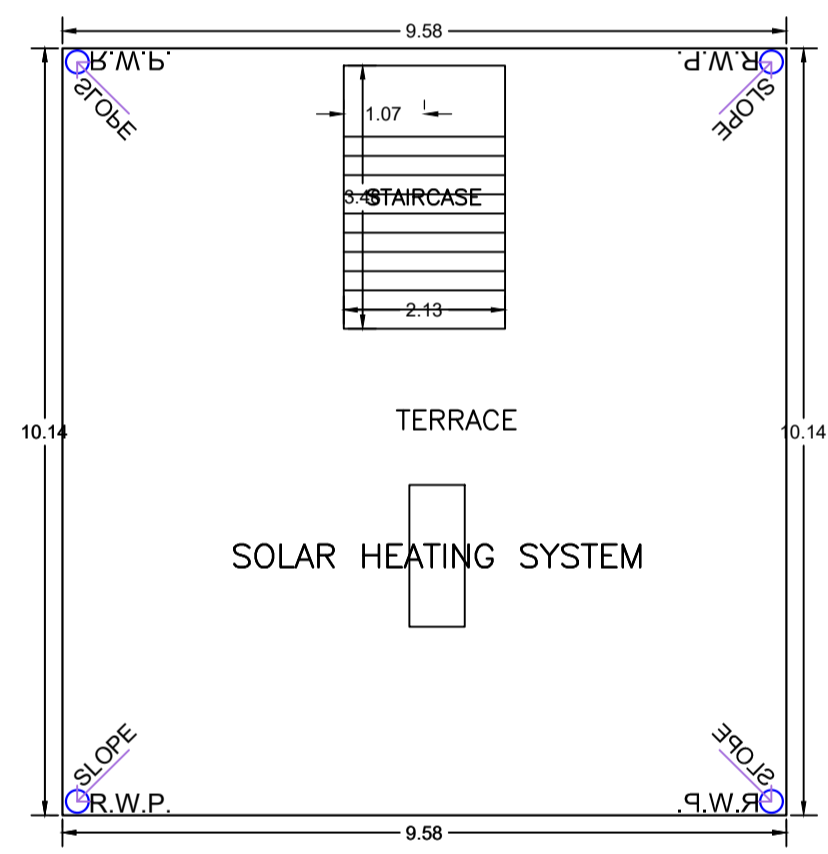
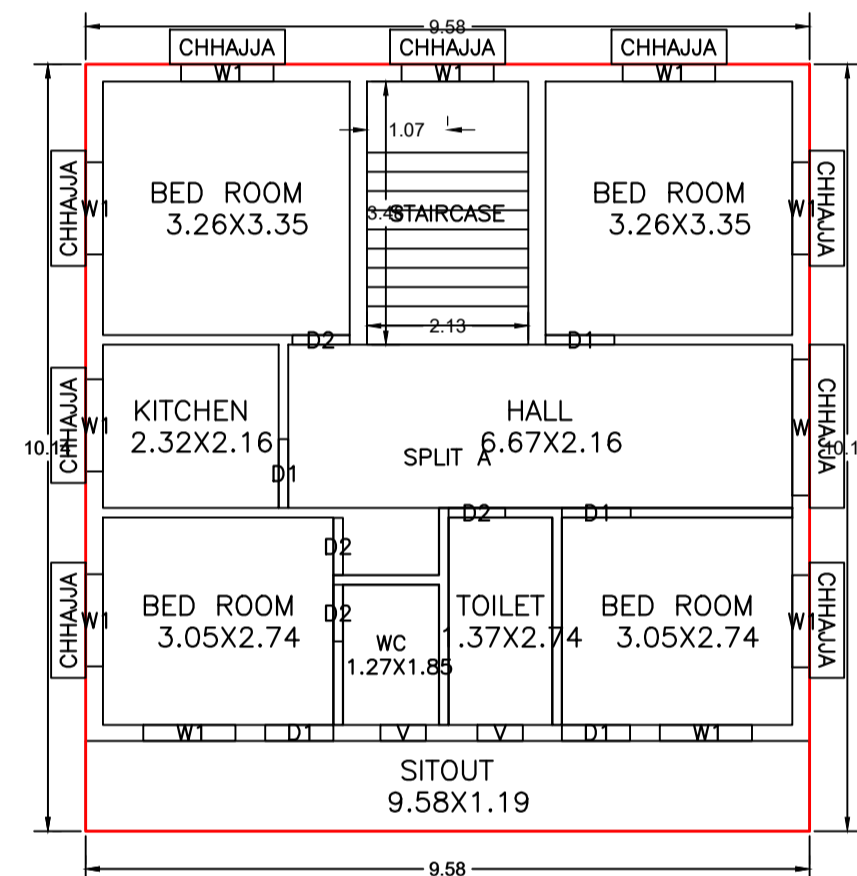
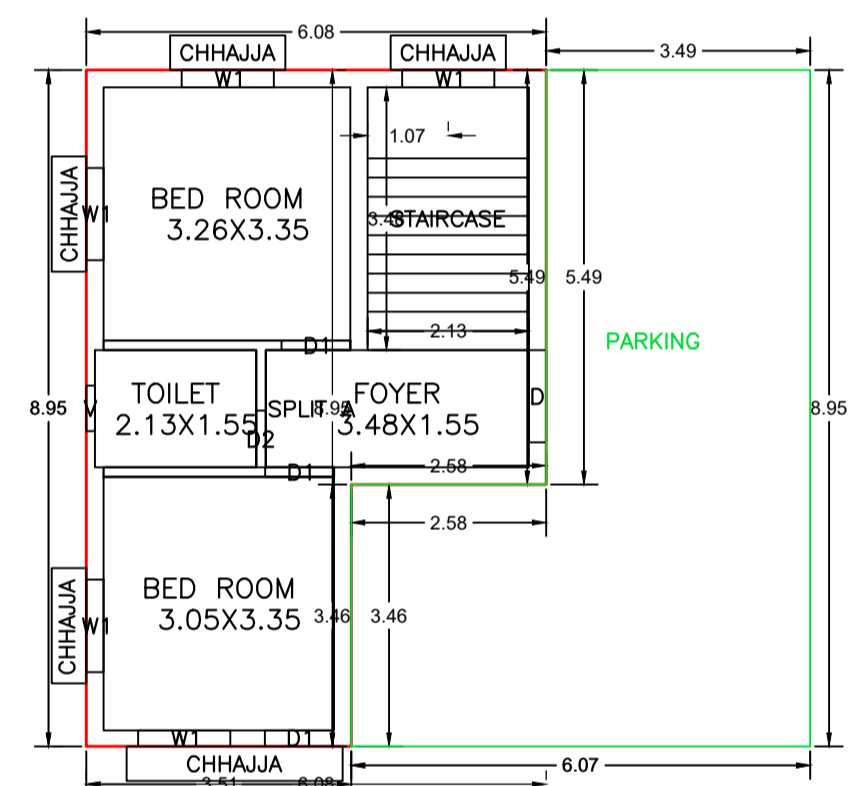

COLOR INDEX

PLOT BOUNDARY	Black
ABUTTING ROAD	Green
PROPOSED CONSTRUCTION	Red
COMMON PLOT	Yellow
ROAD WIDENING AREA	Blue
EXISTING (To be retained)	Orange
EXISTING (To be demolished)	Light Blue

Buildingwise Floor FAR Details

Floor Name	Building Name A (RESIDENTIAL)		Total	
	Proposed Built Up Area (Sq.mt.)	Proposed FAR Area (Sq.mt.)	Total Proposed Built Up Area (Sq.mt.)	Total FAR Area (Sq.mt.)
Ground Floor	85.69	45.51	85.69	45.51
First Floor	97.13	97.13	97.13	97.13
Terrace Floor	0.00	0.00	0.00	0.00
<b>Total :</b>	<b>182.82</b>	<b>142.64</b>	<b>182.82</b>	<b>142.64</b>

Building USE/SUBUSE Details

Building Name	Building Use	Building SubUse	Building Structure	Floor Name	Floor Use	Floor SubUse	FAR Name	FAR Use	FAR SubUse
A (RESIDENTIAL)	Residential	Bungalow/ Dwelling / Non Apartment	Non-Highrise	GROUND FLOOR PLAN	Residential	Bungalow/ Dwelling / Non Apartment	Residential FAR	Residential	Bungalow/ Dwelling / Non Apartment
				FIRST FLOOR PLAN	Residential	Bungalow/ Dwelling / Non Apartment	Residential FAR	Residential	Bungalow/ Dwelling / Non Apartment
				TERRACE FLOOR PLAN	Residential	Bungalow/ Dwelling / Non Apartment	-	-	-

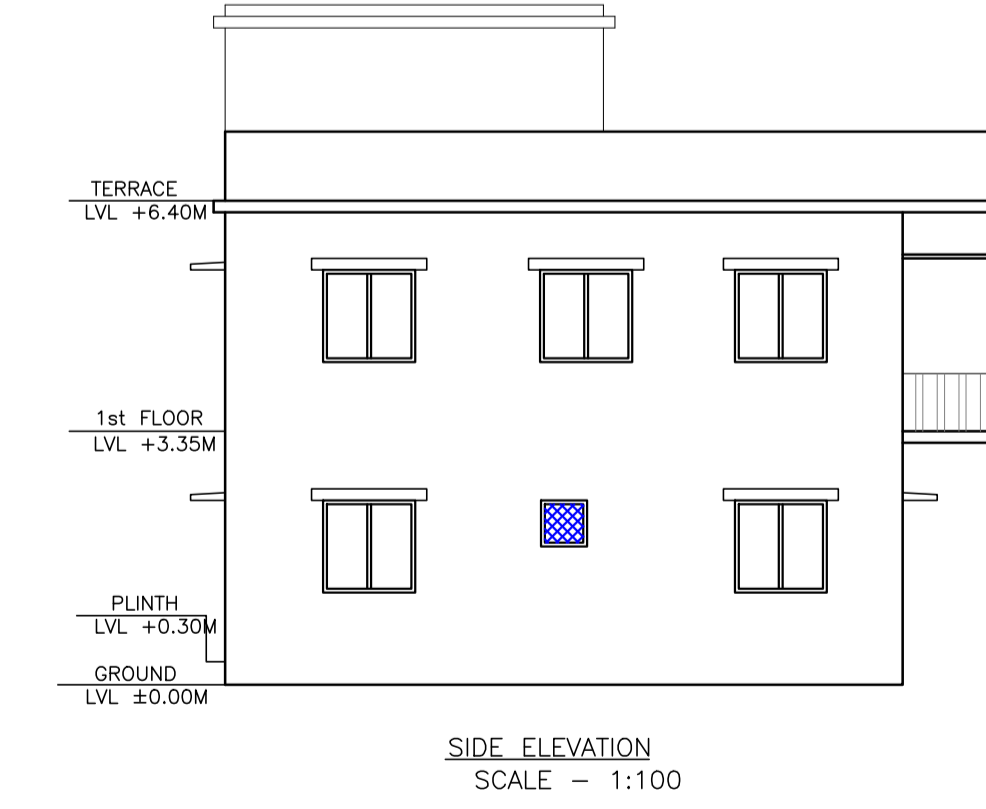
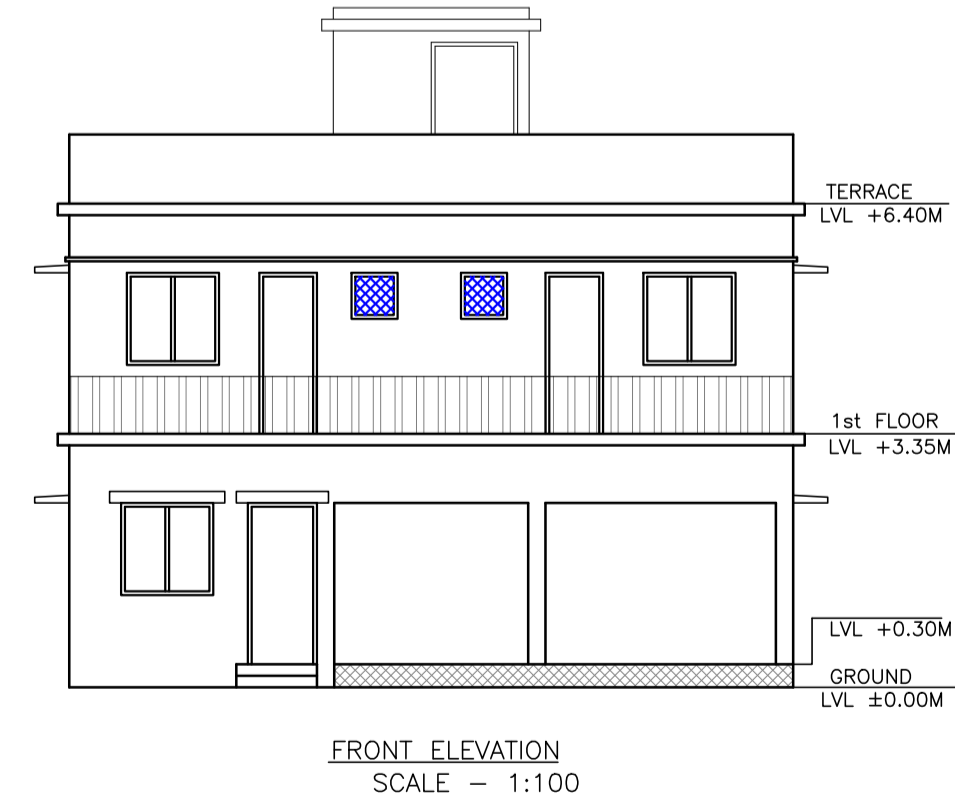
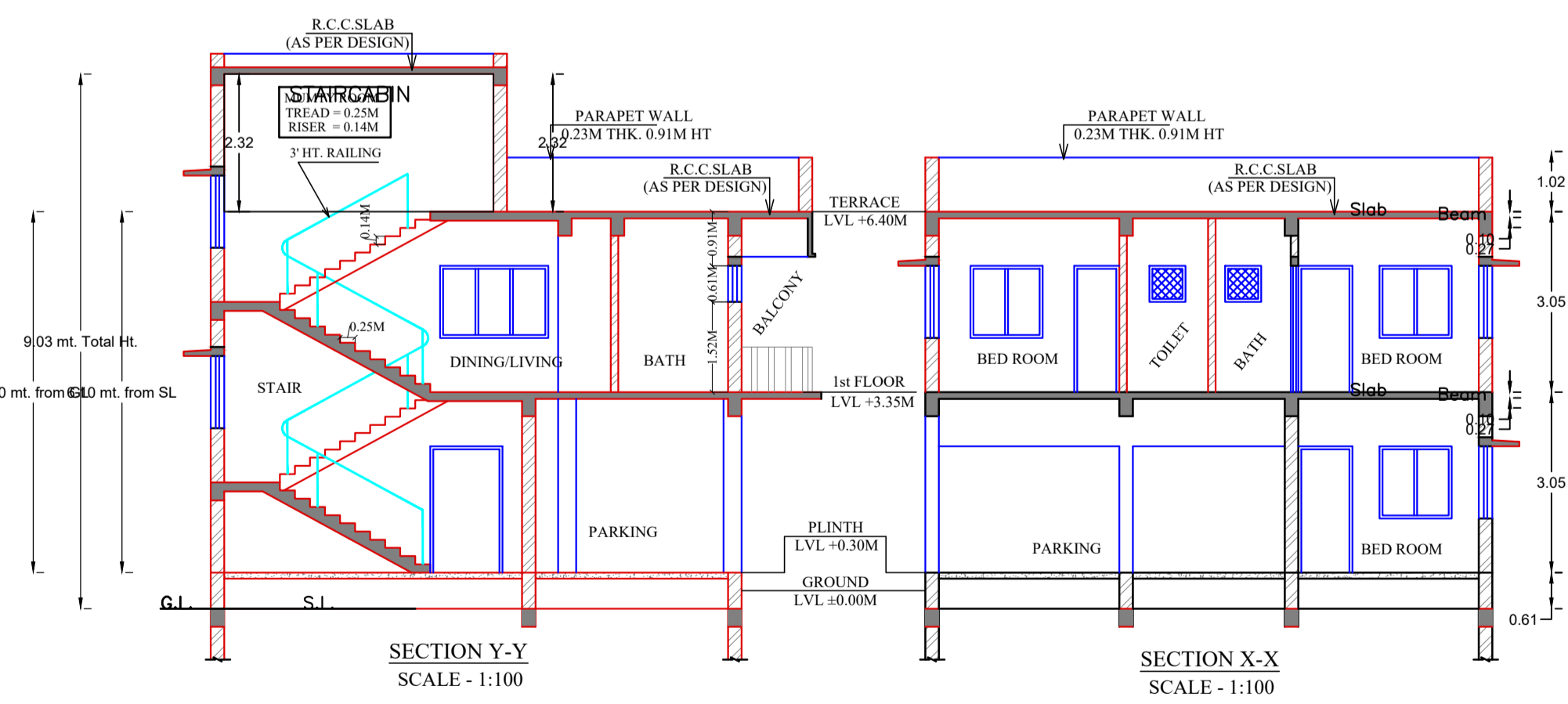

FAR & Tenement Details (Table 4c-1)

Building	No. of Same Bldg	Total Built Up Area (Sq.mt.)	Deductions (Area in Sq.mt.)	Proposed FAR Area (Sq.mt.)	Total FAR Area (Sq.mt.)	Total Consumed Additional FAR Area (Sq.mt.)	Tnmt (No.)
A (RESIDENTIAL)	1	182.82	40.18	142.64	142.64	142.64	01
<b>Grand Total :</b>	<b>1</b>	<b>182.82</b>	<b>40.18</b>	<b>142.64</b>	<b>142.64</b>	<b>142.64</b>	<b>01</b>

LTP NAME AND SIGNATURE	STRUCTURAL ENG'S NAME AND SIGNATURE	BUILDER NAME AND SIGNATURE	DIGITAL SIGNATURE
Abhishek Tewari AMC/ARC/0026/2016			

Proposal Basic Information	
Proposal File No.	AMC/BP/0056/W15/2024
Owner Name	ASHA DEVI AND RUPESH KUMAR
Khata No	59
Plot No	1431
Village Name	DINDLI
Use	Residential
SubUse	Bungalow/ Dwelling / Non Apartment

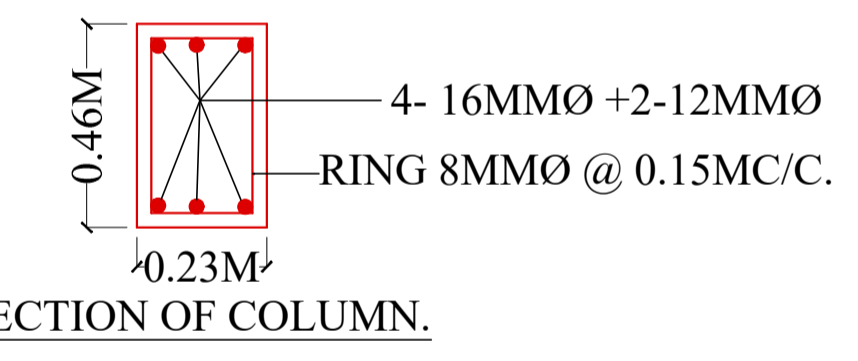
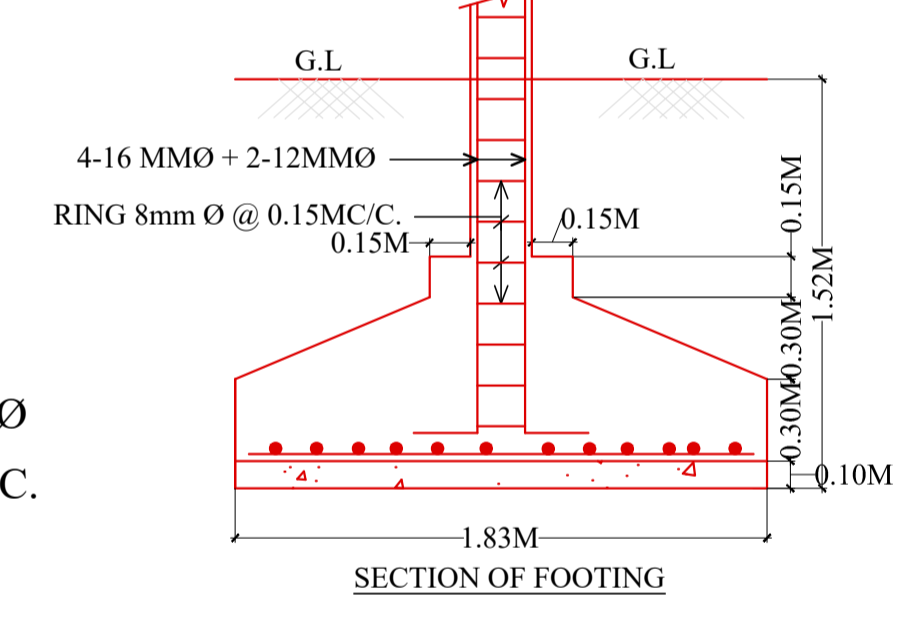
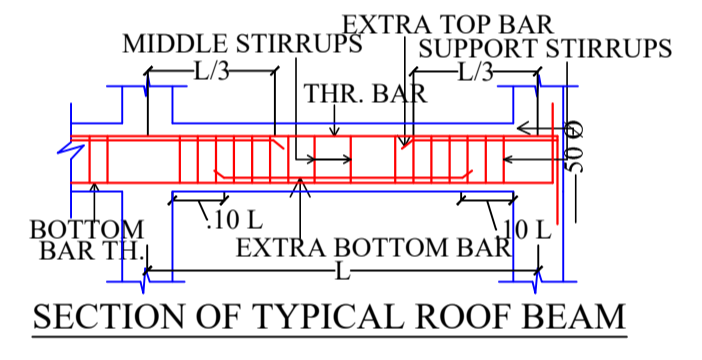
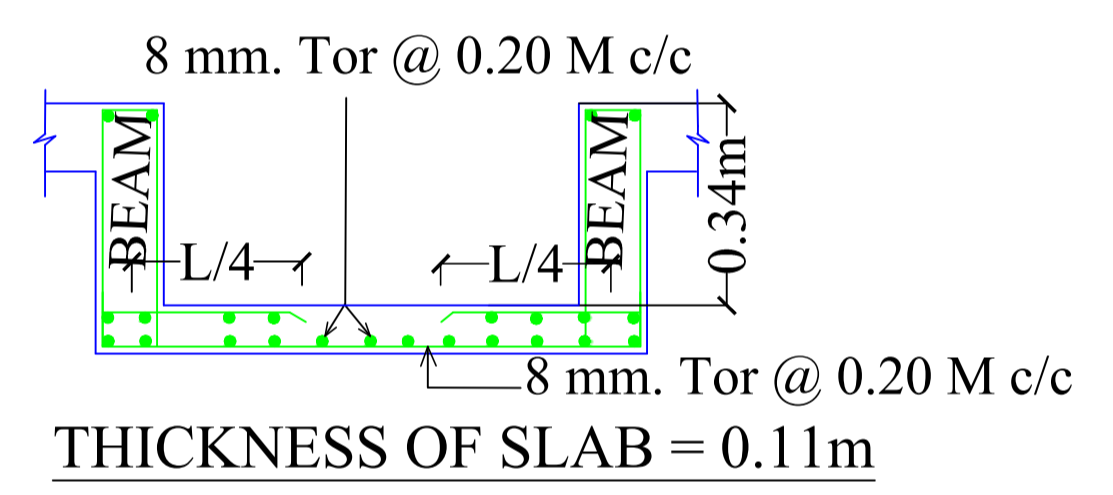
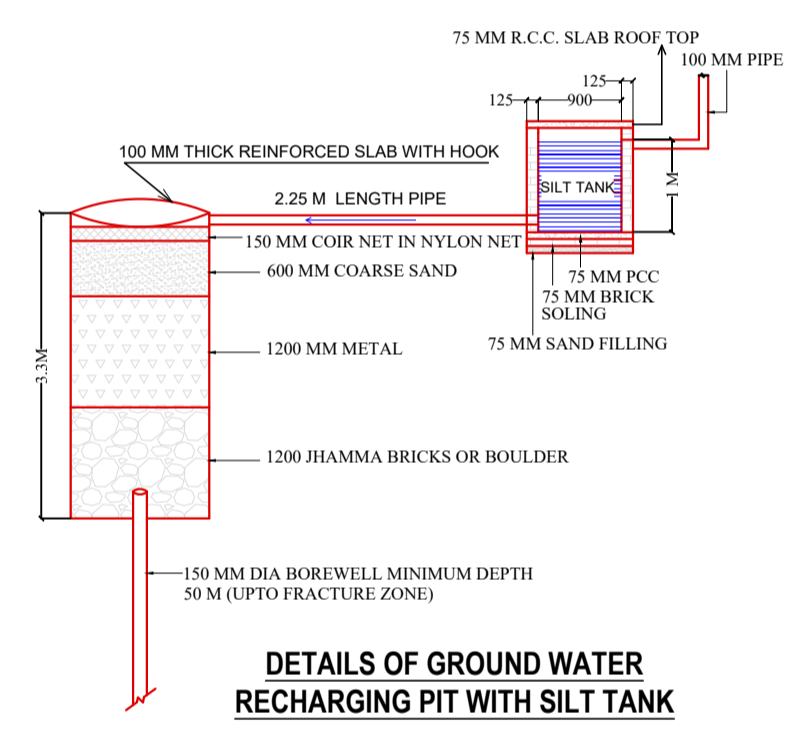
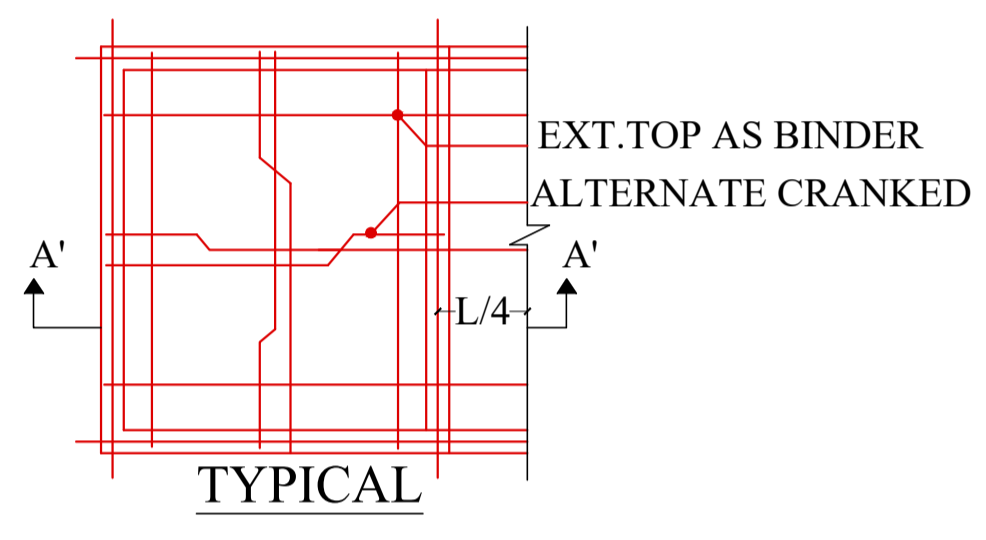
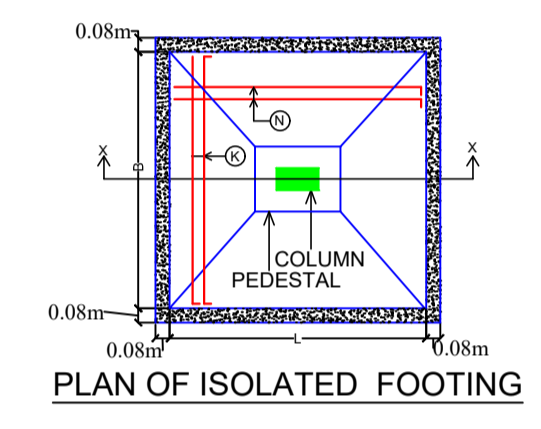
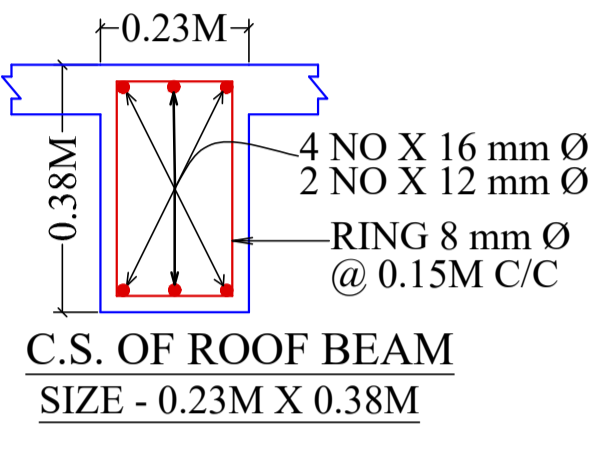
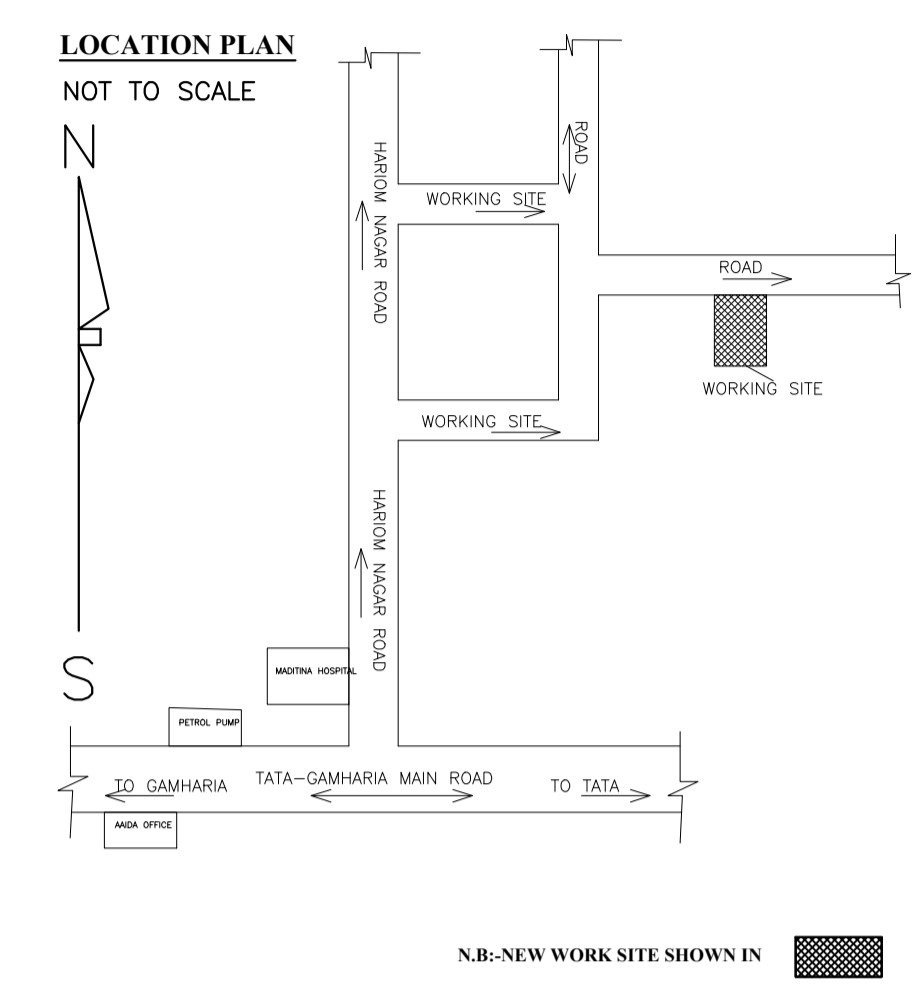
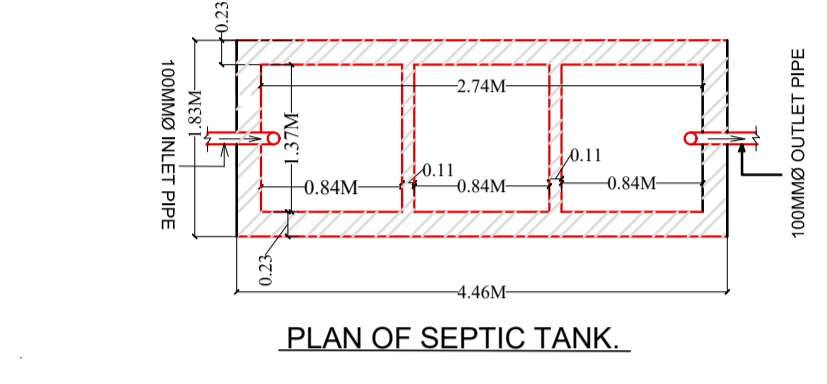
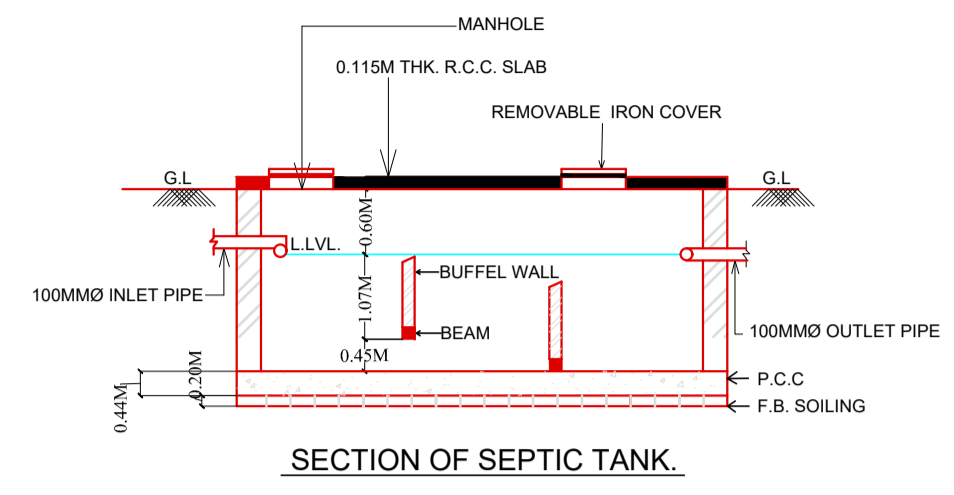
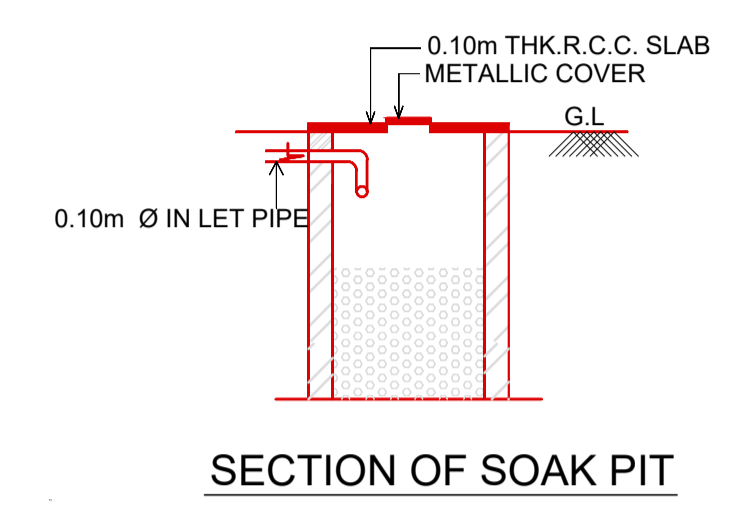
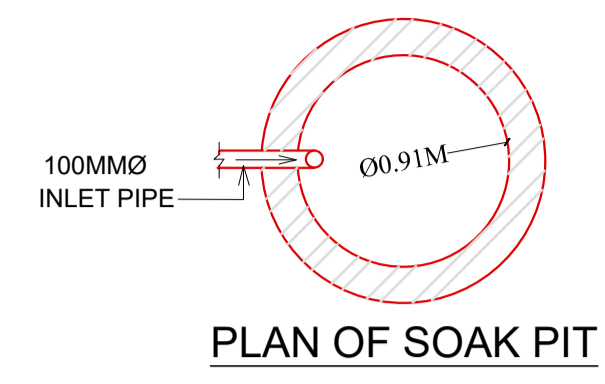
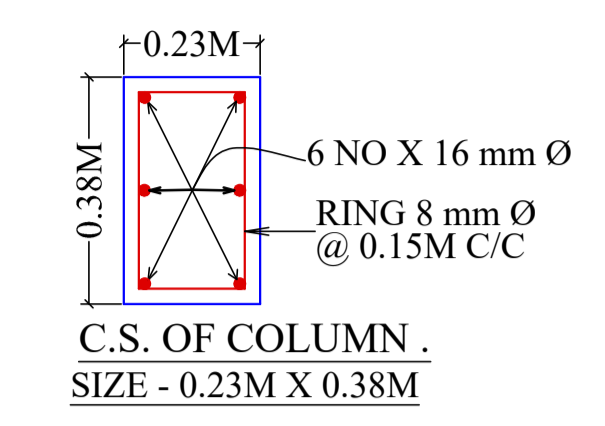

LTP NAME AND SIGNATURE	STRUCTURAL ENG'S NAME AND SIGNATURE	BUILDER NAME AND SIGNATURE	DIGITAL SIGNATURE
Abhishek Tewari AMC/ARC/0026/2016			