

UnitBUA Table for Building :A (PRO)

FLOOR	Name	UnitBUA Type	UnitBUA Area	Carpet Area	No. of Rooms	No. of Tenement
GROUND FLOOR PLAN	SPLIT 1	FLAT	85.87	73.70	7	1
Total:	-	-	85.87	73.70	7	1

Building USE/SUBUSE Details

Building Name	Building Use	Building SubUse	Building Structure
A (PRO)	Residential	Bungalow/ Dwelling / Non Apartment	Non-Highrise

COLOR INDEX

PLOT BOUNDARY	Black
ABUTTING ROAD	Green
PROPOSED CONSTRUCTION	Red
COMMON PLOT	Yellow
ROAD WIDENING AREA	Blue
EXISTING (To be retained)	Light Blue
EXISTING (To be demolished)	Dark Blue

AREA STATEMENT CHAS MUNICIPAL CORPORATION	VERSION NO.: 1.0.21	SQ.MT.
PROJECT DETAIL:	REGION: JHARKHAND URBAN LOCAL BODIES	283.22
Plot Use: Residential	Plot SubUse: Bungalow/ Dwelling / Non Apartment	
Authority: CHAS MUNICIPAL CORPORATION	PlotNearby/ReligiousStructure: NA	
Inward No: CMC/EP/0043/W31/2018	Plot/SubPlot No: 28	
Application Type: General Proposal	North: Road Width - 50 m road	
Project Type: Building Permission	South: CTS No. - nij	
Nature of Development: New	East: CTS No. - nij	
Location of Development Area: New Area	West: CTS No. - banshidhar mahatha	
AREA OF PLOT (Minimum)	(A)	283.22
NET AREA OF PLOT (Gross Plot Area - Deduction from Gross Plot area)	(A-Deductions)	283.22
Deduction for Balance Plot Area (from Gross Plot Area)		
Common Plot		17.02
Total		17.02
BALANCE AREA OF PLOT (Net Plot Area - Recreational/Amenity space)	(A-Deductions)	266.20
PLOT AREA FOR COVERAGE (Net Plot Area)	(A-Deductions)	283.22
Plot Area for FAR (Net Plot Area + Road Widening Area)	(A-Deductions)	283.22
COVERAGE CHECK		
Permissible Coverage area ( 60.00 % )		169.93
Proposed Coverage Area ( 30.32 % )		85.87
Total Prop. Coverage Area ( 30.32 % )		85.87
Balance coverage area ( 29.68 % )		84.06
FAR CHECK		
Perm. FAR Area ( 2.50 )		708.05
Total Perm. FAR area		708.05
Residential FAR		85.87
Proposed FAR Area		85.87
Total Proposed FAR Area		85.87
Consumed FAR (Factor)		0.30
Balance FAR Area		622.18
BUILT UP AREA CHECK		
Total Proposed BuiltUp Area		85.87
ARCHITECT (Regd)	Suresh Prasad Singh	
ENGINEER (Regd)		
SUPERVISOR (Regd)		
OWNER (Regd)	RENU DEVI	
DEVELOPMENT AUTHORITY	LOCAL BODY	

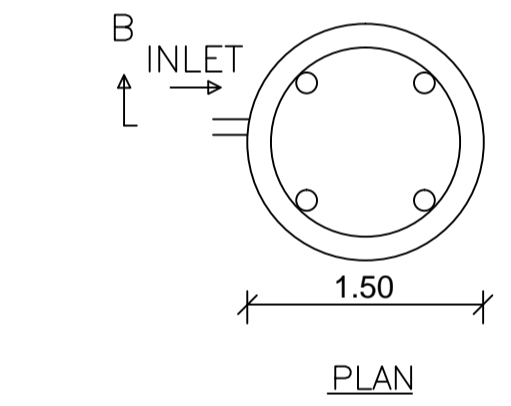
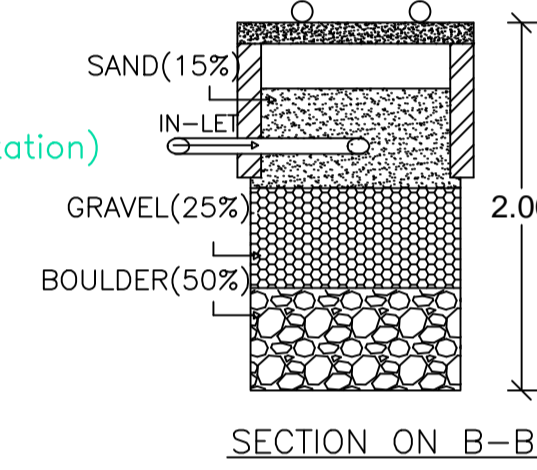
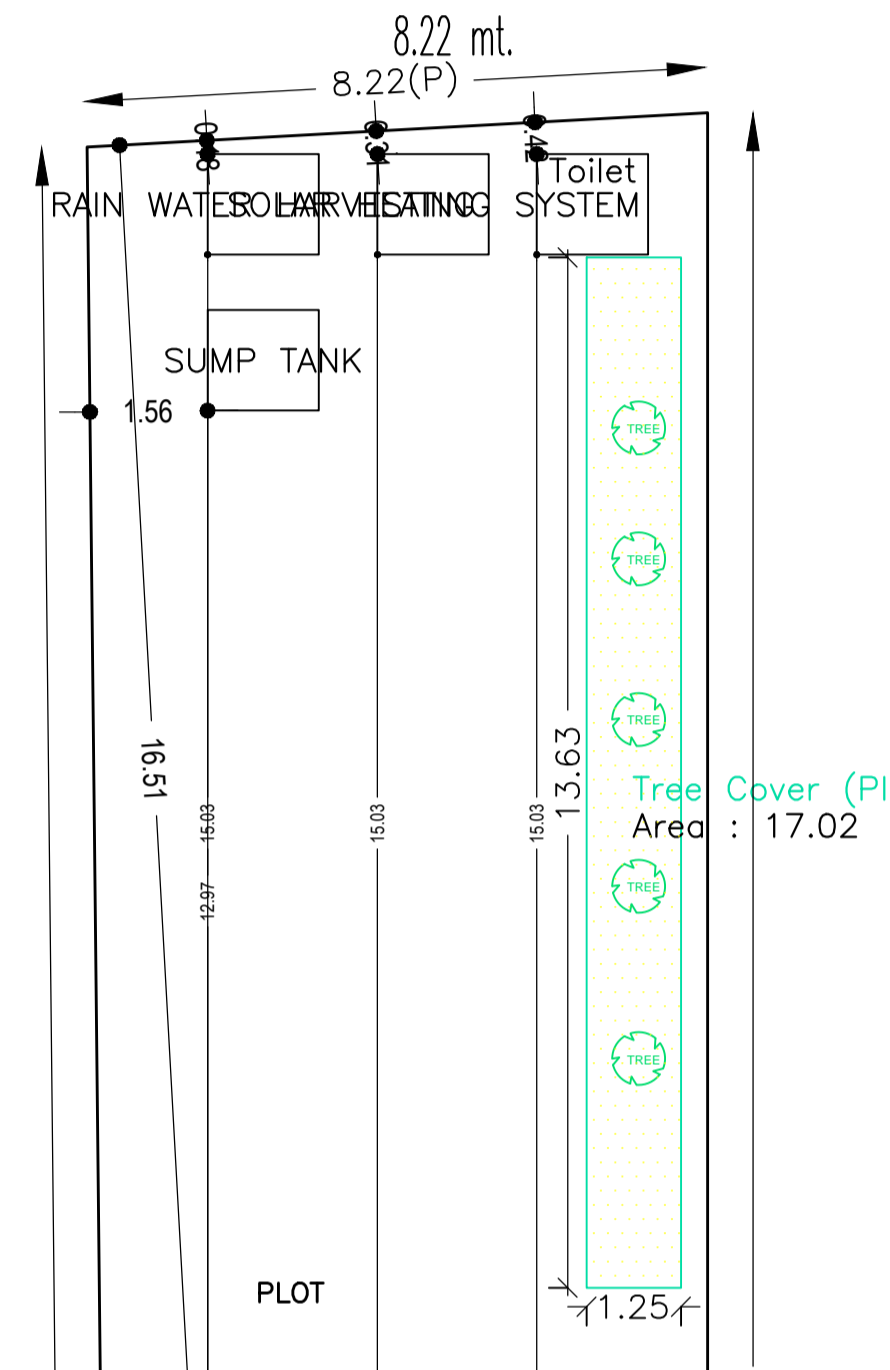
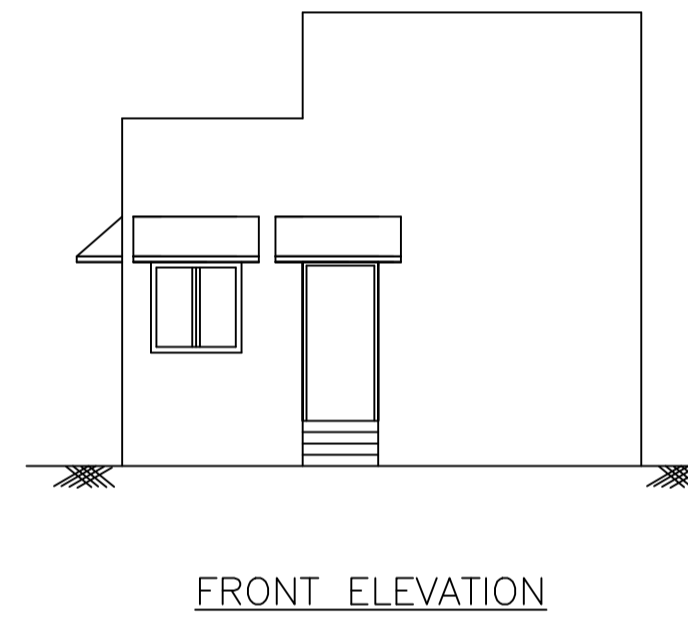
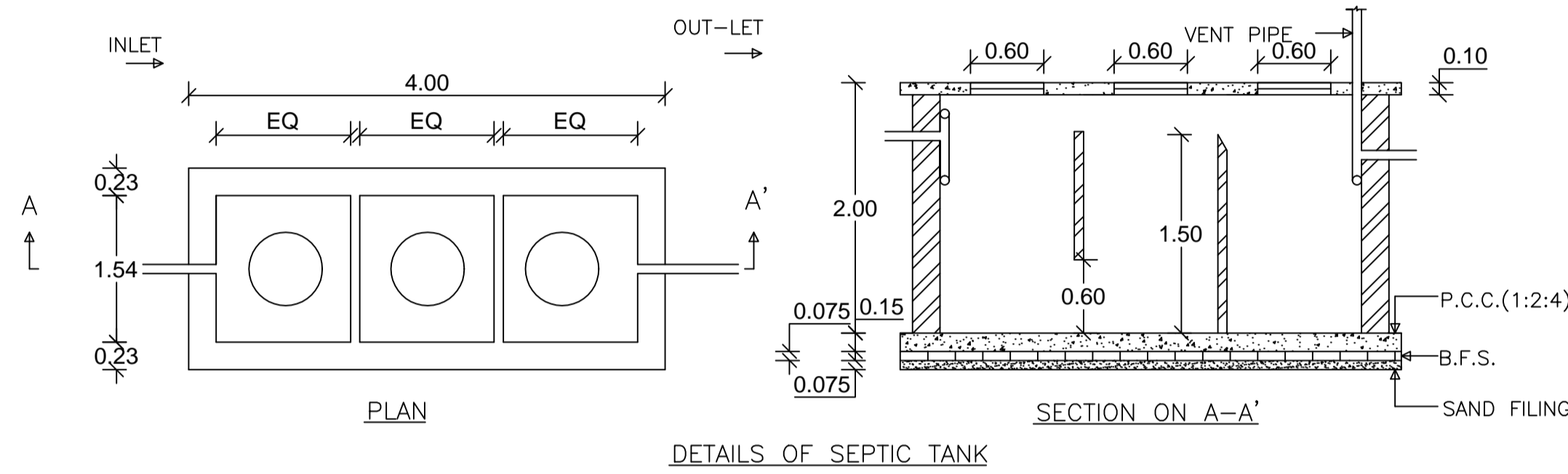

DETAILS OF WATER HARVESTING

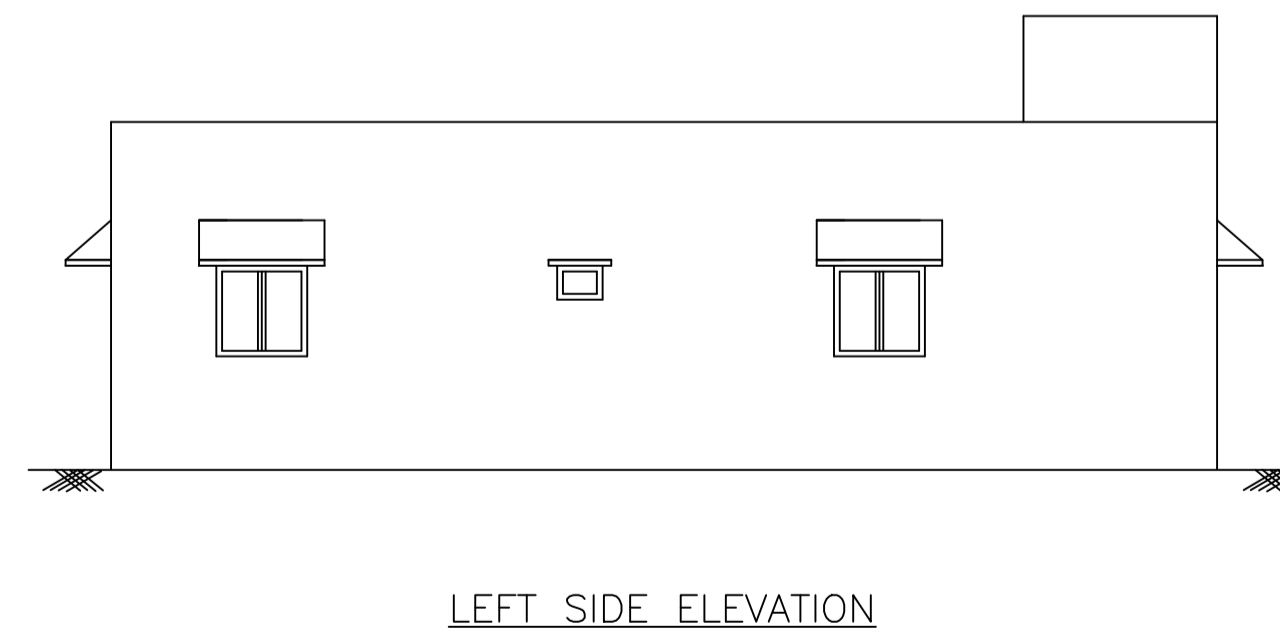
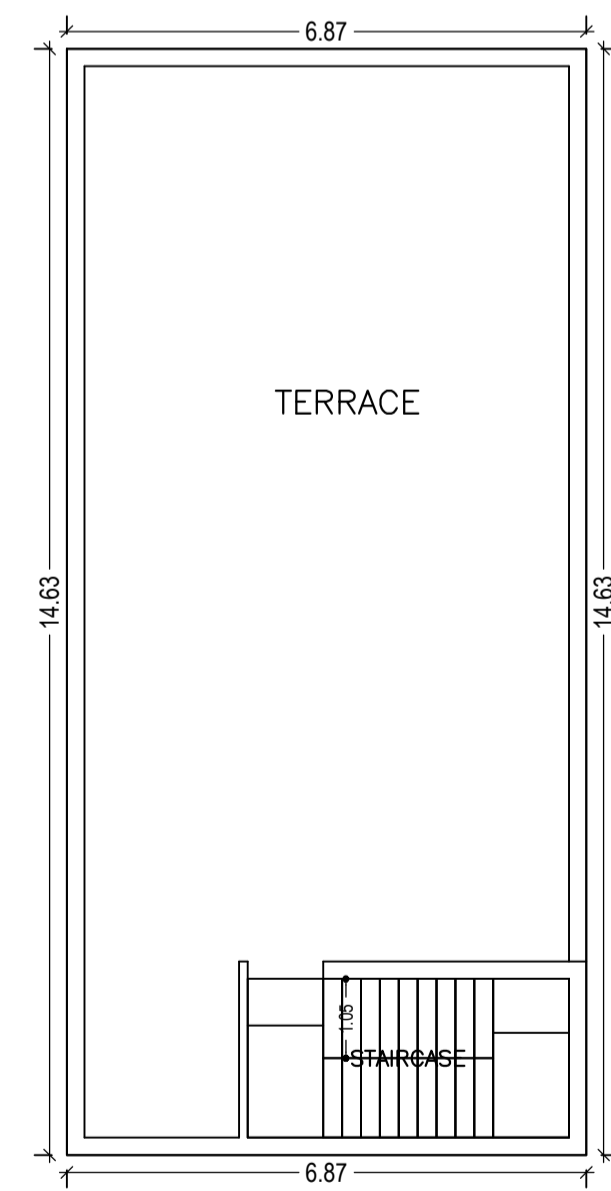
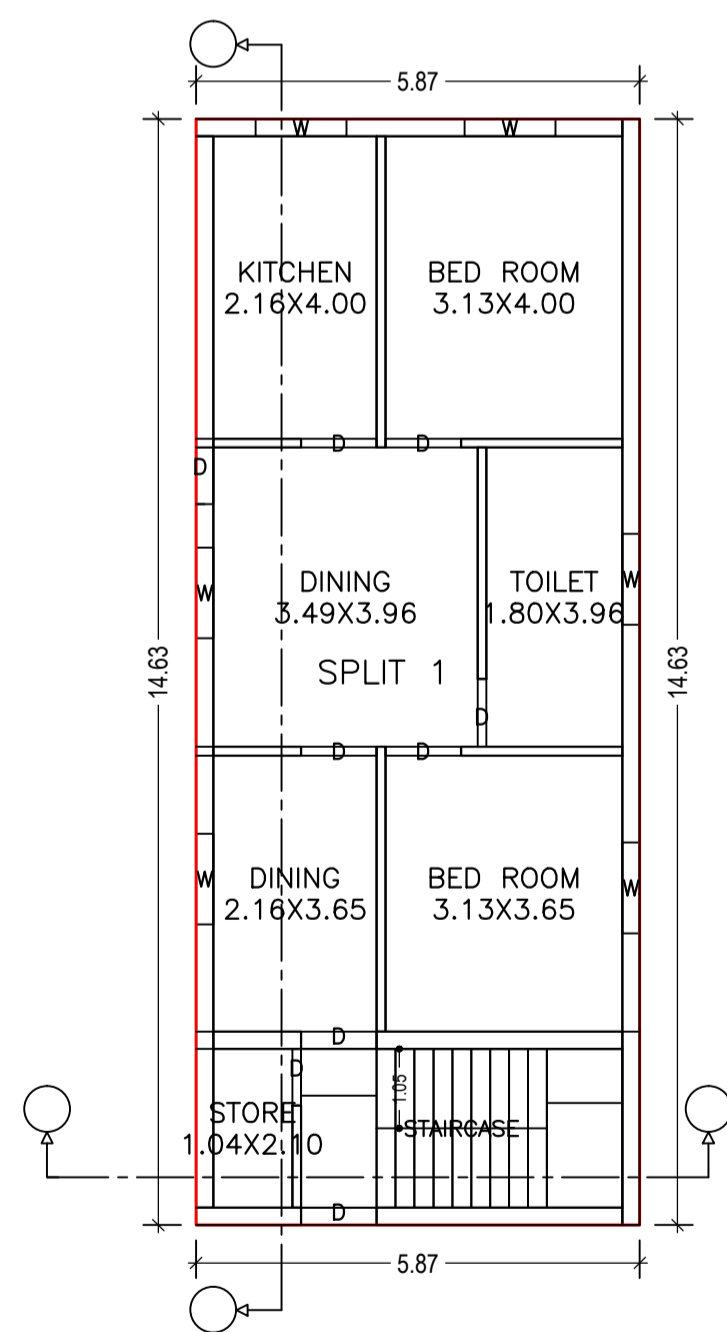

A (PRO)  
BLDG HT: 3.00 MT.  
NO. OF FLOORS: 1

SITE PLAN

Building :A (PRO)

Floor Name	Total Built Up Area (Sq.mt.)	Proposed FAR Area (Sq.mt.) Resi.	Total FAR Area (Sq.mt.)	Total Consumed Additional FAR Area (Sq.mt.)	Tnmt (No.)
Ground Floor	85.87	85.87	85.87	85.87	01
Terrace Floor	0.00	0.00	0.00	0.00	00
Total :	85.87	85.87	85.87	85.87	01
Total Number of Same Buildings :	1				
Total :	85.87	85.87	85.87	85.87	01

Buildingwise Floor FAR Details

Floor Name	Building Name A (PRO)		Total	
	Proposed Built Up Area (Sq.mt.)	Proposed FAR Area (Sq.mt.)	Total Proposed Built Up Area (Sq.mt.)	Total FAR Area (Sq.mt.)
Ground Floor	85.87	85.87	85.87	85.87
Terrace Floor	0.00	0.00	0.00	0.00
Total :	85.87	85.87	85.87	85.87

FAR & Tenement Details (Table 4c-1)

Building	No. of Same Bldg	Total Built Up Area (Sq.mt.)	Proposed FAR Area (Sq.mt.) Resi.	Total FAR Area (Sq.mt.)	Total Consumed Additional FAR Area (Sq.mt.)	Tnmt (No.)
A (PRO)	1	85.87	85.87	85.87	85.87	01
Grand Total :	1	85.87	85.87	85.87	85.87	01

SCHEDULE OF DOOR:

BUILDING NAME	NAME	LENGTH	HEIGHT	NOS
A (PRO)	D	0.75	2.10	02
A (PRO)	D	0.90	2.10	01
A (PRO)	D	1.00	2.10	05

SCHEDULE OF WINDOW/VENTILATION:

BUILDING NAME	NAME	LENGTH	HEIGHT	NOS
A (PRO)	W	1.20	1.20	06

LTP NAME AND SIGNATURE	STRUCTURAL ENG'S NAME AND SIGNATURE	BUILDER NAME AND SIGNATURE
Suresh Prasad Singh CMC/ENG/0002/2017		