

Project Title: SMT BIJAYA JHA

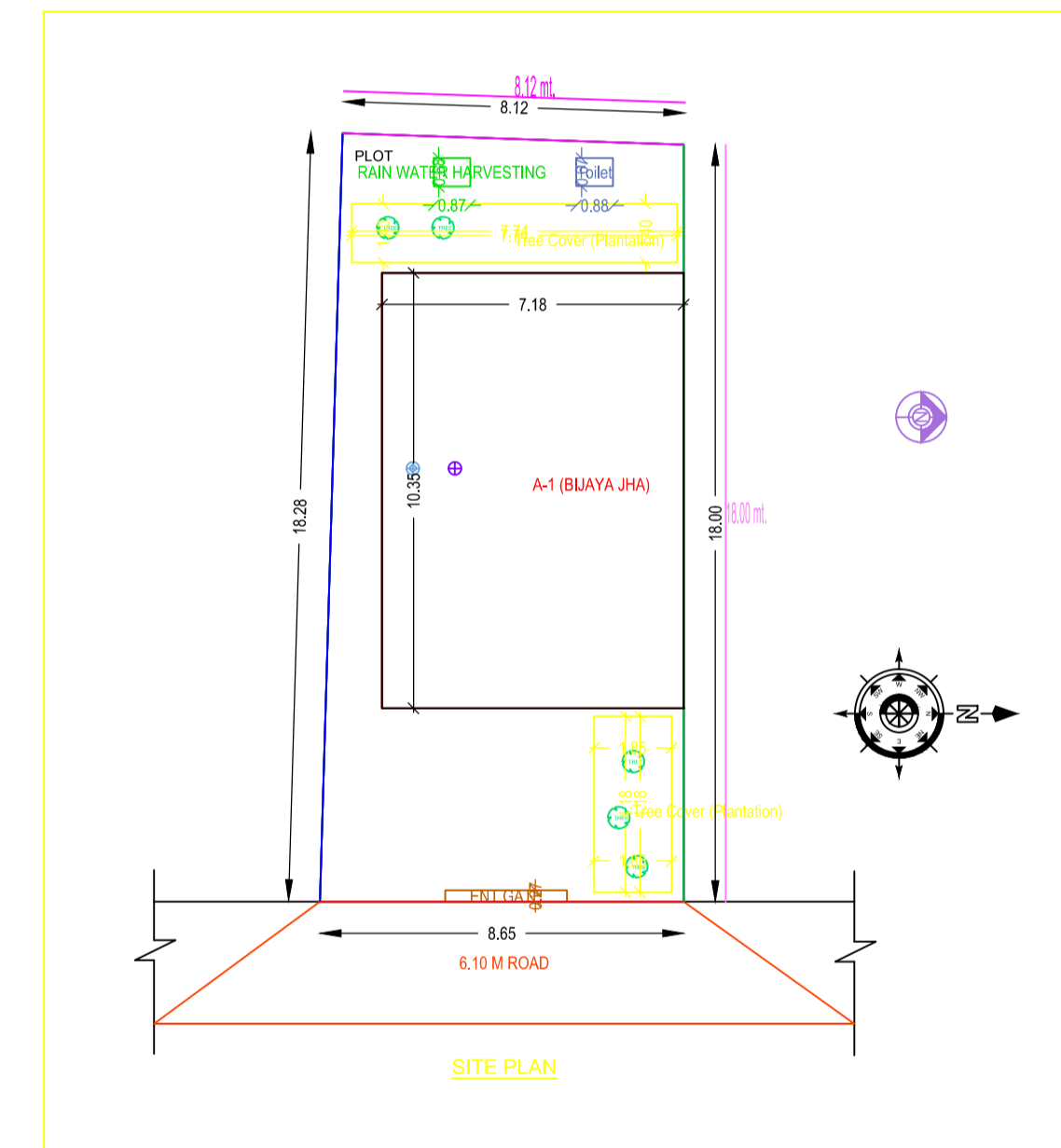
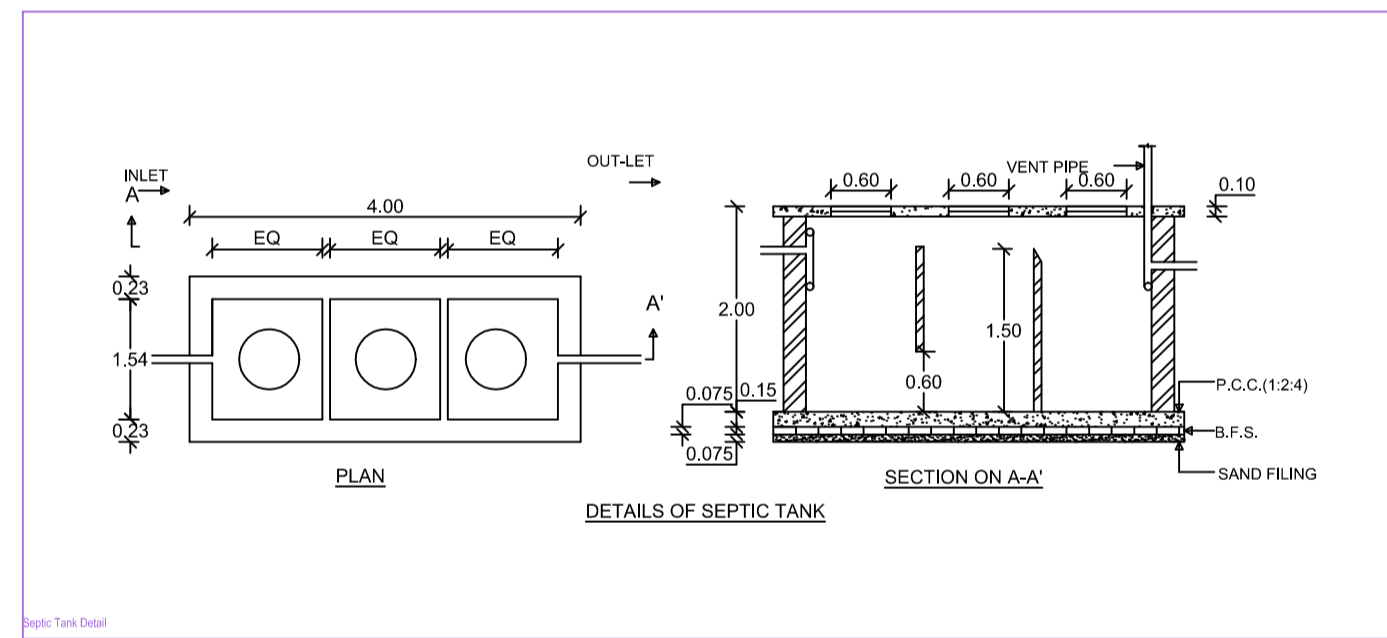
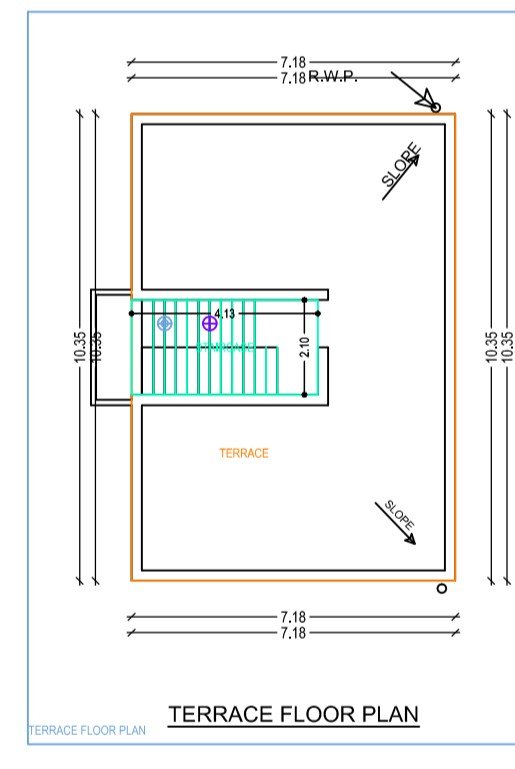
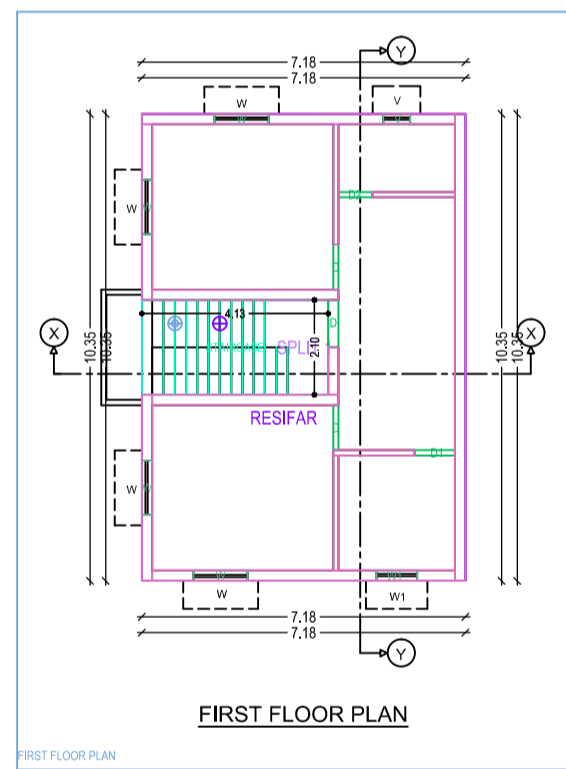
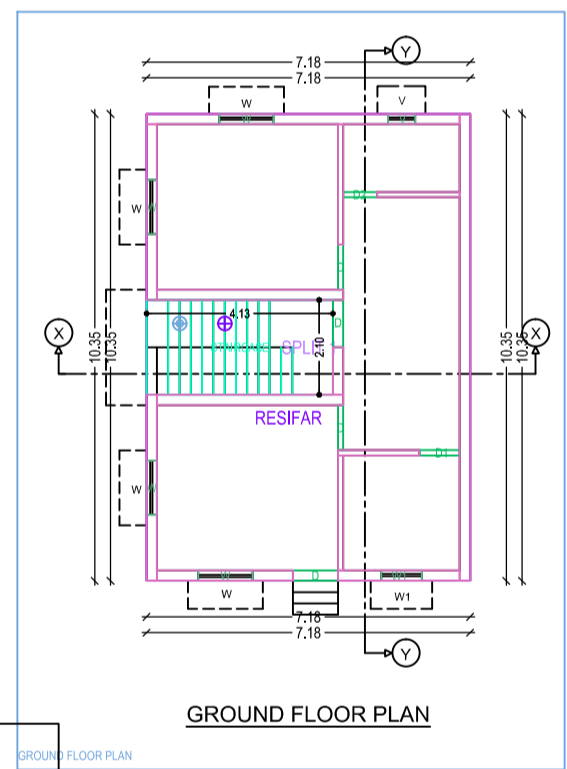
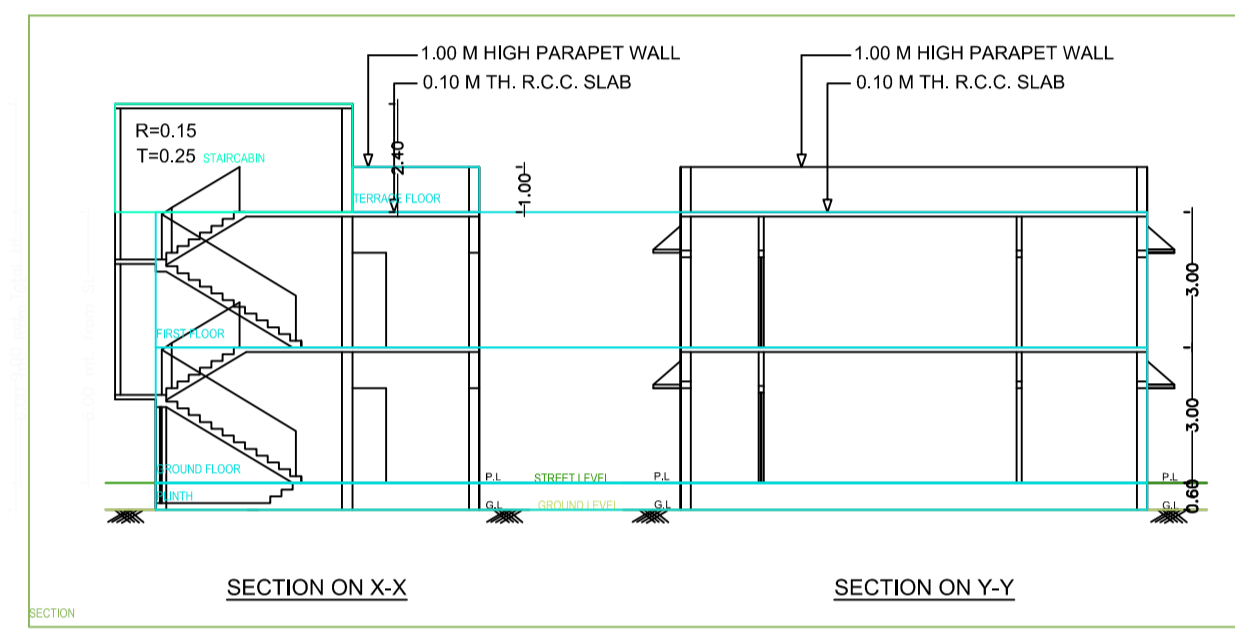
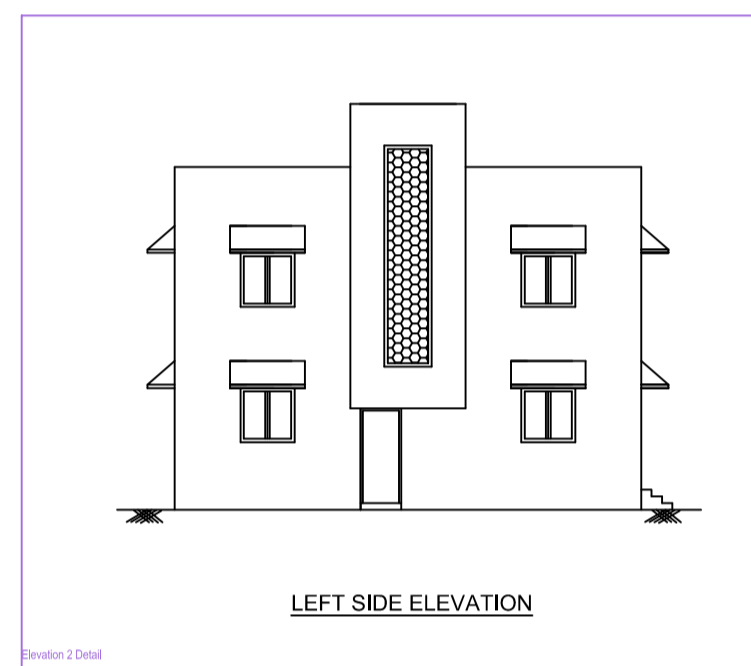
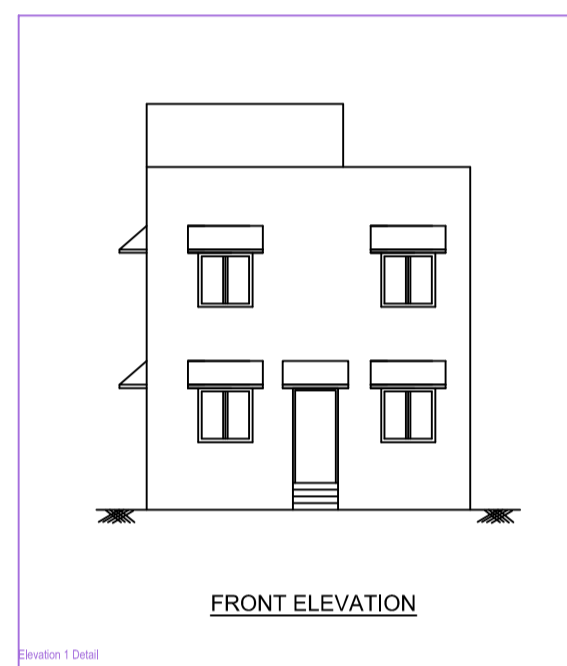
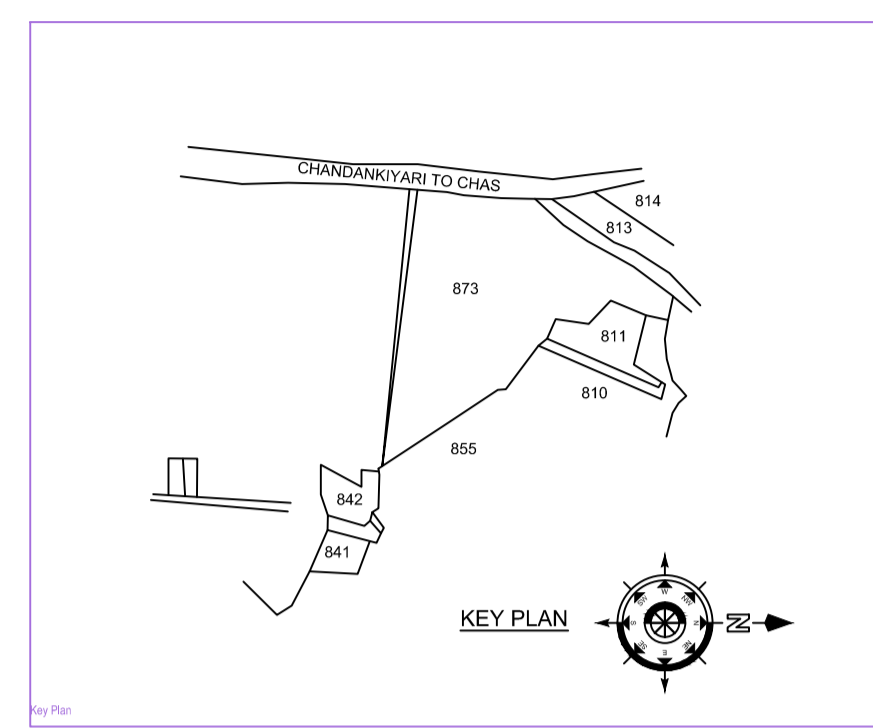
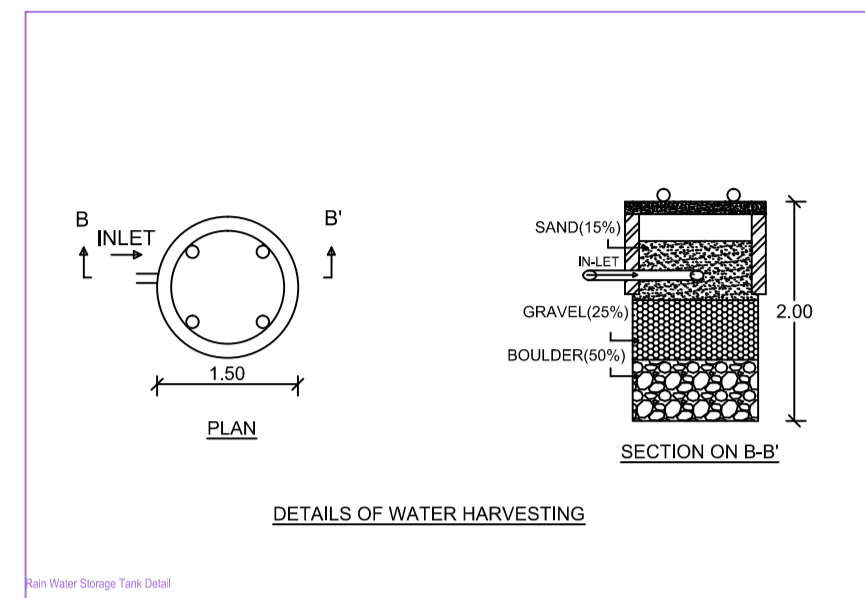
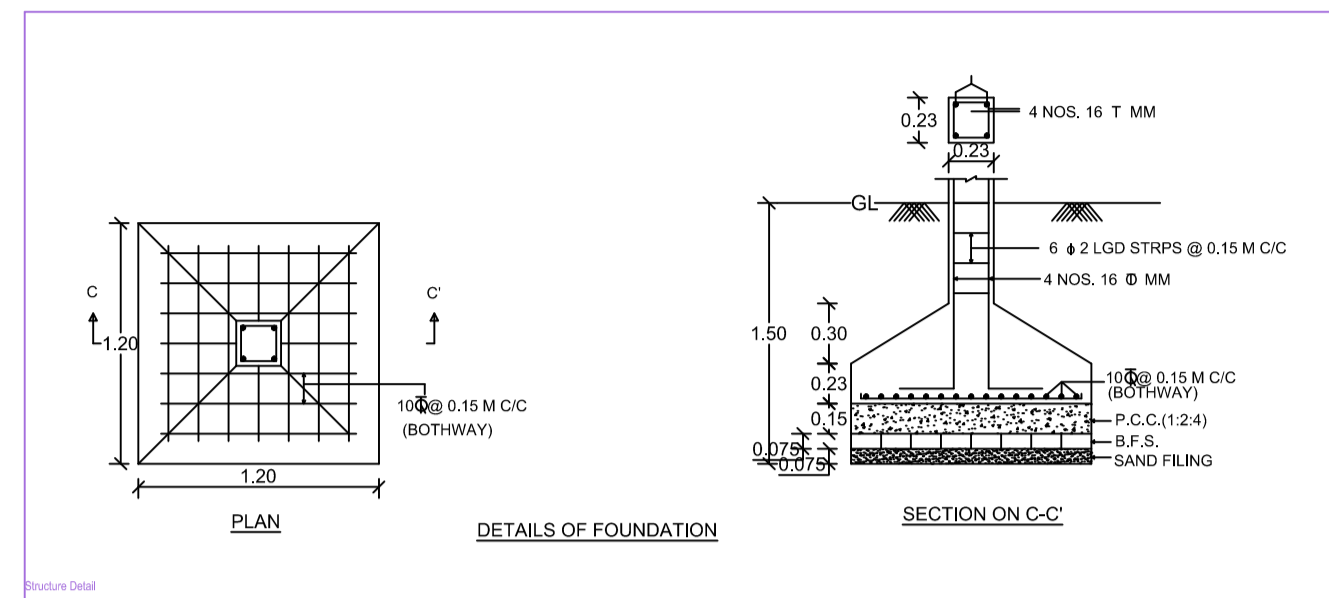

AREA STATEMENT: CHAS MUNICIPAL CORPORATION		VERSION NO. 1.0.15
PROJECT DETAILS:		VERSION DATE: 30/06/2018
Project No.:	Plot Use: Residential	
Region: CHANDANKHIAN LOCAL BODY	Plot Location: Bungalow Dwelling / Not Apartment	
Project Name: Building Permission	Land Use Zone: R2	
Application Type: General Proposal	Abutting Road Width: -	
Project Type: Building Permission	Plot No.:	
Number of Development: Area	Plot No.:	
Location: 04 Area	Thana No.:	
Site Location: RA	Block No.:	
Village/Moza Name: -	Khata No.:	
Plot No.:	Block:	
Block/Street: -	Plot:	
AREA DETAILS:		Plot Area: 152.07
Area of Plot (Sqm):	Area (A):	152.07
Net Plot Area (Green Plot Area):	(A-Deductions):	152.07
- Deduction from Green Plot Area:		152.07
- Deduction from Green Plot Area:		152.07
COF Area:		152.07
Net Plot Area (Net Plot Area):	(A-Deductions):	152.07
- Deduction from Green Plot Area:		152.07
Plot Area for Coverage (Net Plot Area):	(A-Deductions):	152.07
- Deduction from Green Plot Area:		152.07
Plot Area for FSI (Net Plot Area):	(A-Deductions):	152.07
- Deduction from Green Plot Area:		152.07
Accessory Plot Area:		0.00
COVERAGE CHECK:		
Proposed Coverage Area (48.83 %):		74.26
Total Coverage Area (48.83 %):		74.26
FAR CHECK:		
Proposed Area of FAR:		148.52
Net Area of FAR:		148.52
BUILDING TYPE CHECK:		
Net Proposed Build Up Area:		148.52
APPROVED/ENDORSEMENT/REMARK (If any):		OWNER
DEVELOPMENT AUTHORITY:		LOCAL BODY

COLOR INDEX	
Plot Boundary	Red
Plot Boundary	Green
Proposed Work (Coverage Area)	Blue
Existing (To be retained)	Yellow
Existing (To be demolished)	Black

MARGIN DETAIL:					
Building / Wing	Road Name	Front Margin	Rear Margin	Side Margin	Side Margin
A-1 (BIJAYA JHA)	2.10 M ROAD	4.50	3.05	1.04	0.00

FAR & Terment Details (Table 4-1)					
Building	No. of Same Bldg	Total Built Up Area (Sq.M)	Proposed FAR Area (Sq.M)	Total FAR Area (Sq.M)	Term (No.)
A-1 (BIJAYA JHA)	1	148.52	148.52	148.52	01
Grand Total	1	148.52	148.52	148.52	01

Building -A (BIJAYA JHA)

Floor Name	Total Built Up Area (Sq.M)	Proposed FAR Area (Sq.M)	Total FAR Area (Sq.M)	Term (No.)
Ground Floor	74.26	74.26	74.26	01
First Floor	74.26	74.26	74.26	02
Terrace Floor	0.00	0.00	0.00	00
Total	148.52	148.52	148.52	01
Total Number of Same Buildings	1			
Total	148.52	148.52	148.52	01

SCHEDULE OF JOINERY:

BUILDING NAME	NAME	LENGTH	HEIGHT	NO.
A-1 (BIJAYA JHA)	D1	0.75	2.10	02
A-1 (BIJAYA JHA)	D1	0.90	2.10	02
A-1 (BIJAYA JHA)	D	1.00	2.10	02
A-1 (BIJAYA JHA)	D	1.00	2.10	02
Total	-	-	-	11

SCHEDULE OF JOINERY:

BUILDING NAME	NAME	LENGTH	HEIGHT	NO.
A-1 (BIJAYA JHA)	W	0.90	1.00	02
A-1 (BIJAYA JHA)	W1	0.90	1.20	02
A-1 (BIJAYA JHA)	W	1.20	1.20	02
Total	-	-	-	12

UnitBUA Table for Building -A (BIJAYA JHA)

FLOOR	Name	UnitBUA Type	UnitBUA Area	Carpet Area	No. of Rooms	No. of Tenement
GROUND FLOOR	SPLIT 1	FLAT	148.52	127.70	5	1
Total	-	-	148.52	127.70	10	1

K (BIJAYA JHA)