

Project Title :DEEPAK KUMAR JALAN

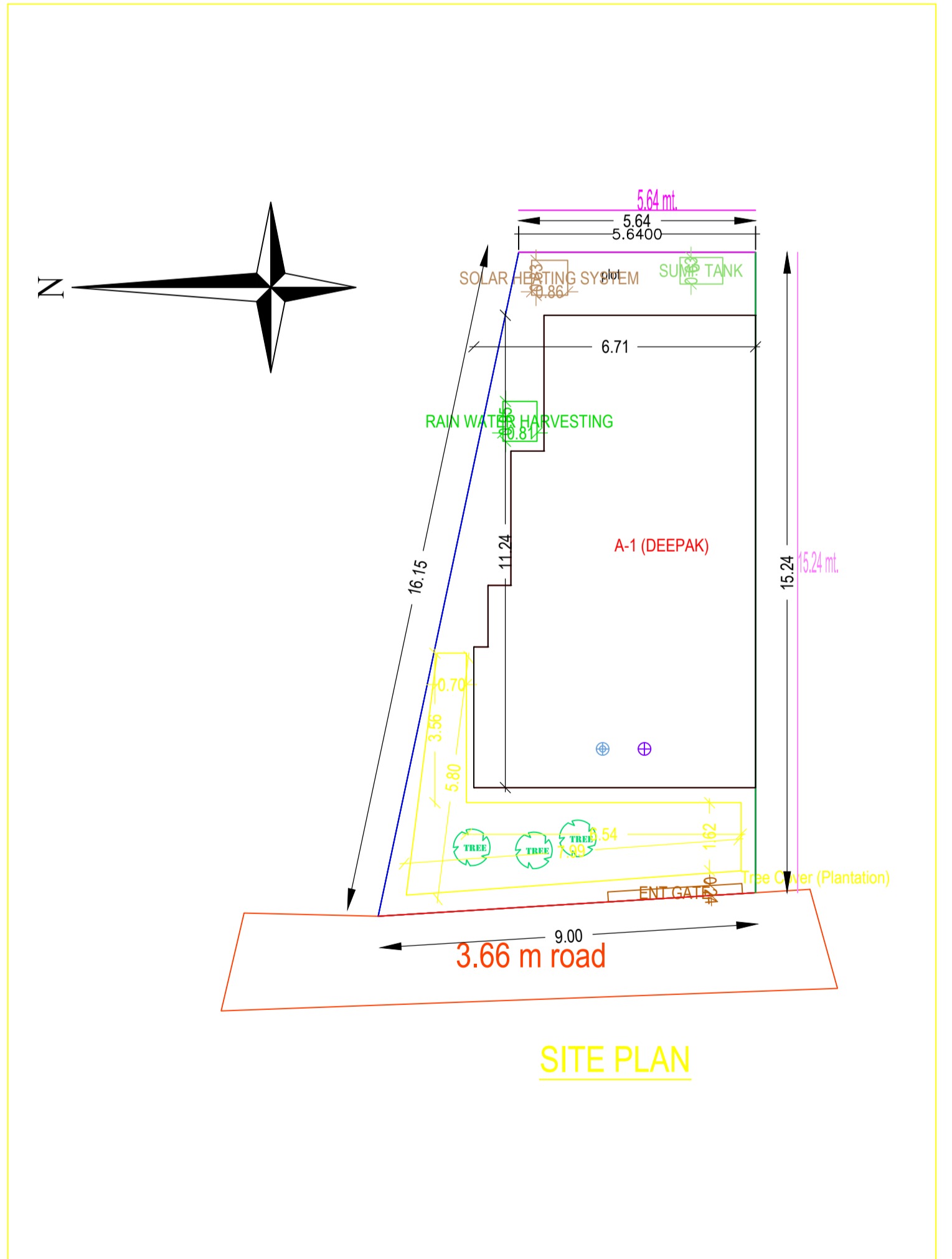
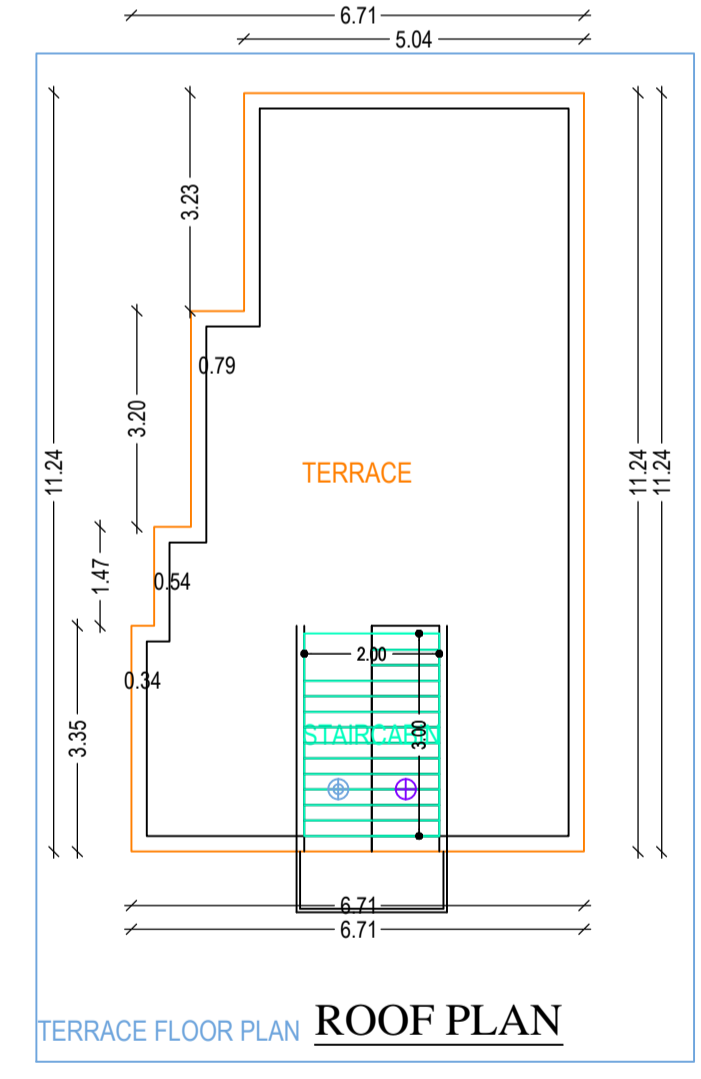
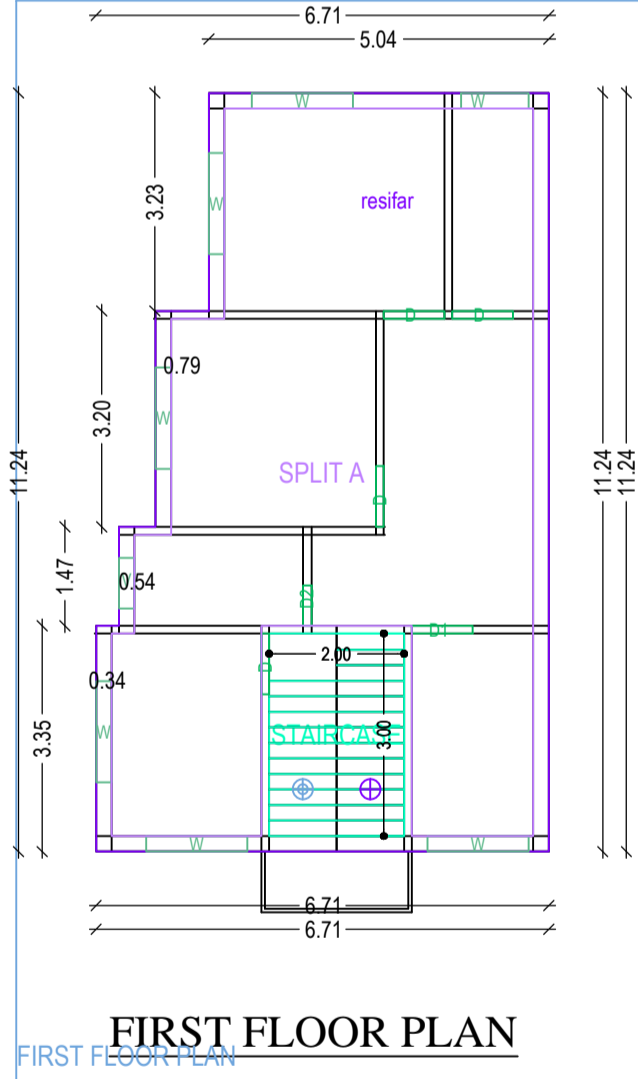
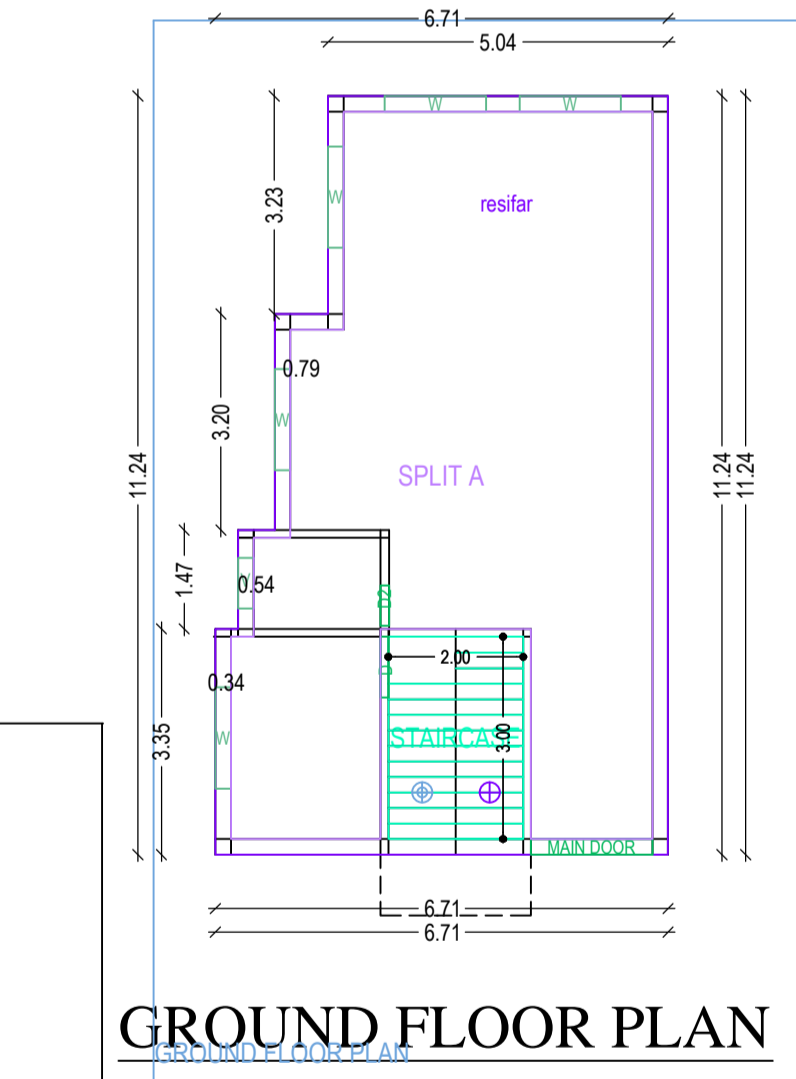
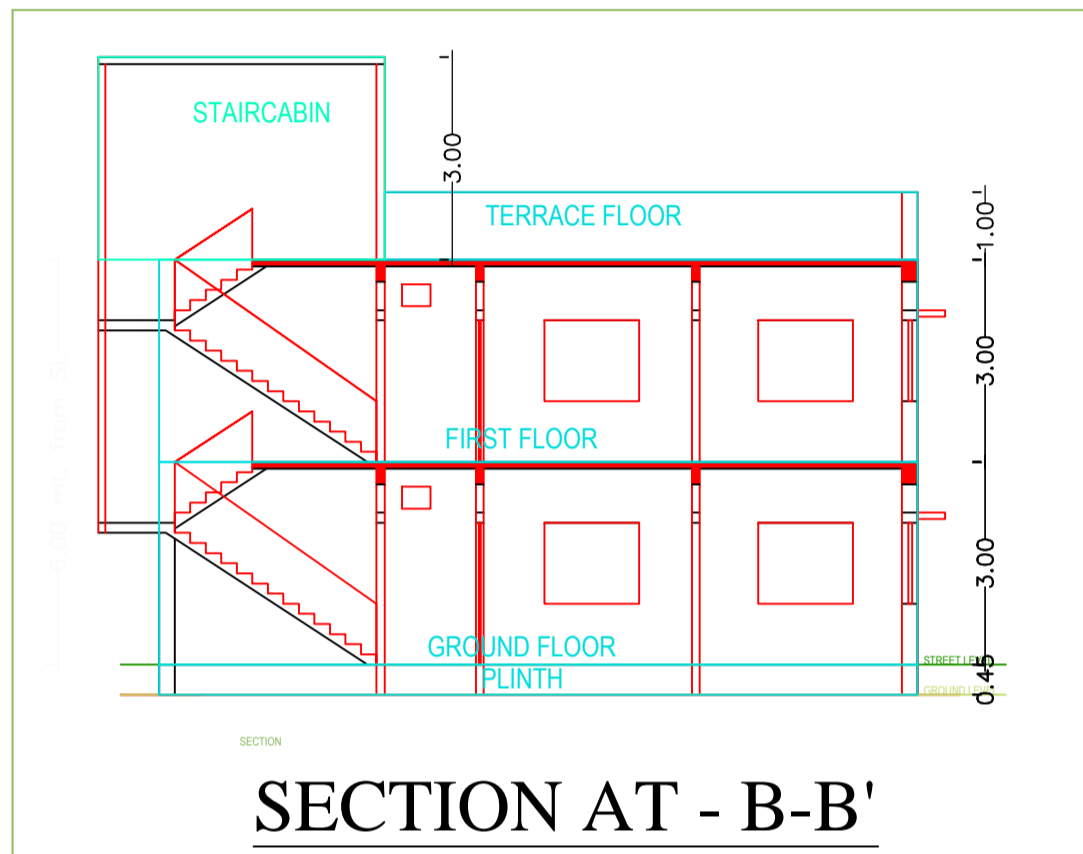
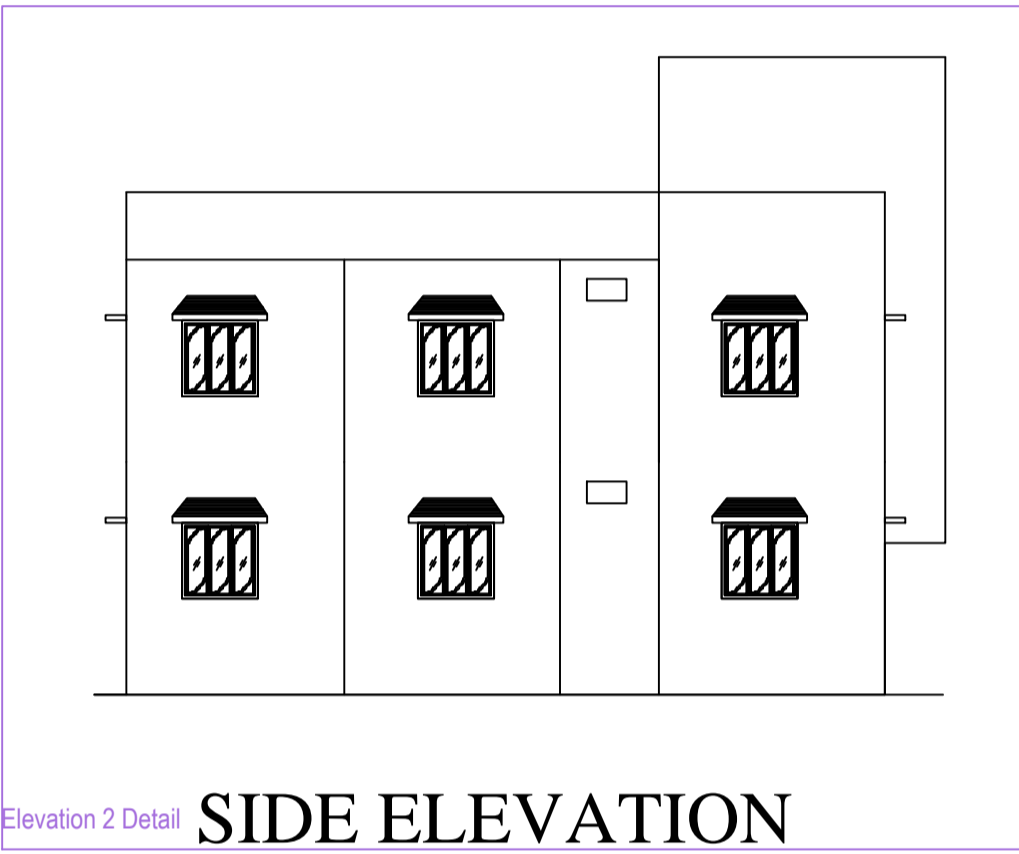
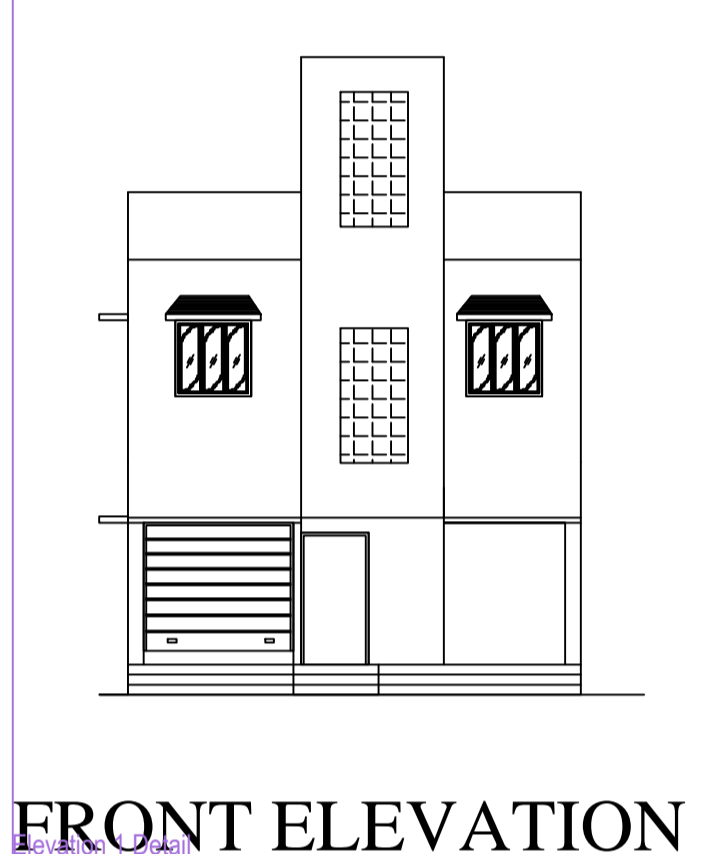
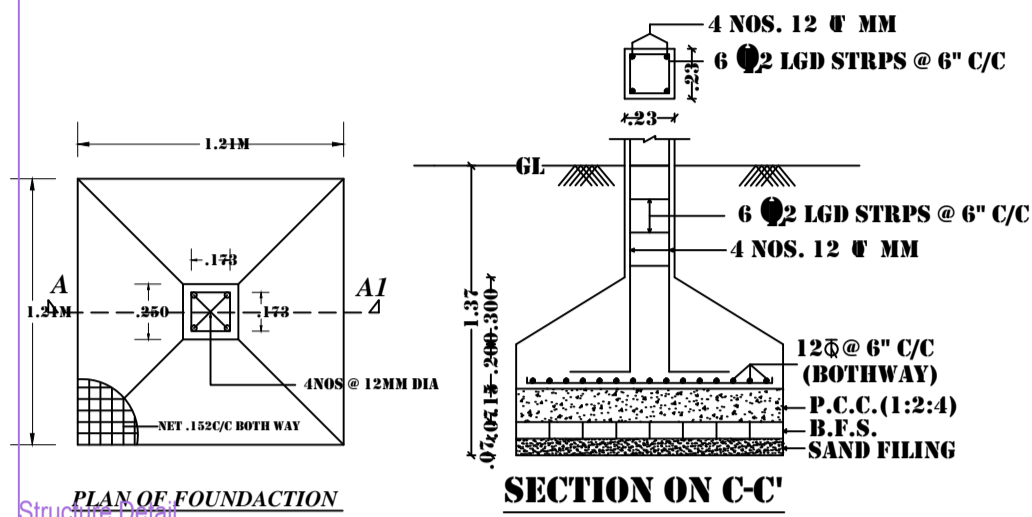
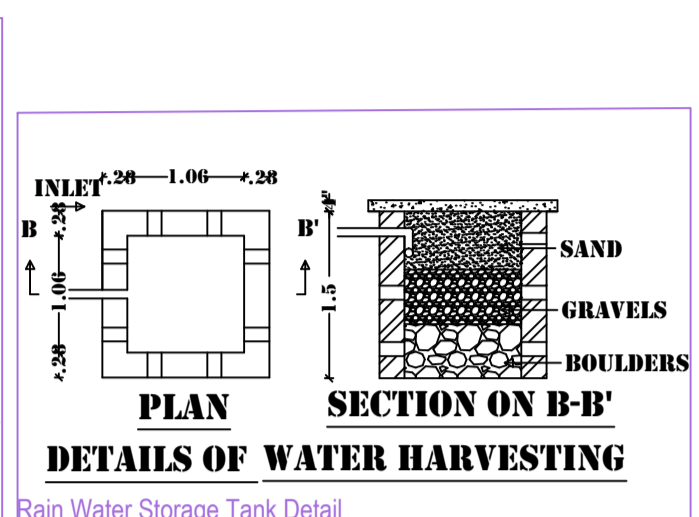
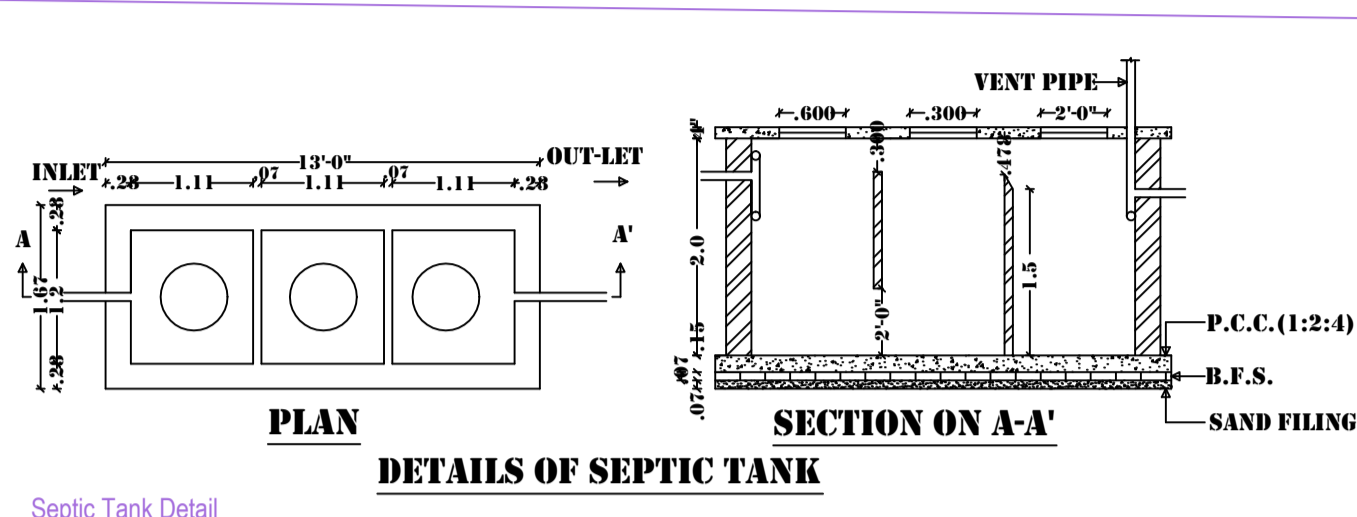

Building 'A' (DEEPAK)

Floor Name	Total Built Up Area (Sq.mt.)	Proposed FAR Area (Sq.mt.) Resi.	Total FAR Area (Sq.mt.)	Tnmt (No.)
Ground Floor...	66.69	66.69	66.69	01
First Floor...	66.69	66.69	66.69	00
Terrace Floor...	0.00	0.00	0.00	00
<b>Total :</b>	<b>133.38</b>	<b>133.38</b>	<b>133.38</b>	<b>01</b>
Total Number of Same Buildings	1			
<b>Total :</b>	<b>133.38</b>	<b>133.38</b>	<b>133.38</b>	<b>01</b>