

Project Title -1. DILIP RAMANI 2. JAYFESH RAMANI S/O- LATE HARI LAL KANJI RAMANI

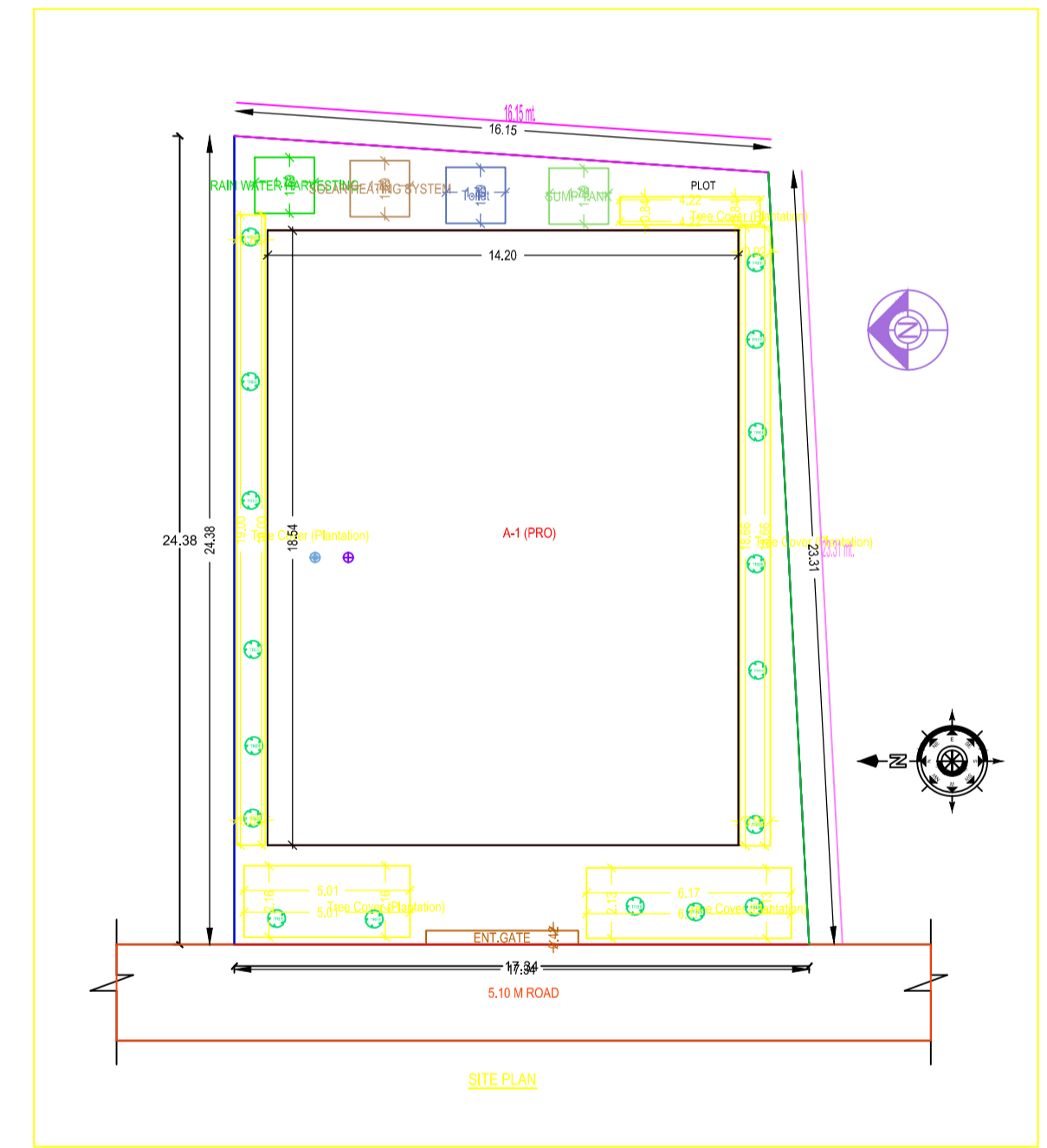
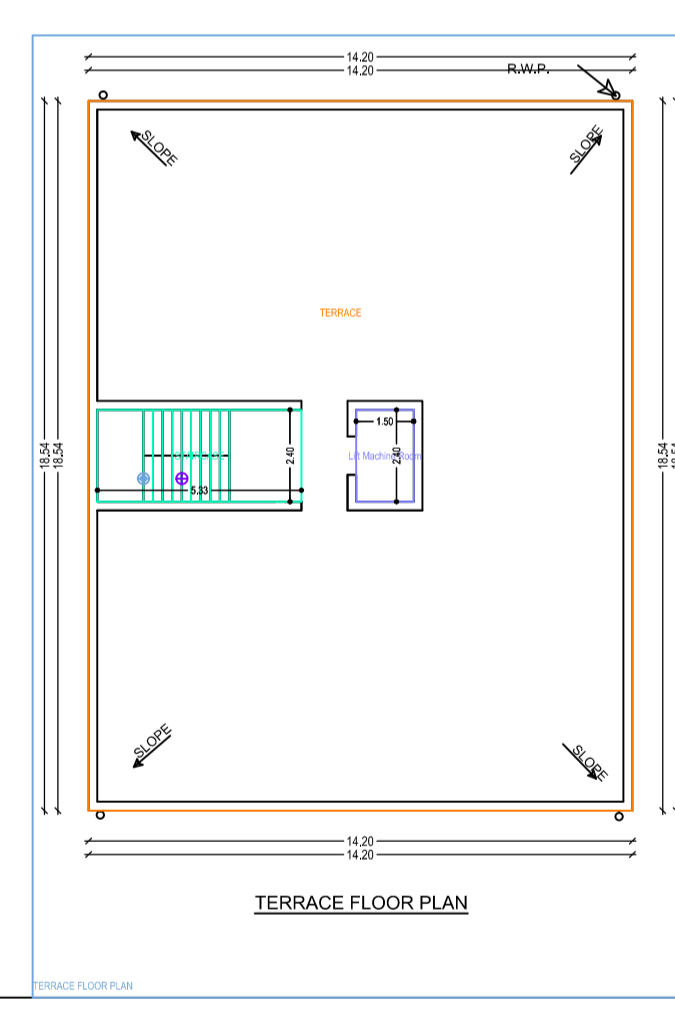
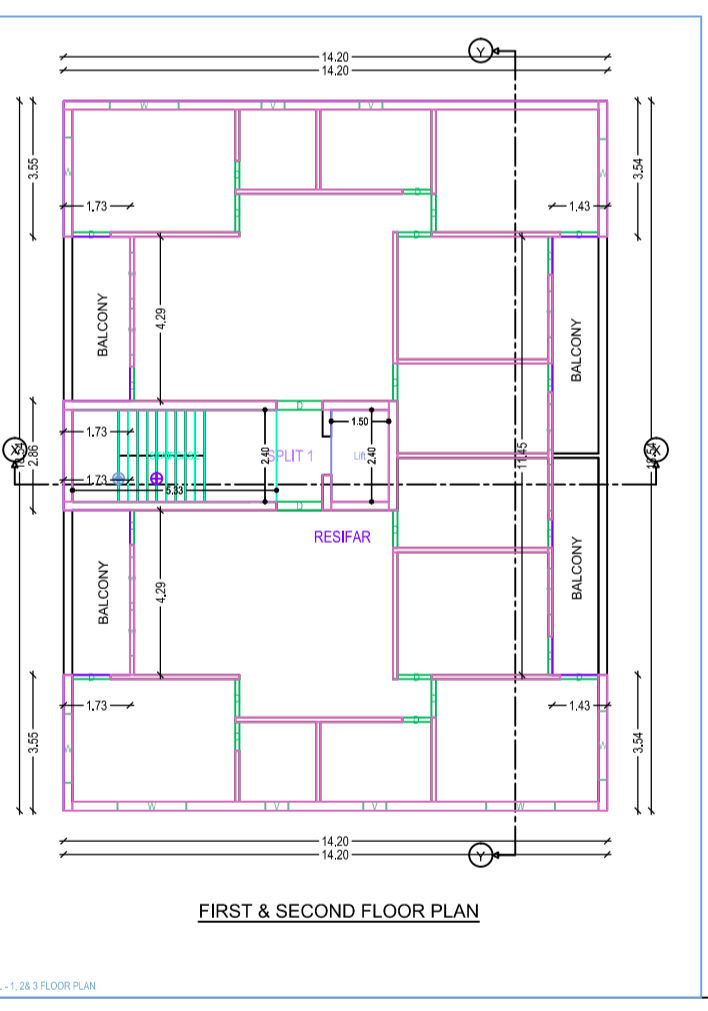
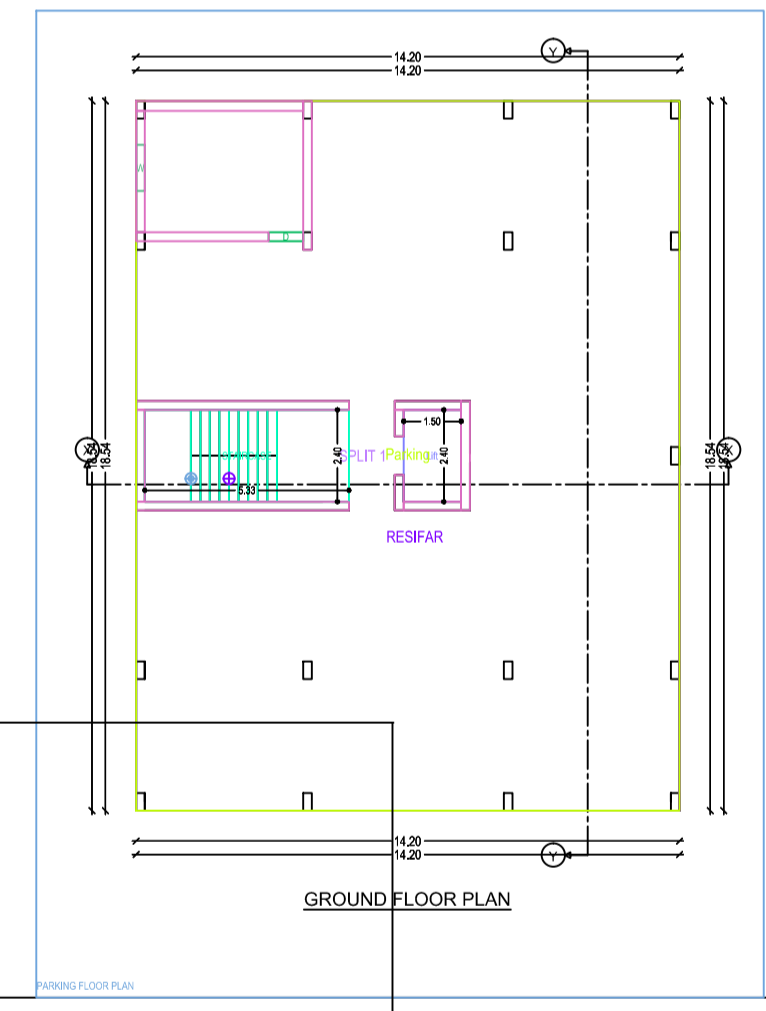
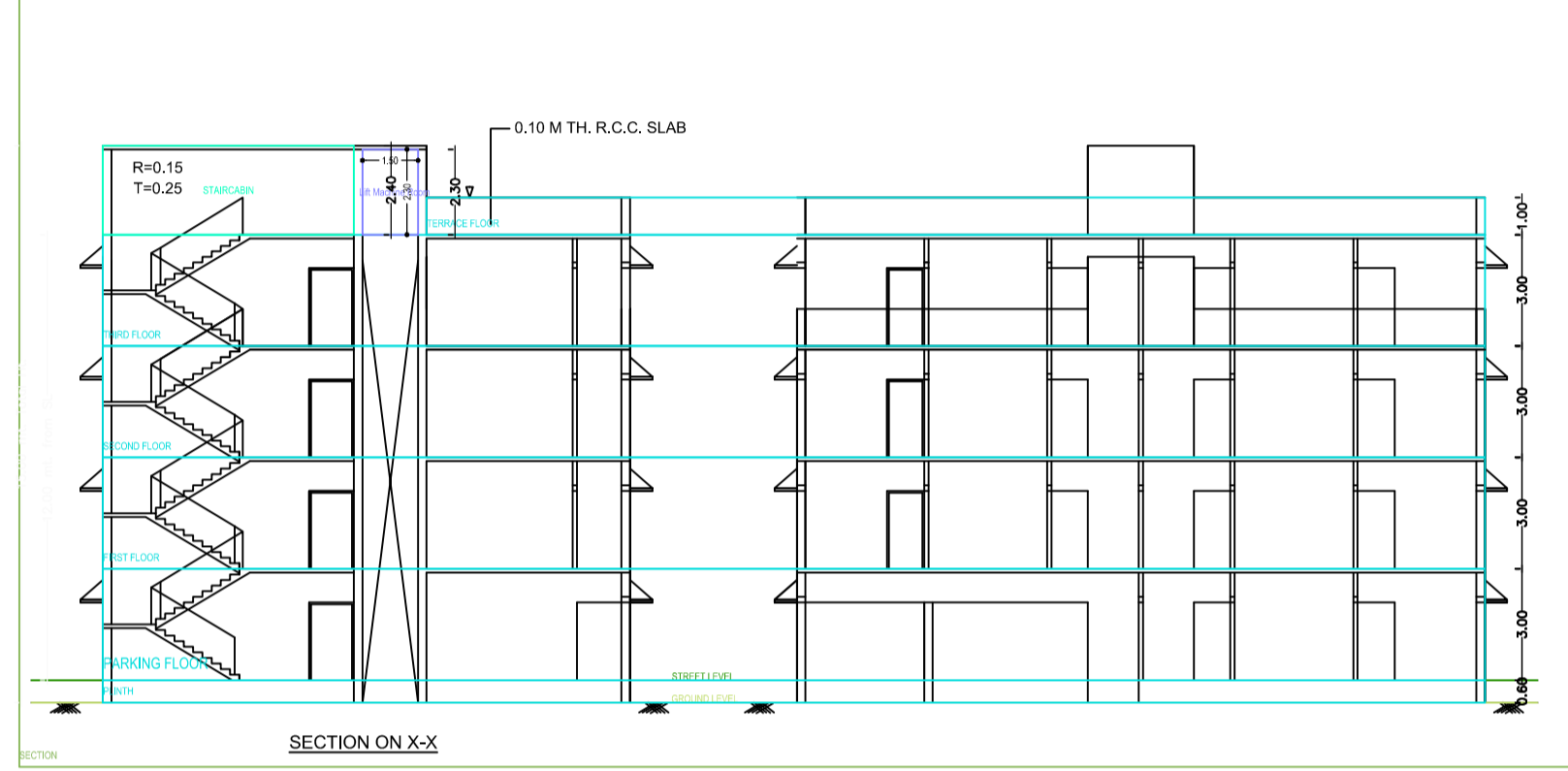
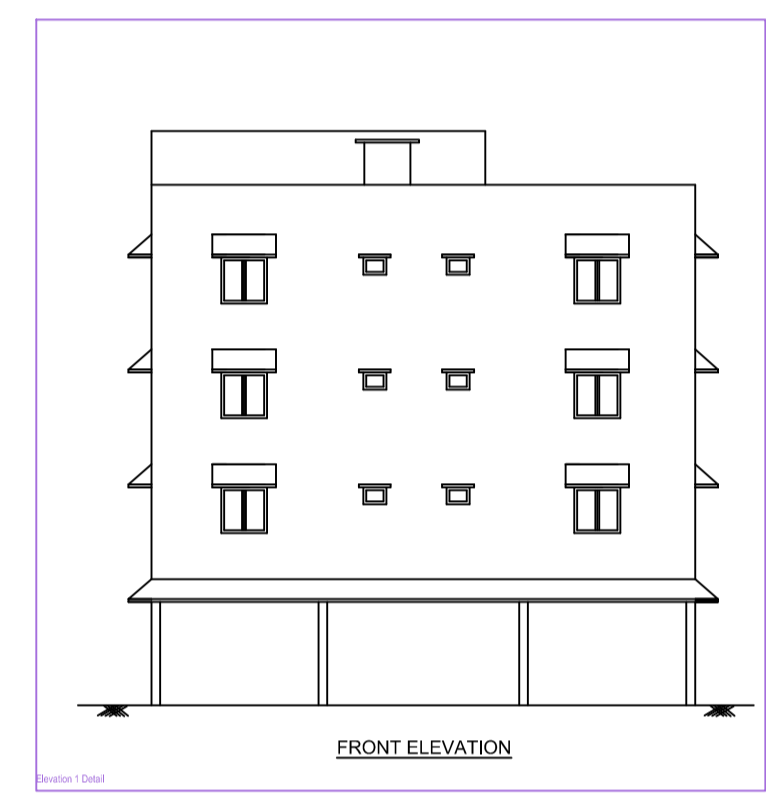
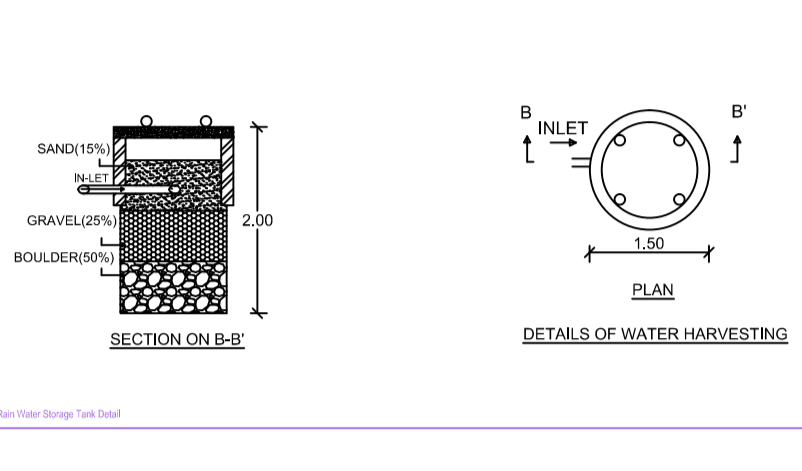
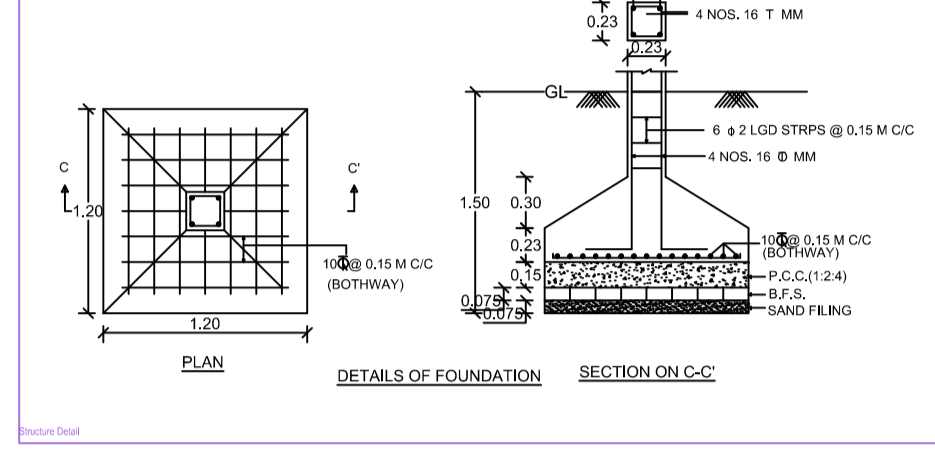
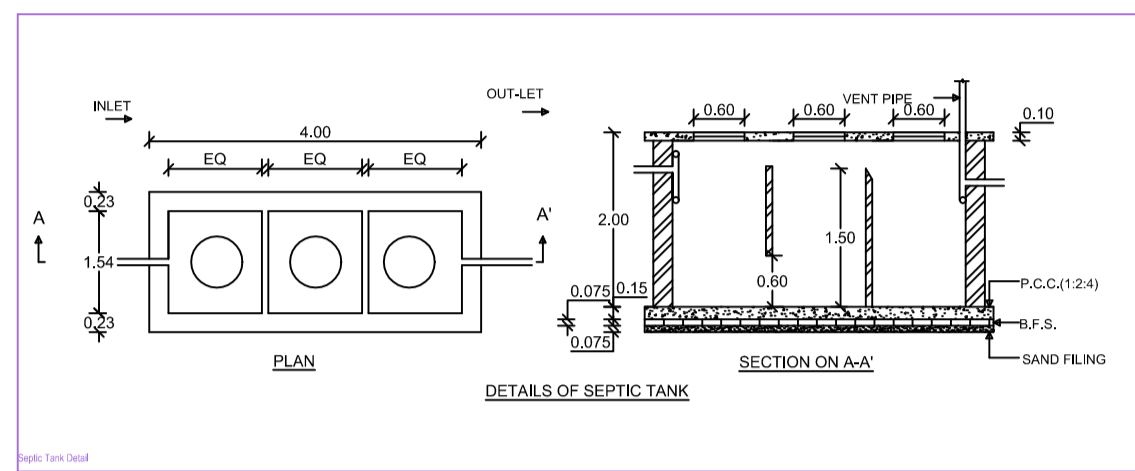

Building A (PRO)

Floor Name	Total Built Up Area (Sq.Mt.)	Occupancy Area (Sq.Mt.)	Proposed FFR Area (Sq.Mt.)	Total FFR Area (Sq.Mt.)	Time (Hrs)
Ground Floor	220.04	100	220.04	220.04	01
First Floor	220.04	100	220.04	220.04	01
Second Floor	220.04	100	220.04	220.04	01
Third Floor	220.04	100	220.04	220.04	01
Terrace Floor	220.04	100	220.04	220.04	01
Grand Total	1100.20	500	1100.20	1100.20	05

SCHEDULE OF JOINERY:

DESCRIPTION	UNIT	LENGTH	HEIGHT	NO.
X-PROG	m	1.75	2.10	01
X-PROG	m	1.50	2.10	01
X-PROG	m	1.50	2.10	01
X-PROG	m	1.50	2.10	01
X-PROG	m	1.50	2.10	01
X-PROG	m	1.50	2.10	01
Total	m	8.25	2.10	06

SCHEDULE OF JOINERY:

DESCRIPTION	UNIT	LENGTH	HEIGHT	NO.
X-PROG	m	1.50	2.10	01
X-PROG	m	1.50	2.10	01
X-PROG	m	1.50	2.10	01
Total	m	4.50	2.10	03

UNIT/EA Table for Building A (PRO)

FLOOR	Area	UNIT/EA	UNIT/EA Area	Cover Area	No. of Rooms	No. of Bathrooms
PARKING	841.11	FLAT	488.10	487.87	1	1
LANDSCAPE	-	-	488.10	487.87	01	1

AREA/PERCENT OF MUNICIPAL CORPORATION

DESCRIPTION	Area (Sq.Mt.)	Percentage (%)
Plot Area	1100.20	100.00
Area for Building	1100.20	100.00
Area for Road	-	-
Area for Green Space	-	-
Area for Water Body	-	-
Area for Other	-	-
Total	1100.20	100.00

COLOR INDEX

Color Index Table with columns for Color Name and Color Code.

PARKING CALCULATION

Category	No. of Vehicles	Area (Sq.Mt.)
Car	10	200.00
Two Wheeler	5	50.00
Total	15	250.00

FAR & Tenement Details (Table-6-1)

Category	No. of Units	Total Built Up Area (Sq.Mt.)	Proposed FFR Area (Sq.Mt.)	Total FFR Area (Sq.Mt.)	Time (Hrs)
X-PROG	1	1100.20	500.00	500.00	01
Grand Total	1	1100.20	500.00	500.00	01