

Project Title : SHAILENDRA KUMAR SRIVASTAVA S/O:-I ATE RADHA MOHAN PRASAD IN MOUZA:- CHAS P.S.- CHAS P.S. NO.-30,DIST:-ROKARO ,IHARKHAND ,INDER KHATA ,NO.-307 PI.OT. NO.-189

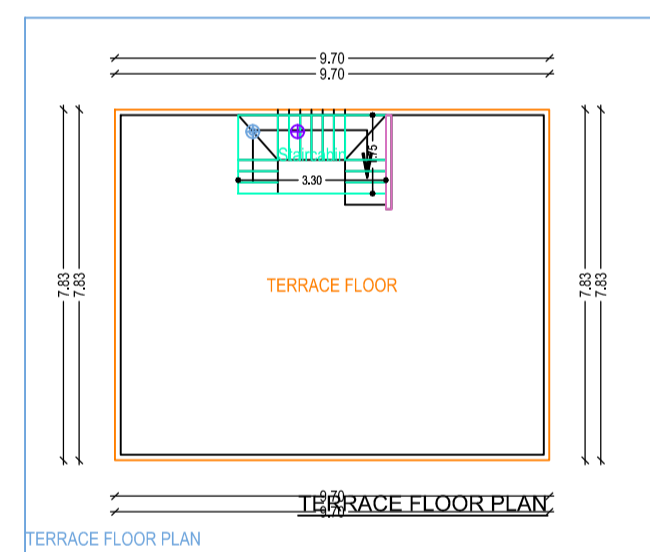
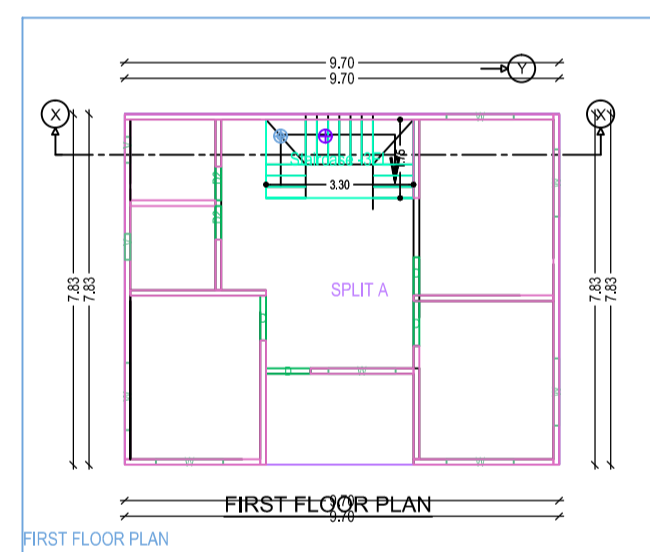
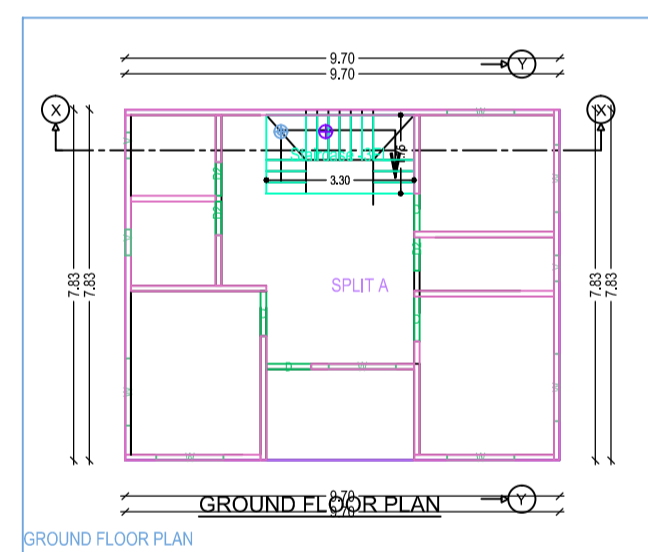
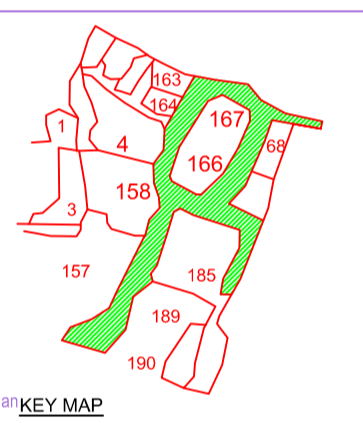
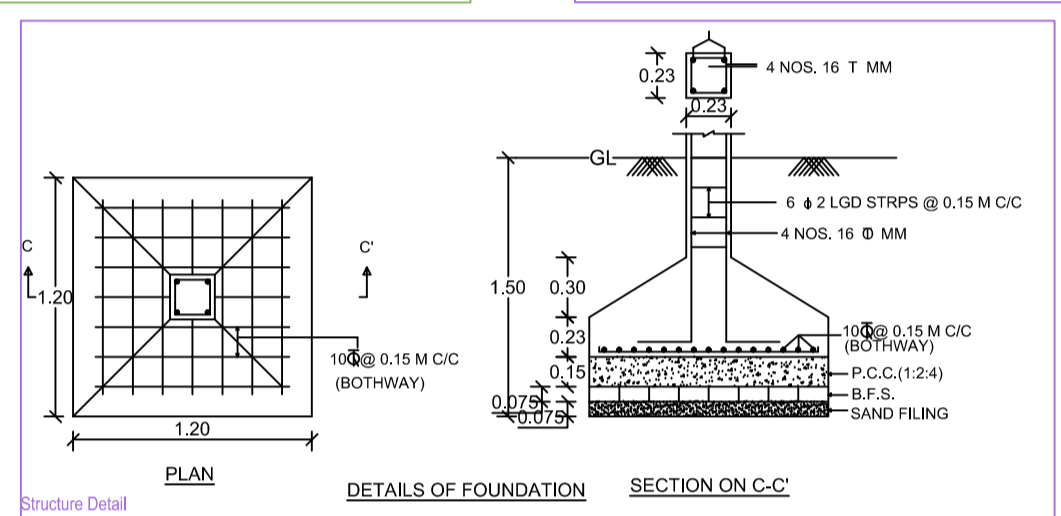
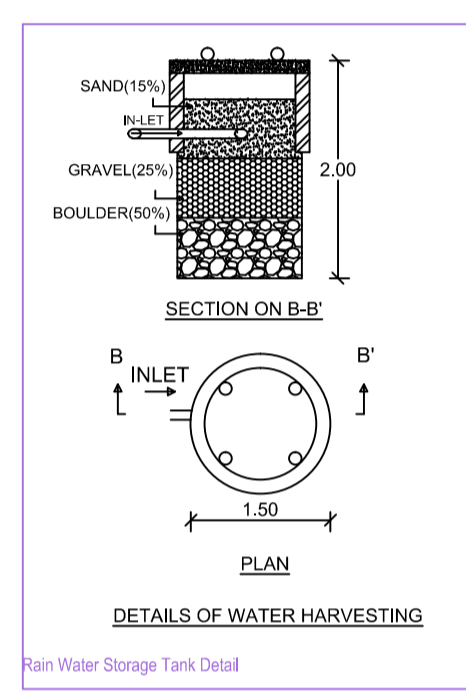
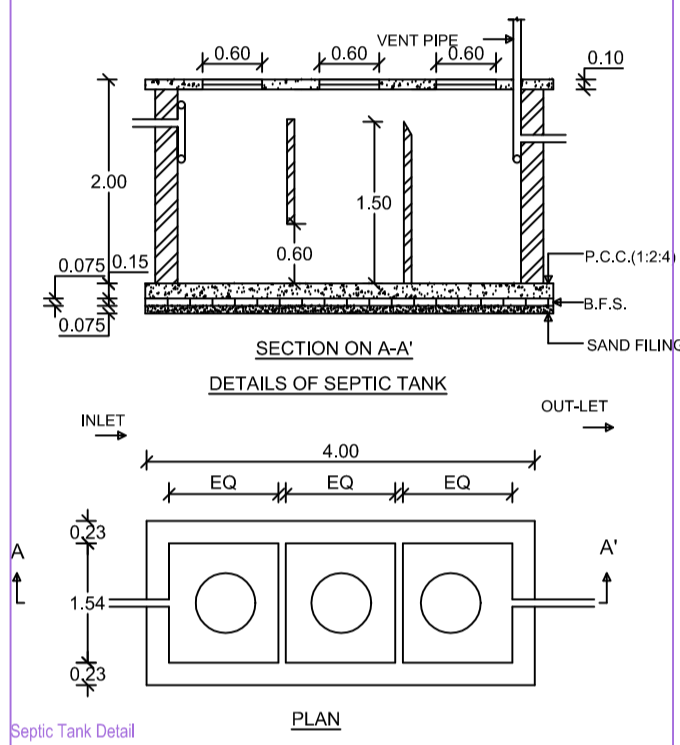
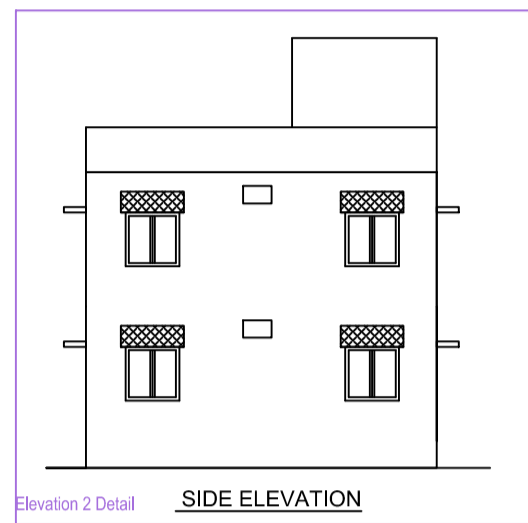
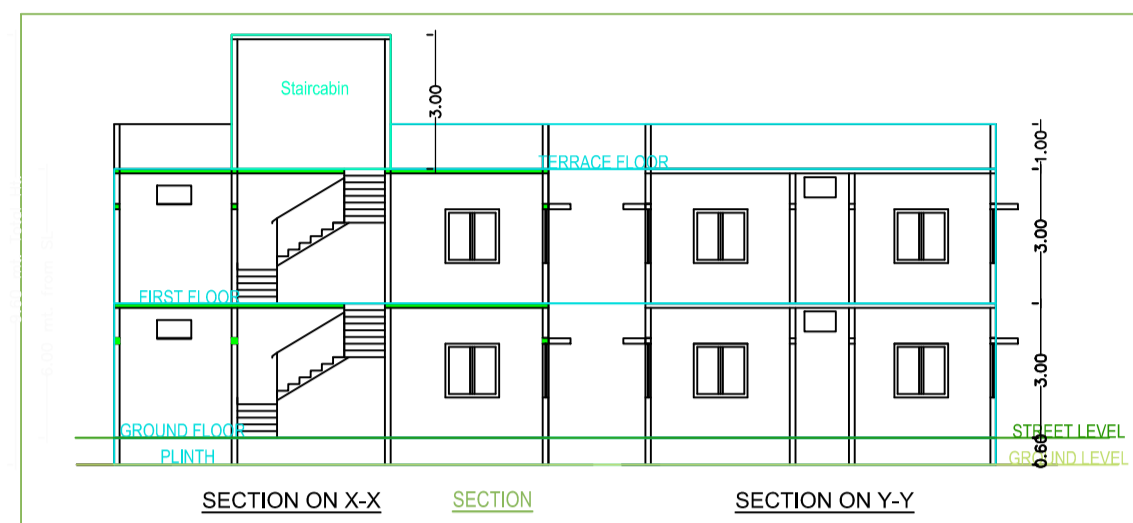
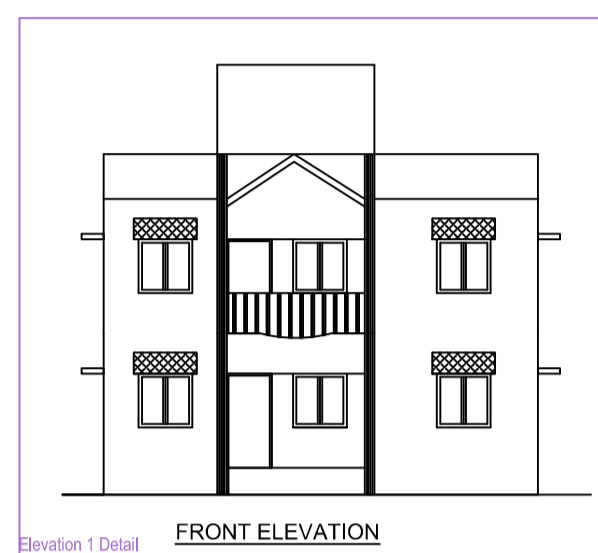

BRIEF SPECIFICATION

STEEL = Fe-500 Grade I.M.T Steel Shall be used.
 FOUNDATION = CEMENT CONCRETE(1:1.5:3)M20 Grade.
 SUPERSTRUCTURE = BRICK WORK IN CM(1:6)
 FLOORING = 25 MM I.P.S.MARBLE/MOSAIC OVER 3" THICK P.C.C.
 D.P.C. = 25 MM TH. D.P.C. IN CEMENT CONCRETE(1:1.5:3)
 PLINTH = 0.15 M TH. R.C.C. BAND ALL ROUND IN M20 CONCRETE
 LINTELS = 0.15 M TH. R.C.C. LINTEL IN M20 GRADE CONCRETE
 WOOD WORK = ALL WOOD WORK IN HARD WOOD.
 PLASTERING = 12mm TH. CEMENT PLASTER BOTH SIDE IN CM (1:6)
 FINISHING = FIRST CLASS APPROVED QUALITY.
 ANTITERMITE = ANTI TERMITE TREATMENT IN FLOOR SHALL BE DONE.
 WATER PROOFING = ROOF AND WALL SHALL BE OF WATER RESISTANT.
 DRAINAGE = ADEQUATE DRAINAGE SHALL BE PROVIDED.
 IS CODES = BUILDING CODE OF INDIA SHALL BE FOLLOWED.
 CEMENT = S3 GRADE PRODUCED FROM 'A' GRADE PLANT.
 WALL = OUTER(0.23 THICK) & INNER(0.12 THICK)

SCHEDULE OF OPENINGS

D =1.00X2.10 D1 =0.90X2.10 D2 =0.75X2.10
 W =1.20X1.20 W1 =0.90X1.20 V =0.60X0.45

SCHEDULE OF AREA

TITLE OF DRAWING

SIGNATURE OF OWNER

SIGNATURE OF ENGINEER

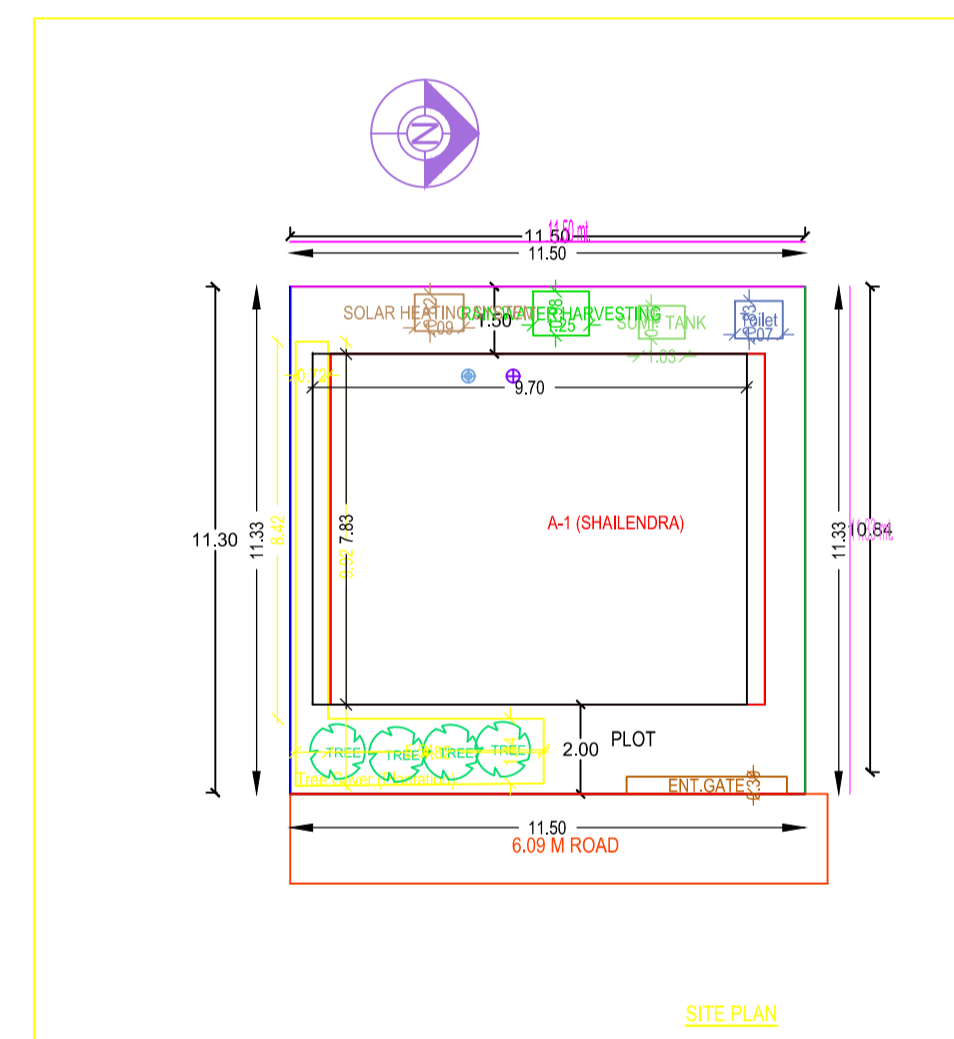

| | | |
|---|--|-------------------------|
| AREA STATEMENT OF MUNICIPAL CORPORATION | | VERSION NO. 1.0.11 |
| PROJECT SERIAL | | VERSION DATE 20/03/2018 |
| Project No. :- | Plot Use :- Residential | |
| Project Name :- SHAILENDRA URBAN LOCAL BODIES | Plot Sub-Use :- Residential (B)Apartment | |
| Project Location :- CHAS P.S. CHAS P.S. NO. 30, DIST. ROKARO, IHARKHAND | Land Use Zone :- NA | |
| Project Type :- General Proposal | Adjoining Road Width :- | |
| Project Location :- Building/Permissible | Plot No. :- | |
| Nature of Development :- New | Revenue Survey No./Survey No. :- | |
| Location :- CHAS P.S. | Thana No. :- | |
| Sub Location :- NA | Postage No. :- | |
| Village/Moosa Name :- | Khata No. :- | |
| Plot No. :- | North :- | |
| Plot Street :- | South :- | |
| | East :- | |
| | West :- | |

| | | | |
|--|----------------|--------|------------|
| AREA OF PLOT (Minimum) | (A) | SQ.MT. | 136.29 |
| Net Plot Area (Gross Plot Area) | (A-Deductions) | | 136.29 |
| Deductions for Balance Plot Area (Net Gross Plot Area) | | | |
| Plot Area | | | 14.21 |
| Total | | | 14.21 |
| Minimum Plot Area (Net Plot Area) | (A-Deductions) | | 116.08 |
| Plot Area for Coverage (Net Plot Area) | (A-Deductions) | | 136.29 |
| Plot Area for FSI (Net Plot Area) | (A-Deductions) | | 136.29 |
| Accessory Use Area | | | 6.88 |
| COVERAGE CHECK | | | |
| Proposed Coverage Area (GROSS %) | | | 75.35 |
| Total Coverage Area (GROSS %) | | | 75.35 |
| PERMIT CHECK | | | |
| Proposed Area of FAR | | | 151.30 |
| Total Area of FAR | | | 151.30 |
| BUILT UP AREA CHECK | | | |
| Net Proposed Built Up Area | | | 151.30 |
| PERMIT CHECK (PERMISSIBLE) (M2) | | | |
| OWNER | | | |
| DEVELOPMENT AUTHORITY | | | LOCAL BODY |

| Building / Plot / Sub-Plot | Road Name | Front Margin | Rear Margin | Side Margin | Subd Margin |
|----------------------------|-------------|--------------|-------------|-------------|-------------|
| SHAILENDRA | 6.09 M ROAD | 2.00 | 1.00 | 0.00 | 1.30 |

| Building | No. of Same Bldg | Total Built Up Area (Sq.m) | Proposed FAR Area (Sq.m) | Total FAR Area (Sq.m) | Trees (No.) |
|--------------------|------------------|----------------------------|--------------------------|-----------------------|-------------|
| SHAILENDRA | 1 | 151.30 | 151.30 | 151.30 | 01 |
| Grand Total | 1 | 151.30 | 151.30 | 151.30 | 01 |

Building A (SHAILENDRA)

| Floor Name | Total Built Up Area (Sq.m) | Proposed FAR Area (Sq.m) | Total FAR Area (Sq.m) | Trees (No.) |
|--------------------------------|----------------------------|--------------------------|-----------------------|-------------|
| Ground Floor | 79.93 | 79.93 | 79.93 | 01 |
| First Floor | 79.93 | 79.93 | 79.93 | 02 |
| Terrace Floor | 0.00 | 0.00 | 0.00 | 00 |
| Total | 159.86 | 159.86 | 159.86 | 03 |
| Total Number of Same Buildings | 1 | | | |
| Total | 159.86 | 159.86 | 159.86 | 03 |

SCHEDULE OF JOINERY:

| BUILDING NAME | NAME | LENGTH | HEIGHT | NOSE |
|----------------|------|--------|--------|------|
| A (SHAILENDRA) | W | 1.20 | 2.10 | 02 |
| A (SHAILENDRA) | D | 1.00 | 2.10 | 02 |
| A (SHAILENDRA) | D | 1.00 | 2.10 | 02 |
| Total | | | | 06 |

SCHEDULE OF JOINERY:

| BUILDING NAME | NAME | LENGTH | HEIGHT | NOSE |
|----------------|------|--------|--------|------|
| A (SHAILENDRA) | V | 1.50 | 1.20 | 02 |
| A (SHAILENDRA) | W | 1.20 | 1.20 | 04 |
| Total | | | | 06 |

Unit/UA Table for Building A (SHAILENDRA)

| FLOOR | Name | Unit/UA Type | Unit/UA Area | Carpet Area | No. of Rooms | No. of Toilet |
|-------------------|---------|--------------|--------------|-------------|--------------|---------------|
| GROUND FLOOR PLAN | SPLIT A | FLAT | 151.30 | 136.83 | 3 | 1 |
| Total | | | 151.30 | 136.83 | 3 | 1 |