

SECTION ON Y-Y

SECTION ON X-X

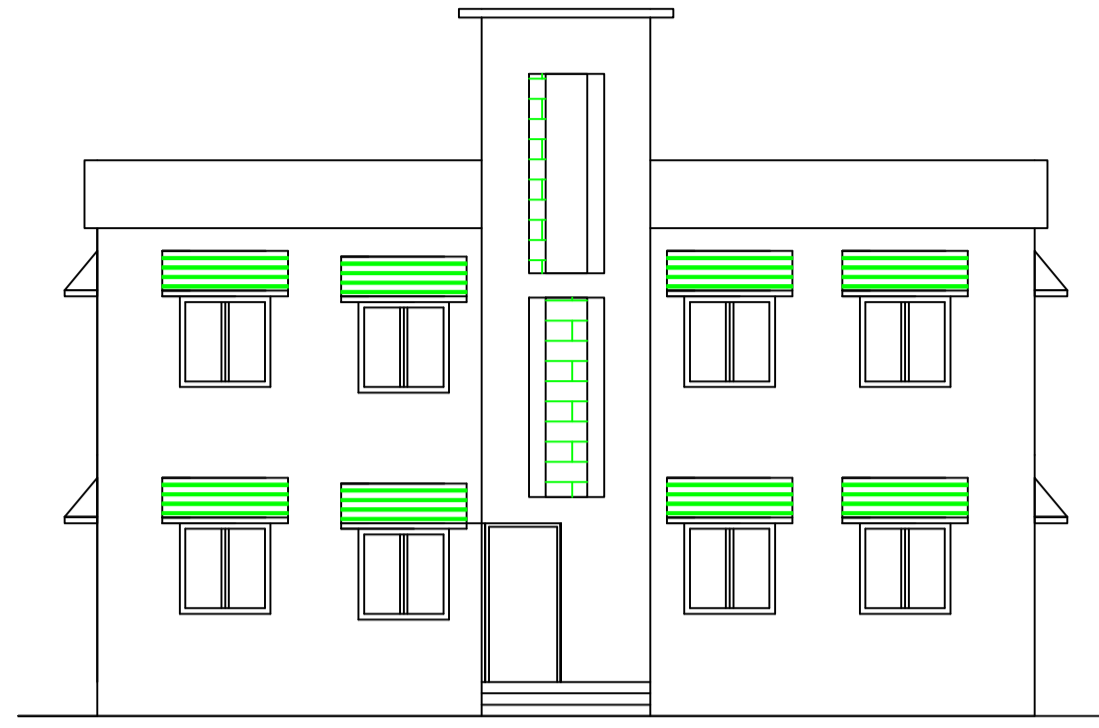

FRONT ELEVATION

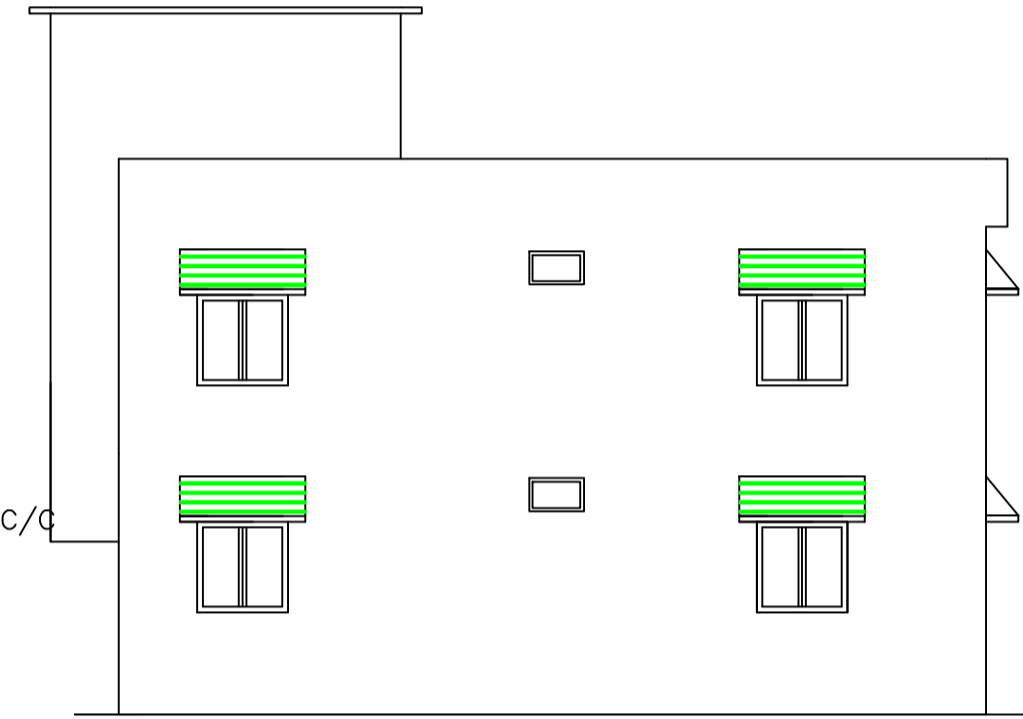

SIDE ELEVATION

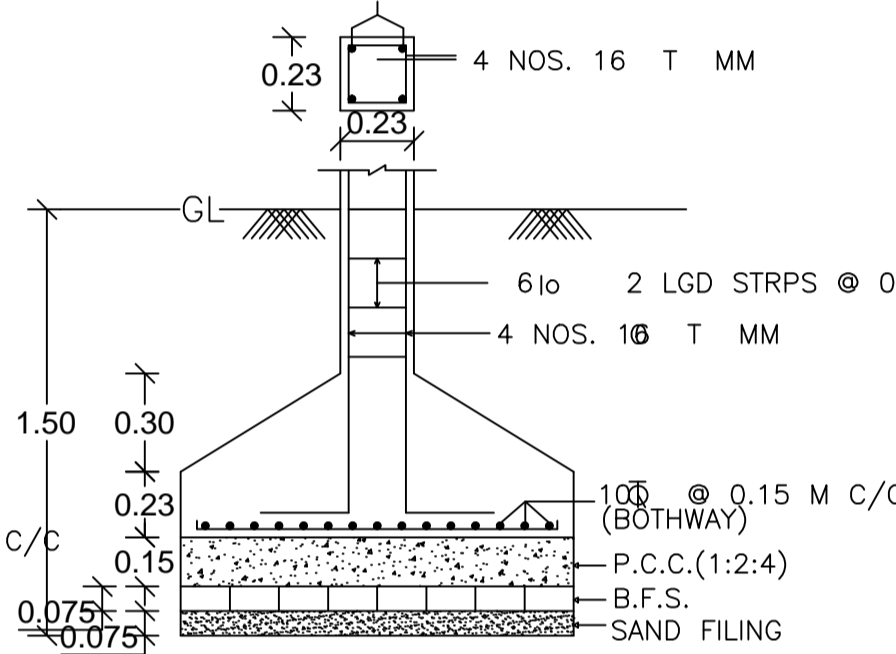
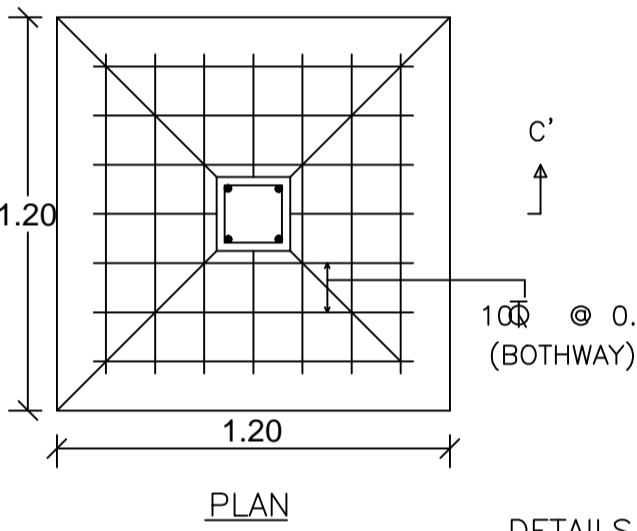
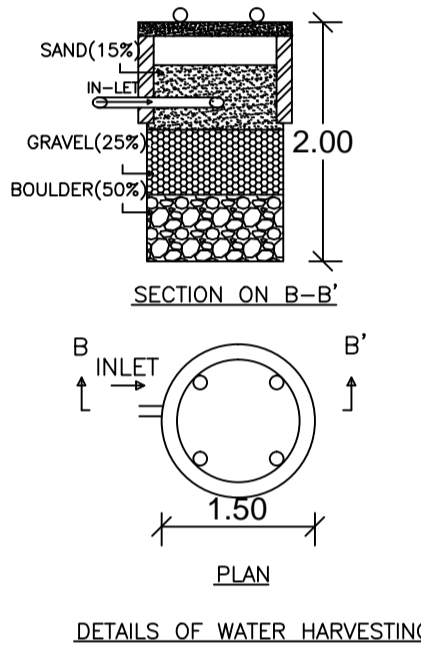
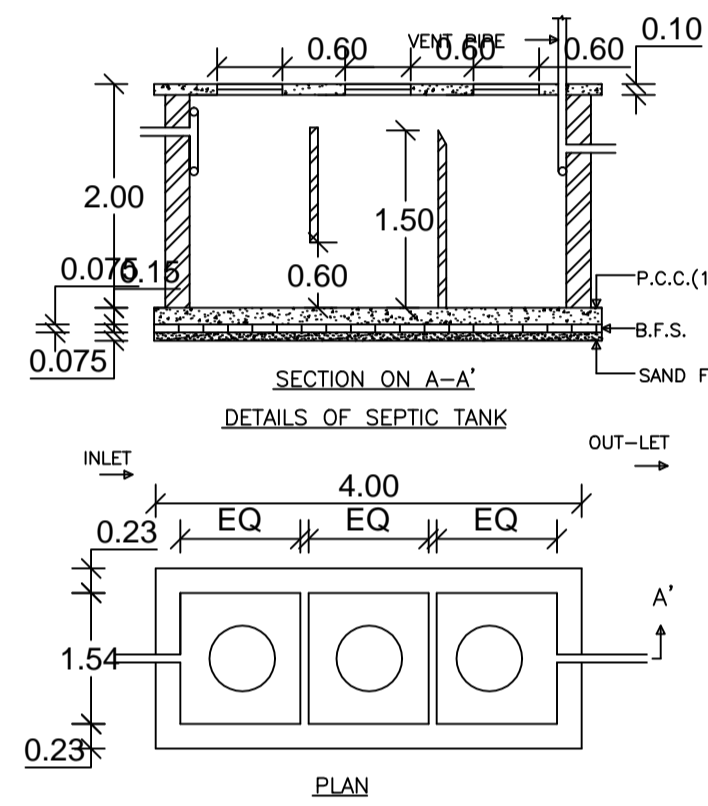

DETAILS OF FOUNDATION SECTION ON C-C'

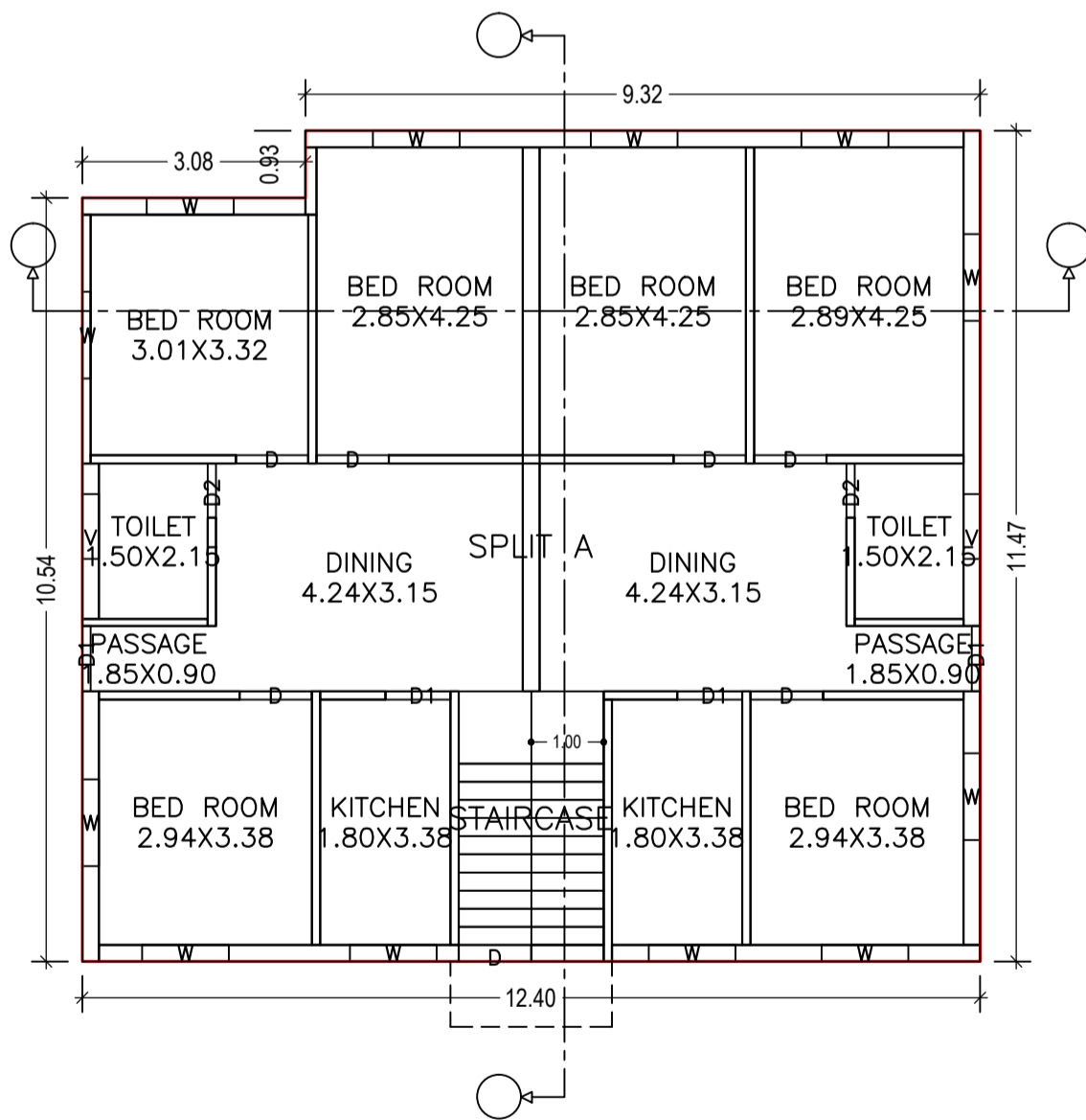

GROUND FLOOR PLAN (Proposed) (SCALE 1:100)

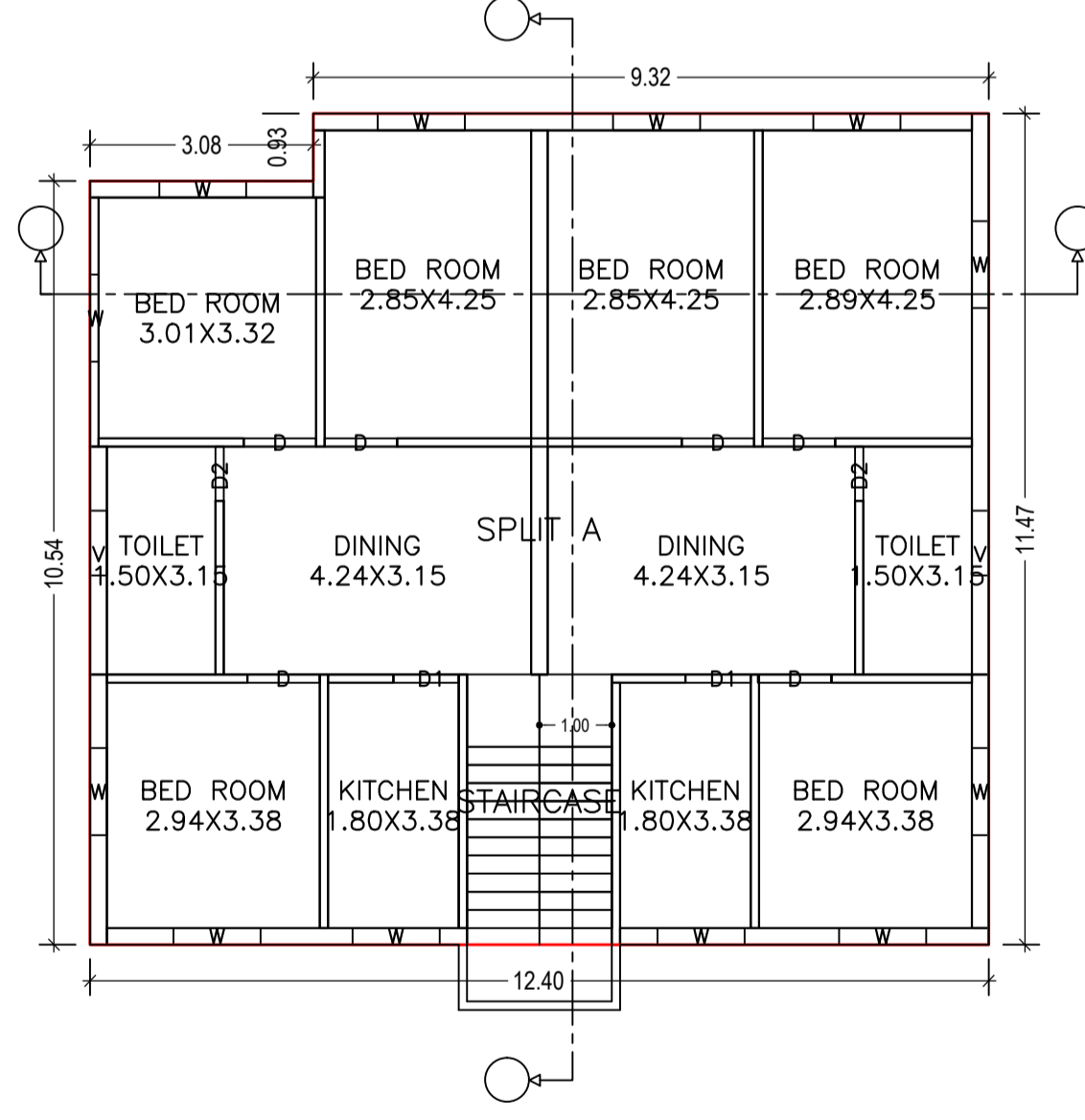

FIRST FLOOR PLAN (Proposed) (SCALE 1:100)

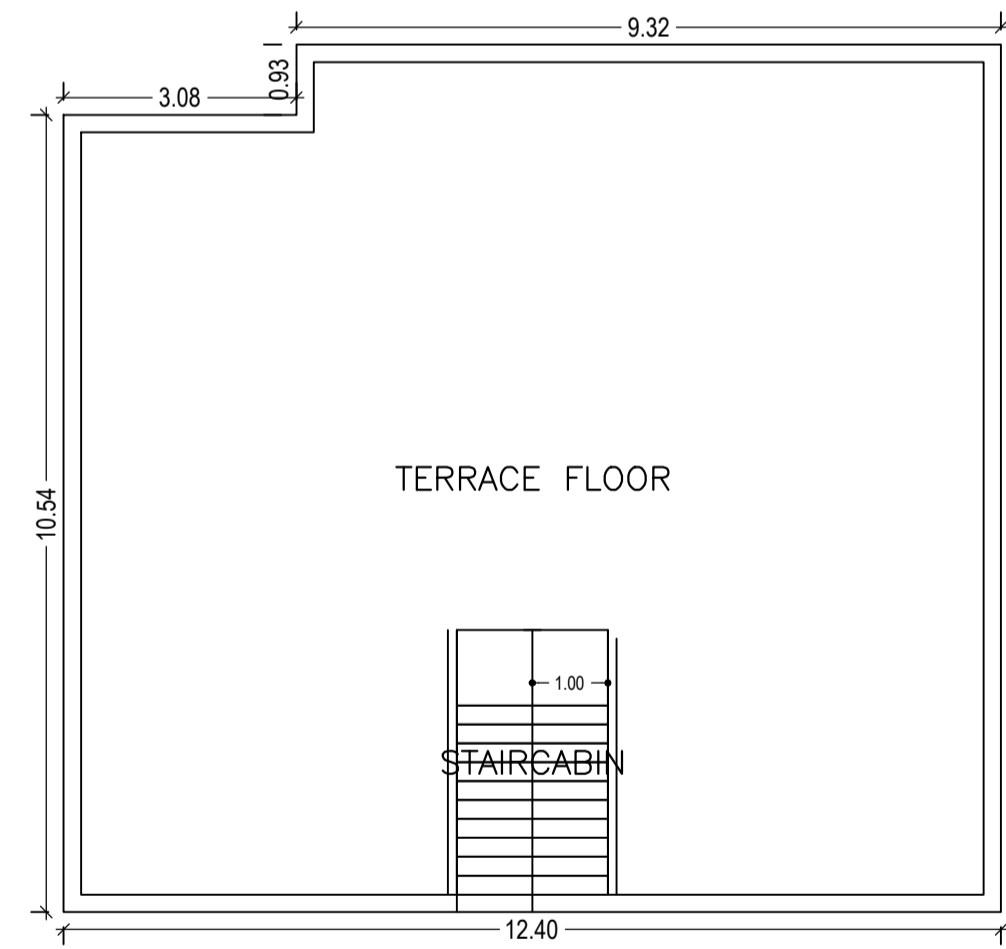

TERRACE FLOOR PLAN (SCALE 1:100)

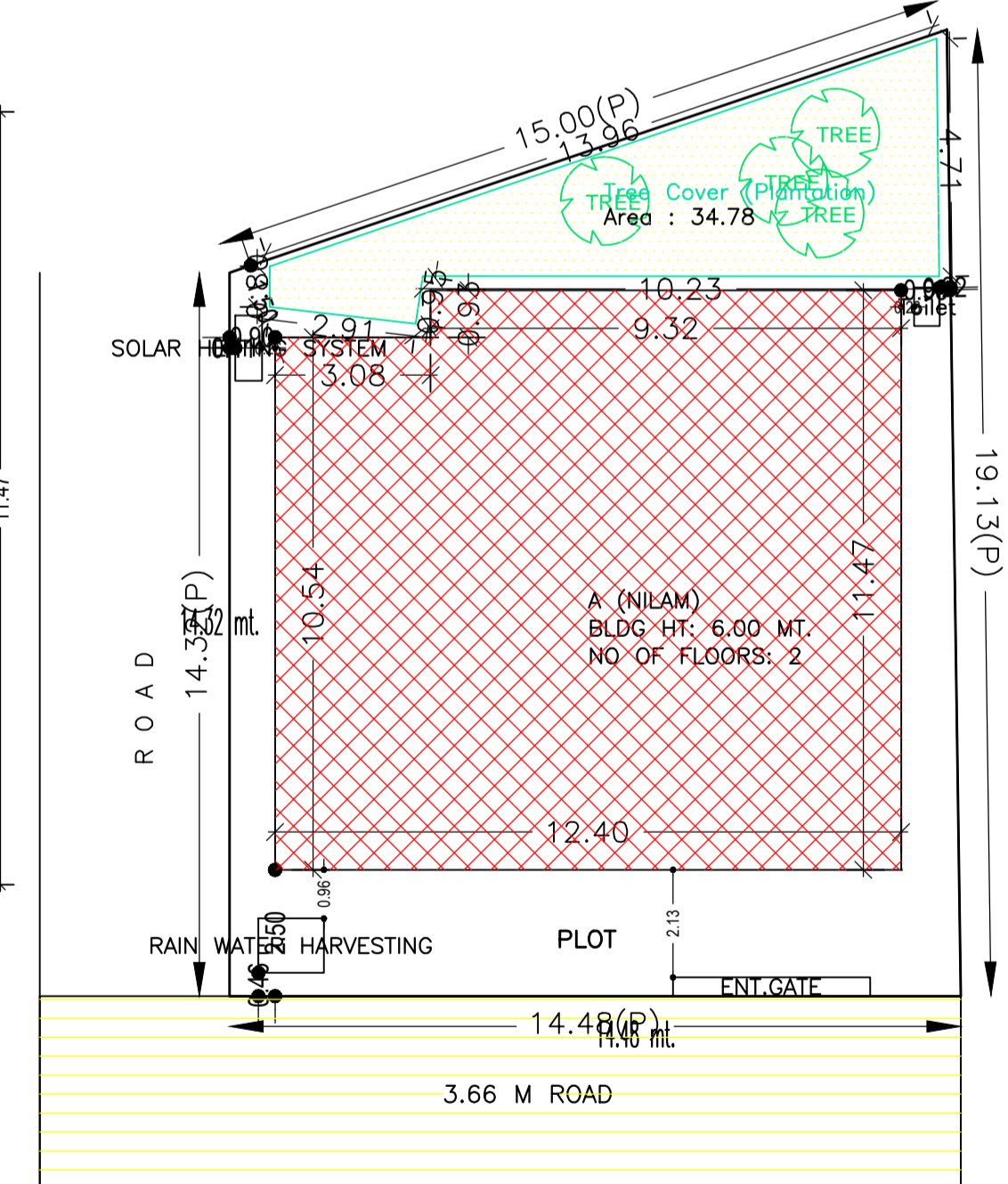

SITE PLAN

AREA STATEMENT CHAS MUNICIPAL CORPORATION	VERSION NO.: 1.0.21
PROJECT DETAIL:	VERSION DATE: 28/09/2017
Region: JHARKHAND URBAN	Plot Use: Residential
LOCAL BODIES	Plot SubUse: Bungalow/ Dwelling / Non Apartment
District: BOKARO	PlotNearbyReligiousStructure: NA
Authority: CHAS MUNICIPAL CORPORATION	PlotSubPlot No: 7355,7356
Inward No: CMC/BP/0055/W27/2018	North: CTS No. - kanak lata singh
Application Type: General Proposal	South: Road Width - road 3.66 m
Project Type: Building Permission	East: CTS No. - kabita jha
Nature of Development: New	West: Road Width - road 3.66
Location of Development Area: Old Area	
AREA DETAIL S:	SQ.MT.
NET AREA OF PLOT (Minimum)	240.22
NET AREA OF PLOT (Gross Plot Area - Deduction from Gross Plot area)	240.22
Deduction for Balance Plot Area (from Gross Plot Area)	
Common Plot	34.78
Total	34.78
BALANCE AREA OF PLOT (Net Plot Area - Recreational/Amenity space)	205.44
PLOT AREA FOR COVERAGE (Net Plot Area)	240.22
Plot Area for FAR (Net Plot Area + Road Widening Area)	240.22
COVERAGE CHECK	
Permissible Coverage area (60.00 %)	144.13
Proposed Coverage Area (58.02 %)	139.38
Total Prop. Coverage Area (58.02 %)	139.38
Balance coverage area (1.98 %)	4.75
FAR CHECK	
Perm. FAR Area (1.50)	360.33
Total Perm. FAR area	360.33
Residential FAR	278.75
Proposed FAR Area	278.75
Total Proposed FAR Area	278.75
Consumed FAR (Factor)	1.16
Balance FAR Area	81.58
BUILT UP AREA CHECK	
Total Proposed BuiltUp Area	278.76
ARCHITECT (Regd)	RAVI KUMAR
ENGINEER (Regd)	
SUPERVISOR (Regd)	NILAM DEVI
OWNER (Regd)	
DEVELOPMENT AUTHORITY	LOCAL BODY

Floor Name	Total Built Up Area (Sq.mt.)	Proposed FAR Area (Sq.mt.) Resi.	Total FAR Area (Sq.mt.)	Total Consumed Additional FAR Area (Sq.mt.)	Tnmt (No.)
Ground Floor	139.38	139.38	139.38	139.38	01
First Floor	139.38	139.38	139.38	139.38	00
Terrace Floor	0.00	0.00	0.00	0.00	00
Total :	278.76	278.76	278.76	278.76	01
Total Number of Same Buildings :					
Total :	278.76	278.76	278.76	278.76	01

FLOOR	Name	UnitBUA Type	UnitBUA Area	Carpet Area	No. of Rooms	No. of Tenement
GROUND FLOOR PLAN	SPLIT A	FLAT	278.75	246.48	14	1
FIRST FLOOR PLAN	SPLIT A	FLAT	0.00	0.00	12	0
Total :	-	-	278.75	246.48	26	1

NAME	LENGTH	HEIGHT	NOS
A (NILAM) D2	0.75	2.10	04
A (NILAM) D1	0.90	2.10	06
A (NILAM) D	1.00	2.10	12

NAME	LENGTH	HEIGHT	NOS
A (NILAM) V	0.89	1.20	04
A (NILAM) W	1.20	1.20	24

Color	Description
Black	PLOT BOUNDARY
Red	ABUTTING ROAD
Green	PROPOSED CONSTRUCTION
Blue	COMMON PLOT
Yellow	ROAD WIDENING AREA
Orange	EXISTING (To be retained)
Purple	EXISTING (To be demolished)

Building	No. of Same Bldg	Total Built Up Area (Sq.mt.)	Proposed FAR Area (Sq.mt.) Resi.	Total FAR Area (Sq.mt.)	Total Consumed Additional FAR Area (Sq.mt.)	Tnmt (No.)
A (NILAM)	1	278.76	278.76	278.76	278.76	01
Grand Total :	1	278.76	278.76	278.76	278.76	01

Building USE/SUBUSE Details

Building Name	Building Use	Building SubUse	Building Structure
A (NILAM)	Residential	Bungalow/ Dwelling / Non Apartment	Non-Highrise

Buildingwise Floor FAR Details

Floor Name	Building Name A (NILAM)		Total	
	Proposed Built Up Area (Sq.mt.)	Proposed FAR Area (Sq.mt.)	Total Proposed Built Up Area (Sq.mt.)	Total FAR Area (Sq.mt.)
Ground Floor	139.38	139.38	139.38	139.38
First Floor	139.38	139.38	139.38	139.38
Terrace Floor	0.00	0.00	0.00	0.00
Total :	278.76	278.76	278.76	278.76

LTP NAME AND SIGNATURE	STRUCTURAL ENG'S NAME AND SIGNATURE	BUILDER NAME AND SIGNATURE
RAVI KUMAR CMC/DFTMN/0024/2017		