

Project Title - 1 SRI SUDHAKAR 2 SRI PRABHAKAR 3 SRI RATNAKAR S/O SRI DHANANJAY KUMAR SINGH IN MOUZA- CHAS P.S. CHAS NO - 30 DIST- ROKARQ UNDER KHATA NO - 307 PI.OT NO - 190

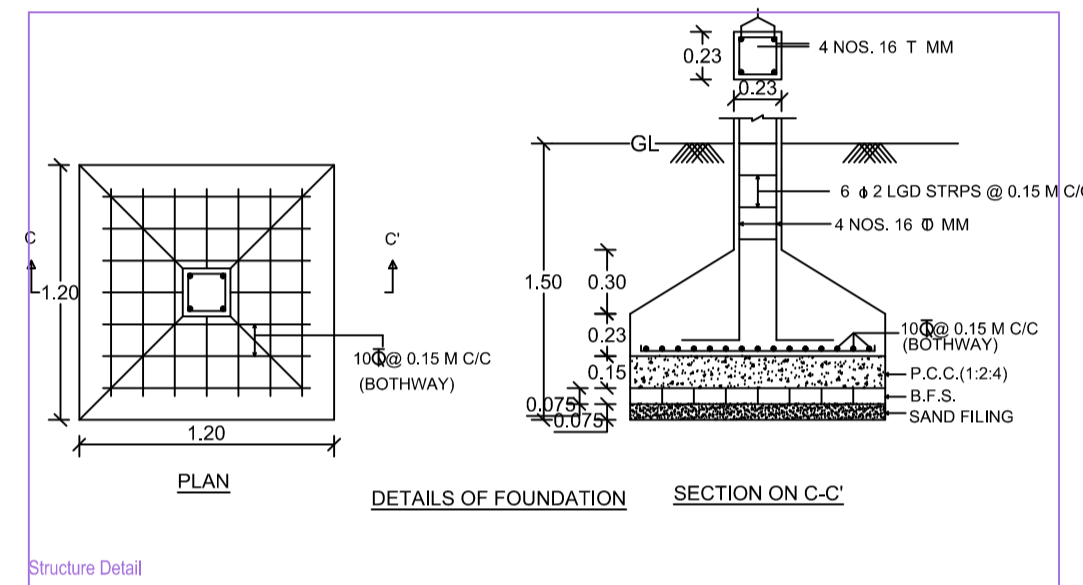
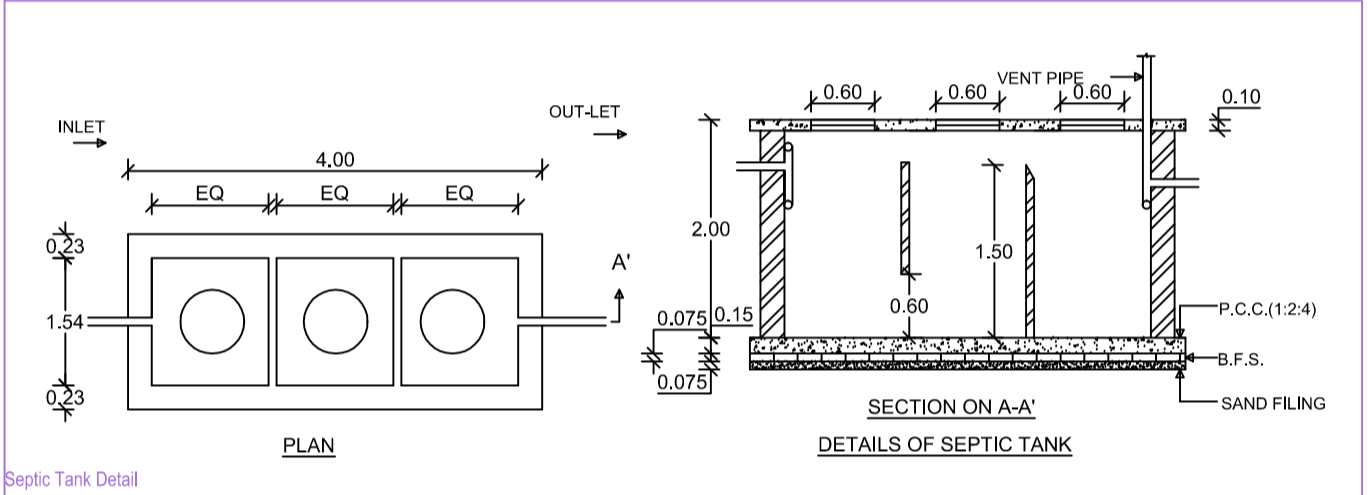
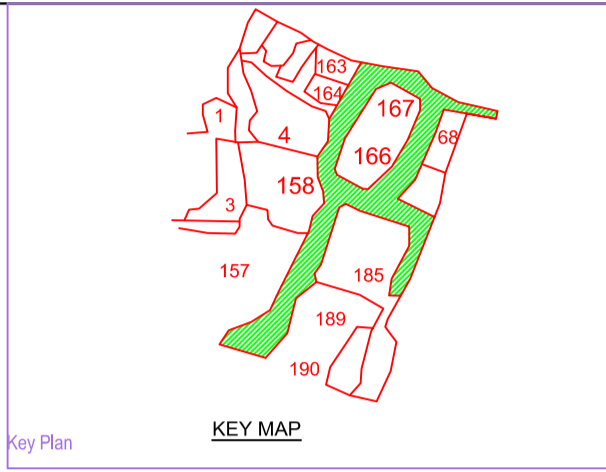
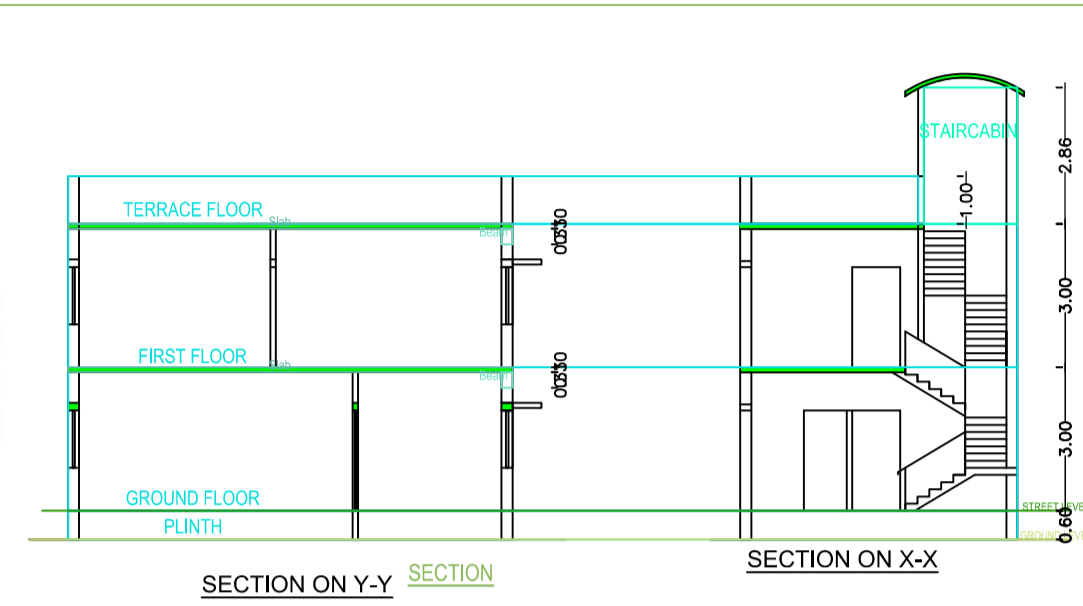
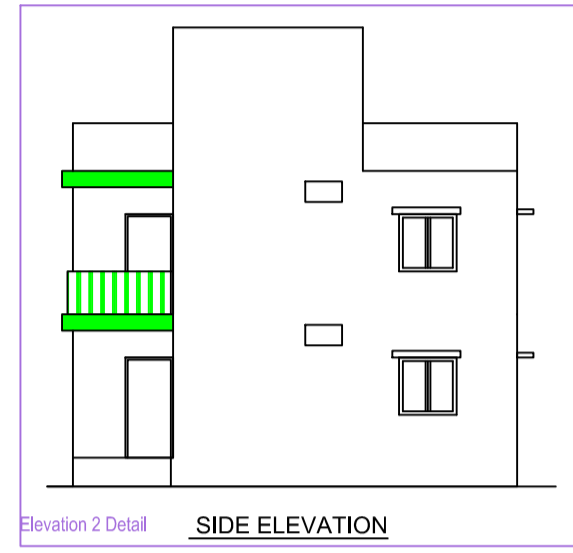
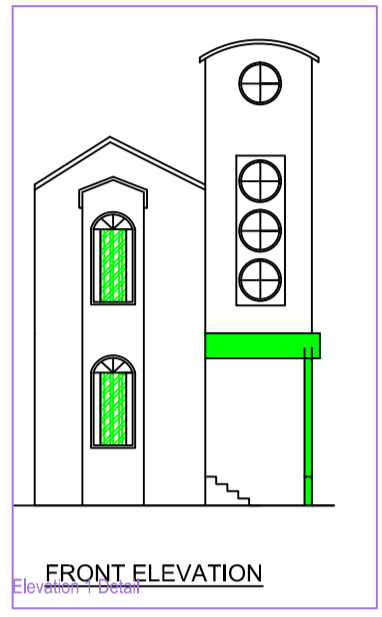

BRIEF SPECIFICATION
 STEEL = Fe-500 Grade TMT Steel Shall be used.
 FOUNDATION = CEMENT CONCRETE(1:1.5:3)M20 Grade.
 SUPERSTRUCTURE = BRICK WORK IN CM(1:6)
 FLOORING = 25 MM I.P.S./MARBLE/MOSAIC OVER 3" THICK P.C.C.
 D.P.C. = 25 MM TH. D.P.C. IN CEMENT CONCRETE(1:1.5:3)
 PLINTH = 0.15 M TH. R.C.C. BAND ALL ROUND IN M20 CONCRETE
 LINTELS = 0.15 M TH. R.C.C. LINTEL IN M20 GRADE CONCRETE
 WOOD WORK = ALL WOOD WORK IN HARD WOOD.
 PLASTERING = 12mm TH. CEMENT PLASTER BOTH SIDE IN CM (1:6)
 FINISHING = FIRST CLASS APPROVED QUALITY.
 ANTITERMITE = ANTI TERMITE TREATMENT IN FLOOR SHALL BE DONE.
 WATER PROOFING = ROOF AND WALL SHALL BE OF WATER RESISTANT.
 DRAINAGE = ADEQUATE DRAINAGE SHALL BE PROVIDED.
 IS CODES = BUILDING CODE OF INDIA SHALL BE FOLLOWED.
 CEMENT = 53 GRADE PRODUCED FROM 'A' GRADE PLANT.
 WALL = OUTER(0.23 THICK) & INNER(0.12 THICK)

SCHEDULE OF OPENINGS
 D = 1.00X2.10 D1 = 0.90X2.10 D2 = 0.75X2.10
 W = 1.20X1.20 W1 = 0.90X1.20 V = 0.60X0.45

SCHEDULE OF AREA

TITLE OF DRAWING
 SIGNATURE OF OWNER SIGNATURE OF ENGINEER

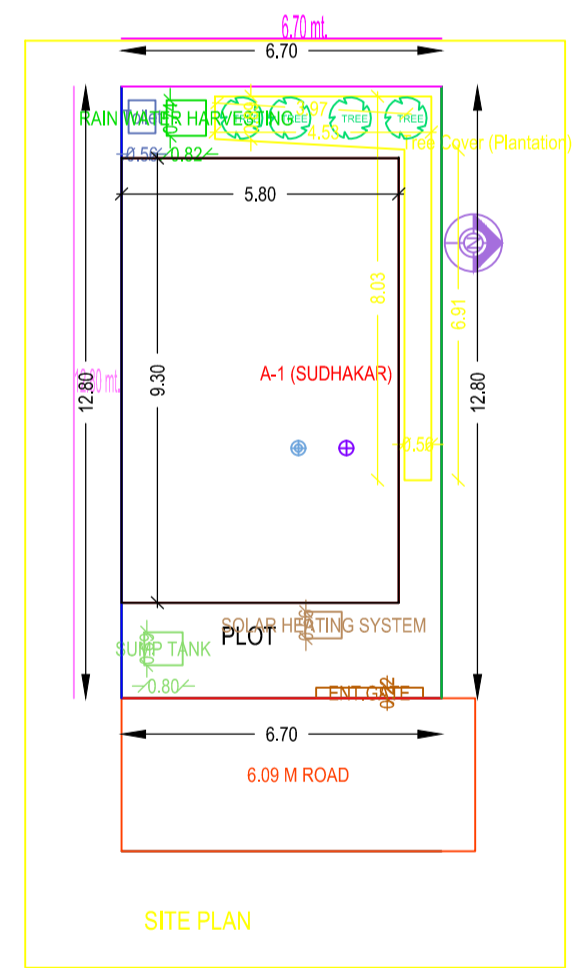
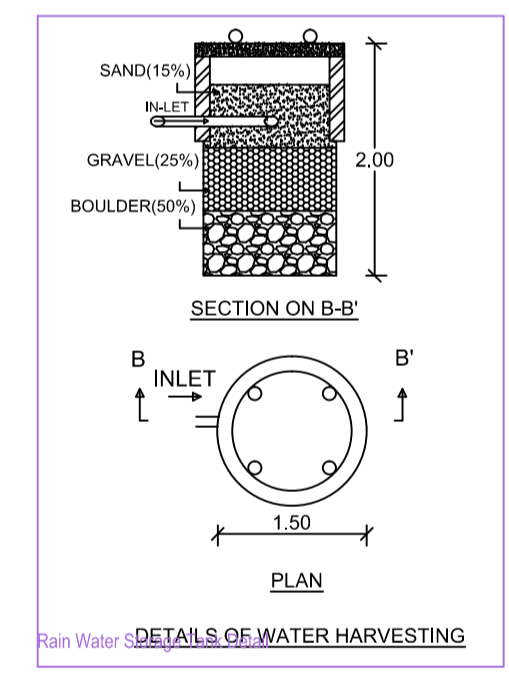
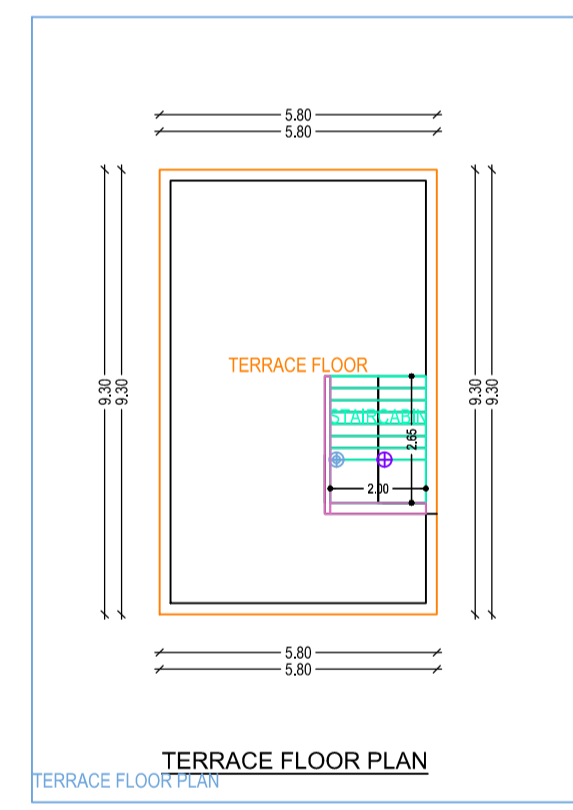
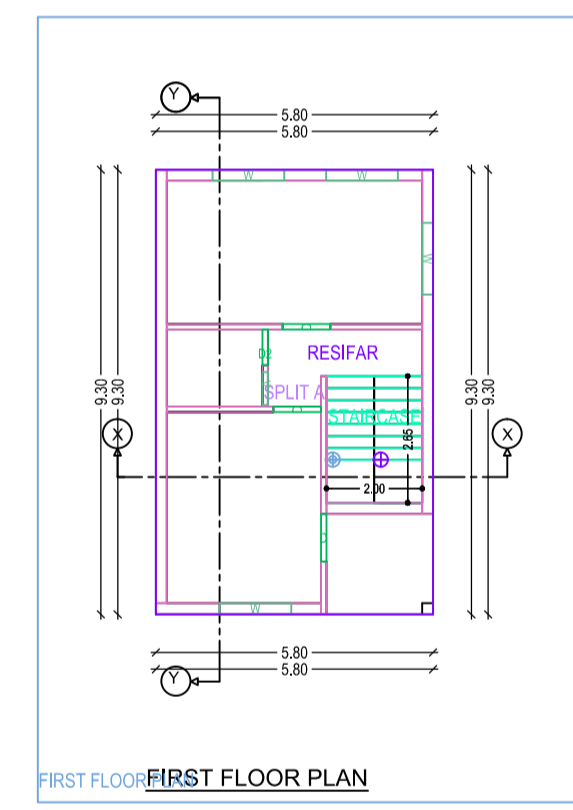
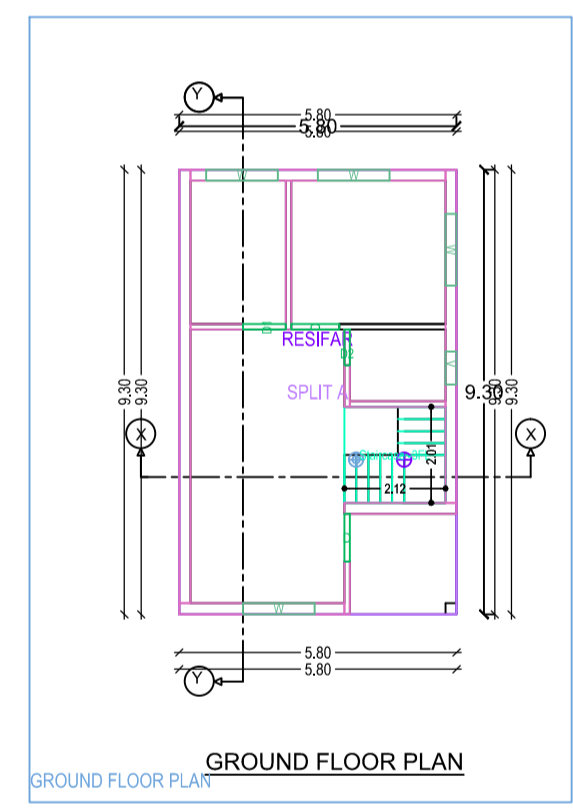

AREA STATEMENT CHAS MONOPOL CORPORATION		VERSION NO. 1.0.17			
PROJECT DETAIL:		VERSION DATE: 01/01/2019			
Project No. :-	Plot Use - Residential				
Region - JHARSUGUDA URBAN LOCAL BODIES	Plot Subtype - Bungalow Dwelling / Non Apartment				
Survey - SURKAR	Land Use Zone - M4				
Application Type - General Proposal	Abutting Road Width -				
Project Type - Building Permission	Plot No. -				
Name of Developer - New	Revenue Survey No./Survey No. -				
Location - Old Area	Thana No. -				
Sub Location - NA	Holding No. -				
Village/Mouza Name -	Khata No. -				
Ward No. -	North -				
Road/Street -	South -				
	East -				
	West -				
AREA DETAILS		SQ.MT.			
AREA OF PLOT (Minimum)	(A)	85.76			
Net Plot Area Gross Plot Area	(A)(Deductions)	85.76			
(Deductions from Gross Plot Area)					
Deductions for Balance Plot Area (from Gross Plot Area)					
COF Area		8.50			
Total		8.50			
Balance Plot Area (Net Plot Area - Processed/Unprocessed areas)	(A)(Deductions)	77.26			
Plot Area for Coverage (Net Plot Area)	(A)(Deductions)	85.76			
Plot Area for FAR (Net Plot Area - Road/Highway Area)	(A)(Deductions)	85.76			
+ Road/Highway Area					
Accessory/Use Area		0.58			
COVERAGE CHECK					
Proposed Coverage Area (82.50 %)		53.94			
Total Coverage Area (82.50 %)		53.94			
FAR CHECK					
Proposed Area of FAR		107.88			
Total Area of FAR		107.88			
BULKY TOP AREA CHECK					
Total Proposed Bulky Area		107.88			
ARCHT/ENGR/ SUPERVISOR (Sign)		OWNER			
DEVELOPMENT AUTHORITY		LOCAL BODY			
COLOR INDEX					
Plot Boundary					
Abutting Road					
Proposed Work (Coverage Area)					
Existing (to be retained)					
Existing (to be demolished)					
Color Index					
MARGIN DETAIL:					
Building Wing Name	Road Name	Front Margin	Rear Margin	Side Margin	Skid Margin
ACT (BUDHAKAR)	6.09 M ROAD	2.00	1.50	0.00	0.00
FAR & Tenement Details (Table 4c-1)					
Building	No. of Same Bldg.	Total Built Up Area (Sq.mt.)	Proposed FAR Area (Sq.mt.)	Total FAR Area (Sq.mt.)	Tenmt. (No.)
A (SUDHAKAR)	1	107.88	107.88	107.88	01
Grand Total	1	107.88	107.88	107.88	01

Building A (SUDHAKAR)					
Floor Name	Total Built Up Area (Sq.mt.)	Proposed FAR Area (Sq.mt.)	Total FAR Area (Sq.mt.)	Tenmt. (No.)	
Ground Floor	53.94	53.94	53.94	01	
First Floor	53.94	53.94	53.94	01	
Terrace Floor	0.00	0.00	0.00	00	
Total	107.88	107.88	107.88	01	
Total Number of Same Buildings	1				
Total	107.88	107.88	107.88	01	

SCHEDULE OF JOINERY:					
BUILDING NAME	NAME	LENGTH	HEIGHT	NOS	
A (SUDHAKAR)	W	0.75	2.10	02	
A (SUDHAKAR)	D	0.90	2.10	01	
A (SUDHAKAR)	D	1.00	2.10	05	
Total	-	-	-	08	

SCHEDULE OF JOINERY:					
BUILDING NAME	NAME	LENGTH	HEIGHT	NOS	
A (SUDHAKAR)	W	0.80	1.00	02	
A (SUDHAKAR)	W	1.50	1.20	08	
Total	-	-	-	10	

UHB/UA Table for Building A (SUDHAKAR)						
FLOOR	Name	UHB/UA Type	UHB/UA Area	Capex Area	No. of Rooms	No. of Tenement
FLOORING	SPLIT A	FLAT	107.88	53.07	5	1
WALL	-	-	107.88	53.07	9	1