

FRONT ELEVATION

SIDE ELEVATION

SECTION AT-A-A

SECTION AT-B-B

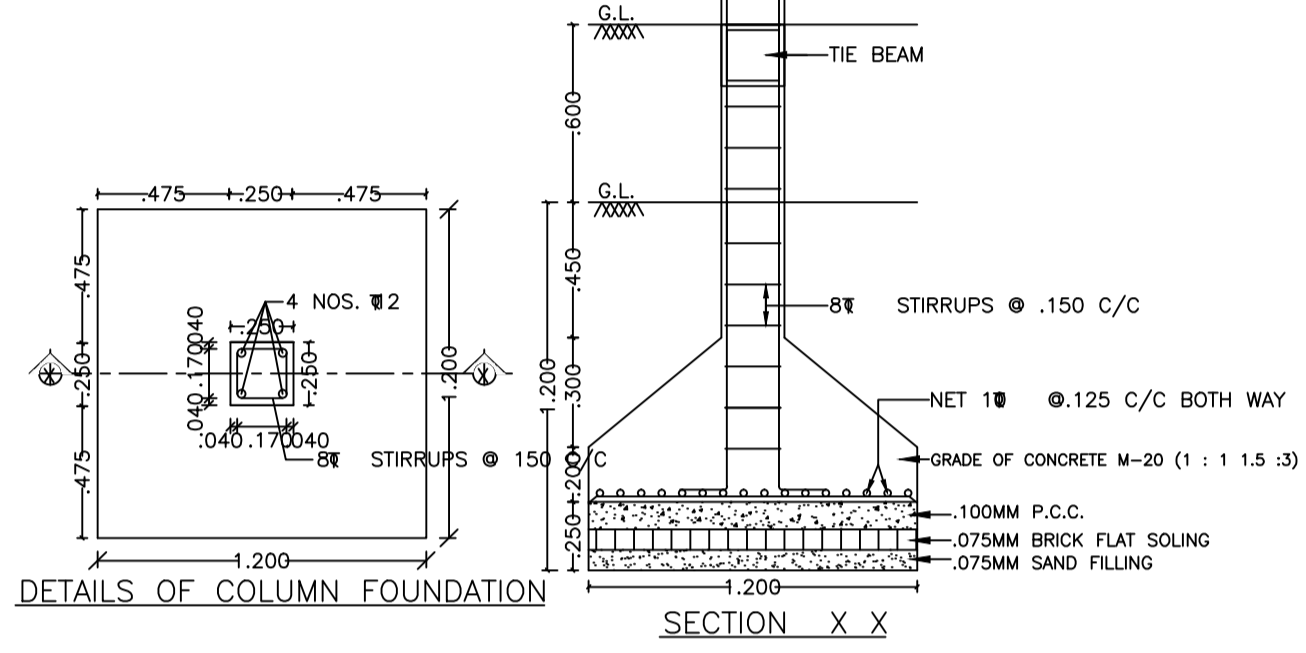

DETAILS OF COLUMN FOUNDATION

SECTION X X

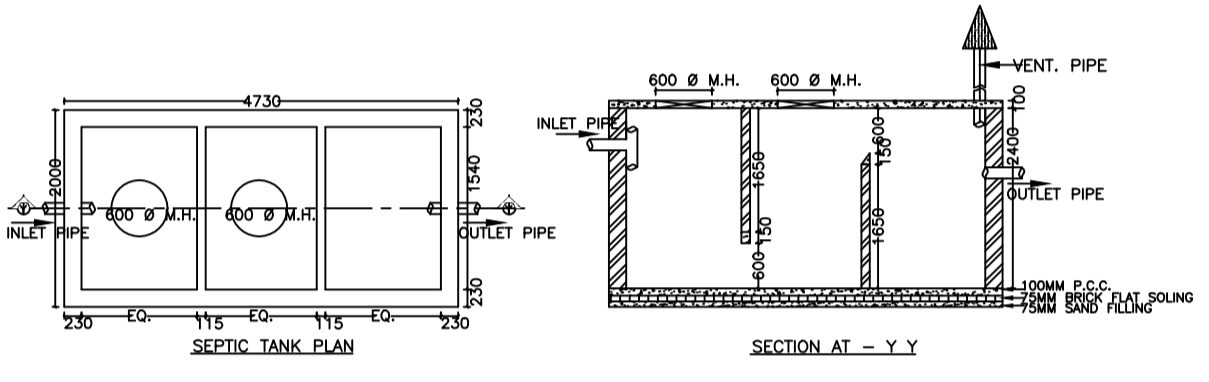

SEPTIC TANK PLAN

SECTION AT - Y Y

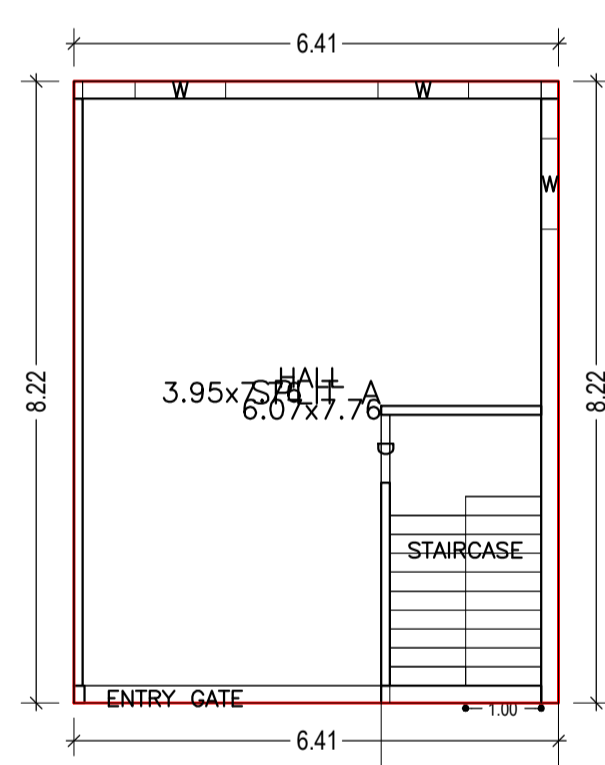

GROUND FLOOR PLAN (Proposed) (SCALE 1:100)

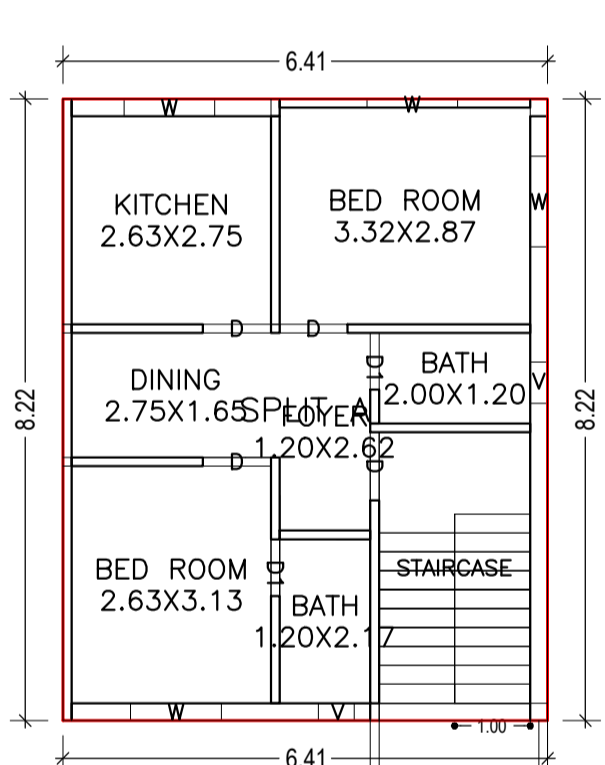

FIRST FLOOR PLAN (Proposed) (SCALE 1:100)

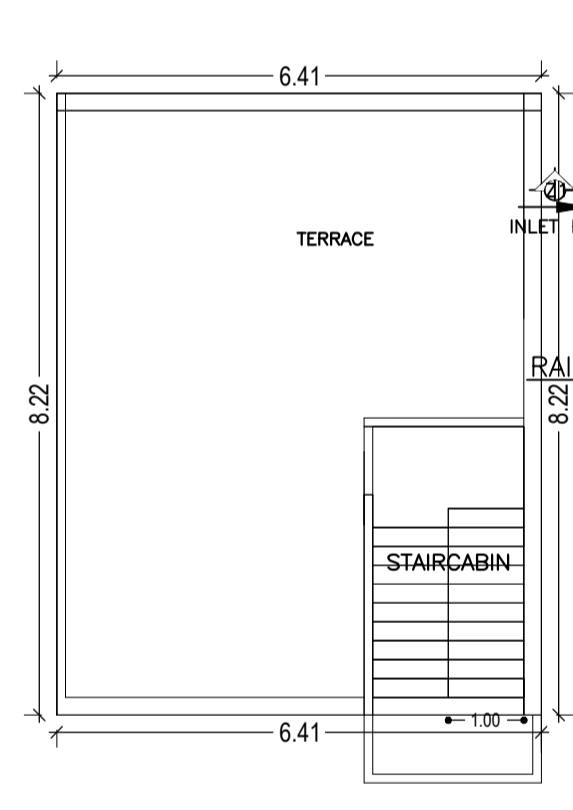

TERRACE FLOOR PLAN (SCALE 1:100)

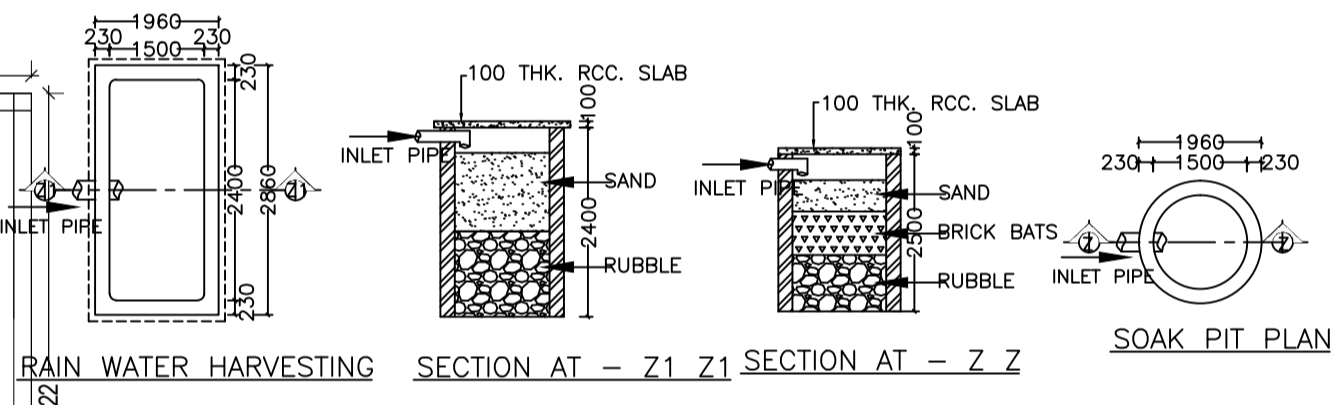

RAIN WATER HARVESTING

SECTION AT - Z1 Z1

SECTION AT - Z Z

SOAK PIT PLAN

UnitBUA Table for Building :A (MANOJ)

FLOOR	Name	UnitBUA Type	UnitBUA Area	Carpet Area	No. of Rooms	No. of Tenement
GROUND FLOOR PLAN	SPLIT A	FLAT	105.41	93.39	1	1
FIRST FLOOR PLAN	SPLIT A	FLAT	0.00	0.00	7	0
Total:	-	-	105.41	93.39	8	1

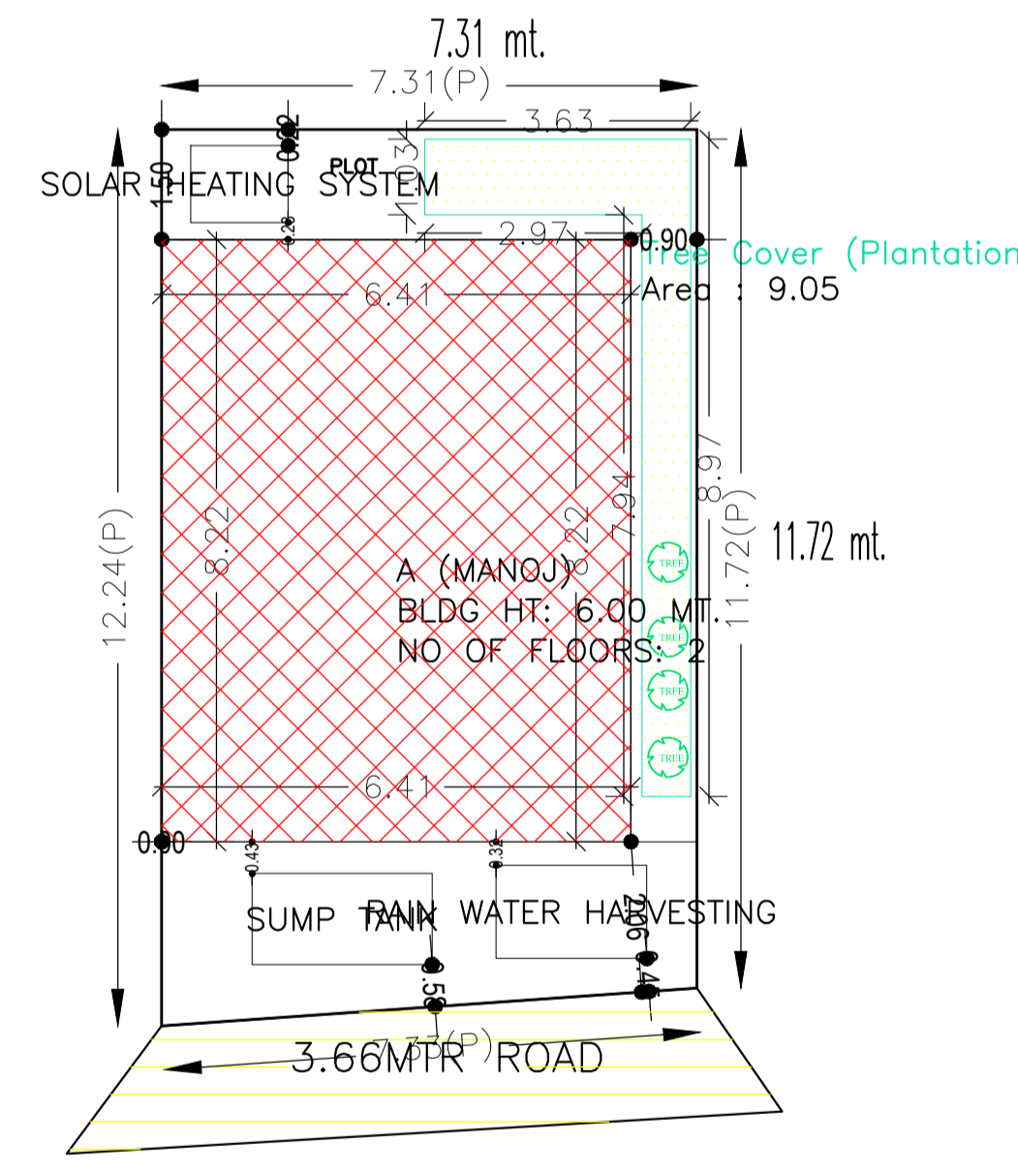

SITE PLAN

Proposal Basic Information

Proposal File No.	CMC/BP/0172/W17/2019
Owner Name	MANOJ PRASAD BARNWAL
Khata No	126
Plot No	260,262
Village Name	Bhawanipur
Use	Residential
SubUse	Bungalow/ Dwelling / Non Apartment

AREA STATEMENT CHAS MUNICIPAL CORPORATION		VERSION NO. : 1.0.39
PROJECT DETAIL:		VERSION DATE: 29/04/2019
Region: JHARKHAND URBAN LOCAL BODIES	Plot Use: Residential	
District: BOKARO	Plot SubUse: Bungalow/ Dwelling / Non Apartment	
Authority: CHAS MUNICIPAL CORPORATION	PlotNearby/ReligiousStructure: NA	
Inward No: CMC/BP/0172/W17/2019	Plot/SubPlot No: 260.262	
Application Type: General Proposal	North: Road Width - 3.66 MTR WIDE ROAD	
Project Type: Building Permission	South: CTS No. - RAMRUDRA HIGH SCHOOL BOUNDARY	
Nature of Development: New	East: CTS No. - BULAKI BARNWAL	
Location of Development Area: Old Area	West: CTS No. - JAGDISH BARNWAL	
AREA DETAILS:		SQ.MT.
AREA OF PLOT (Minimum)	(A)	87.57
NET AREA OF PLOT(Gross Plot Area - Deduction from Gross Plot area)	(A-Deductions)	87.57
Deduction for Balance Plot Area(from Gross Plot Area)		
Common Plot		9.05
Total		9.05
BALANCE AREA OF PLOT(Net Plot Area - Recreational/Amenity space)	(A-Deductions)	78.53
PLOT AREA FOR COVERAGE(Net Plot Area)	(A-Deductions)	87.57
Plot Area for FAR (Net Plot Area + RoadWidening Area)	(A-Deductions)	87.57
COVERAGE CHECK		
Permissible Coverage area (70.00 %)		61.30
Proposed Coverage Area (60.19 %)		52.71
Total Prop. Coverage Area (60.19 %)		52.71
Balance coverage area (9.81 %)		8.59
FAR CHECK		
Perm. FAR Area (1.50)		131.35
Total Perm. FAR area		131.35
Residential FAR		105.41
Proposed FAR Area		105.41
Total Proposed FAR Area		105.41
Consumed FAR (Factor)		1.20
Balance FAR Area		25.94
BUILT UP AREA CHECK		
Total Proposed BuiltUp Area		105.42
ARCHITECT (Regd)		RAGHUNATH CHOUDHARY
ENGINEER (Regd)		
SUPERVISOR (Regd)		
OWNER (Regd)		MANOJ PRASAD BARNWAL
DEVELOPMENT AUTHORITY		LOCAL BODY

Building :A (MANOJ)

Floor Name	Total Built Up Area (Sq.mt.)	Proposed FAR Area (Sq.mt.) Resi.	Total FAR Area (Sq.mt.)	Total Consumed Additional FAR Area (Sq.mt.)	Trmt (No.)
Ground Floor	52.71	52.71	52.71	52.71	01
First Floor	52.71	52.71	52.71	52.71	00
Terrace Floor	0.00	0.00	0.00	0.00	00
Total :	105.42	105.42	105.42	105.42	01
Total Number of Same Buildings :	1				
Total :	105.42	105.42	105.42	105.42	01

SCHEDULE OF DOOR:

BUILDING NAME	NAME	LENGTH	HEIGHT	NOS
A (MANOJ)	D1	0.75	2.10	02
A (MANOJ)	D	0.90	2.10	05
A (MANOJ)	ENTRY GATE	3.93	2.10	01

SCHEDULE OF WINDOW/VENTILATION:

BUILDING NAME	NAME	LENGTH	HEIGHT	NOS
A (MANOJ)	V	0.47	1.20	01
A (MANOJ)	V	0.55	1.20	01
A (MANOJ)	W	1.20	1.20	07

Building USE/SUBUSE Details

Building Name	Building Use	Building SubUse	Building Structure
A (MANOJ)	Residential	Bungalow/ Dwelling / Non Apartment	Non-Highrise

COLOR INDEX

PLOT BOUNDARY	Black
ABUTTING ROAD	Green
PROPOSED CONSTRUCTION	Red
COMMON PLOT	Yellow
ROAD WIDENING AREA	Blue
EXISTING (To be retained)	Orange
EXISTING (To be demolished)	Light Blue

Buildingwise Floor FAR Details

FAR & Tenement Details (Table 4c-1)

Building	No. of Same Bldg	Total Built Up Area (Sq.mt.)	Proposed FAR Area (Sq.mt.) Resi.	Total FAR Area (Sq.mt.)	Total Consumed Additional FAR Area (Sq.mt.)	Trmt (No.)
A (MANOJ)	1	105.42	105.42	105.42	105.42	01
Grand Total :	1	105.42	105.42	105.42	105.42	01

Floor Name	Building Name A (MANOJ)		Total	
	Proposed Built Up Area (Sq.mt.)	Proposed FAR Area (Sq.mt.)	Total Proposed Built Up Area (Sq.mt.)	Total FAR Area (Sq.mt.)
Ground Floor	52.71	52.71	52.71	52.71
First Floor	52.71	52.71	52.71	52.71
Terrace Floor	0.00	0.00	0.00	0.00
Total :	105.42	105.42	105.42	105.42

LTP NAME AND SIGNATURE	STRUCTURAL ENG'S NAME AND SIGNATURE	BUILDER NAME AND SIGNATURE	DIGITAL SIGNATURE
RAGHUNATH CHOUDHARY CMC/DFTM/0004/2018			