

FRONT ELEVATION

SECTION AT-A-A

SECTION AT-B-B

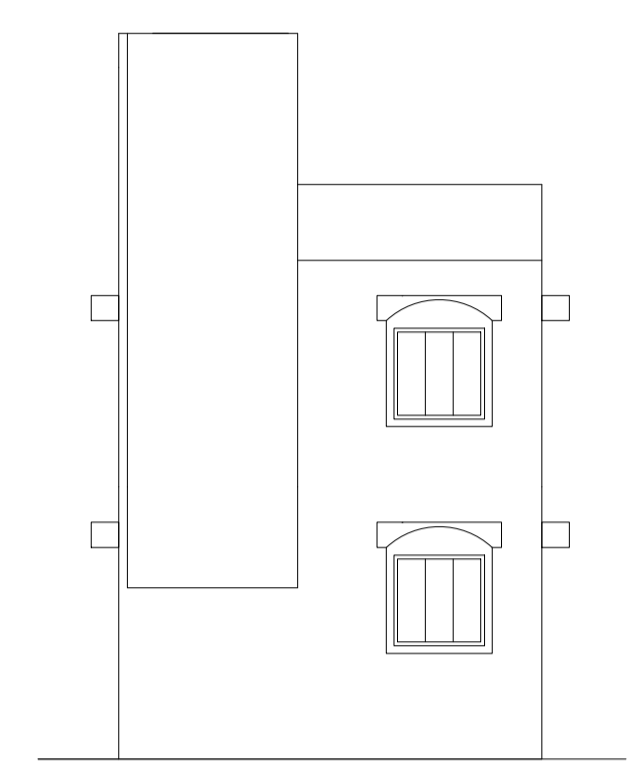

SIDE ELEVATION

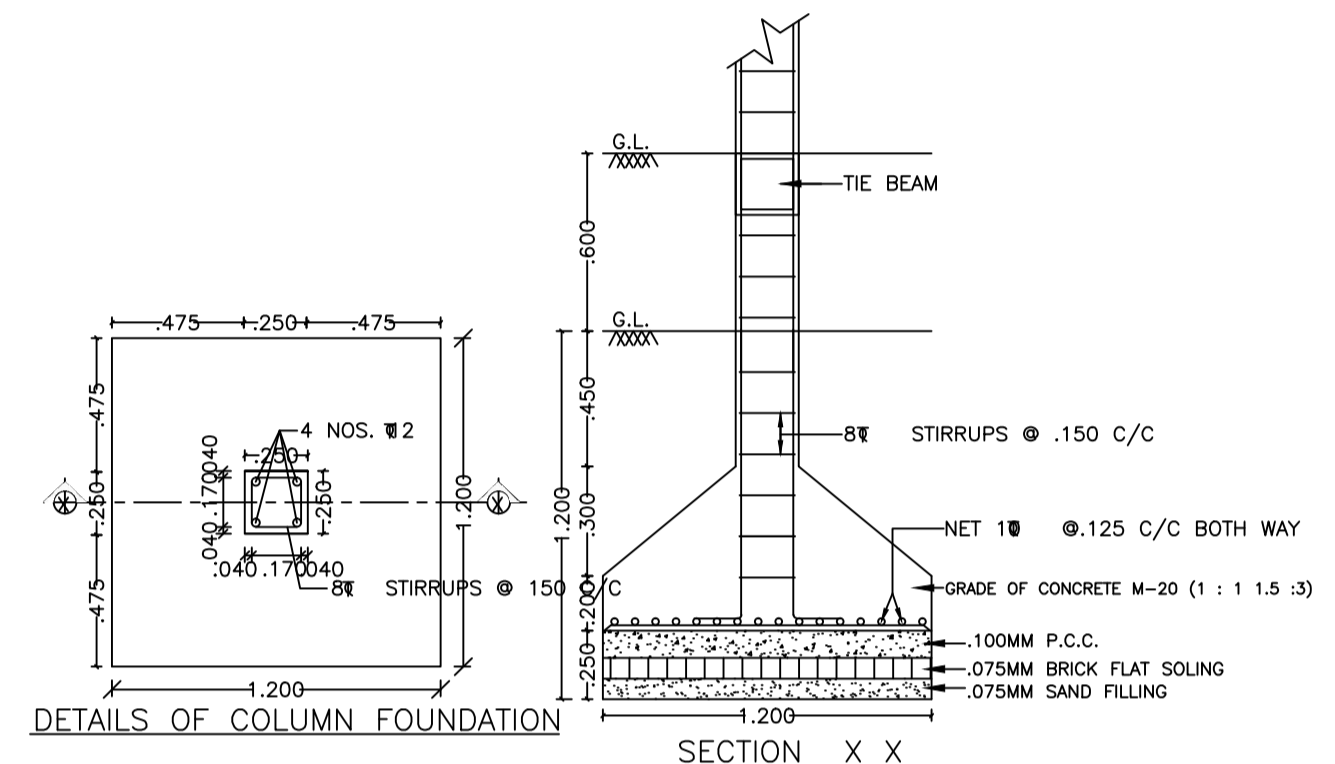

DETAILS OF COLUMN FOUNDATION

SECTION X-X

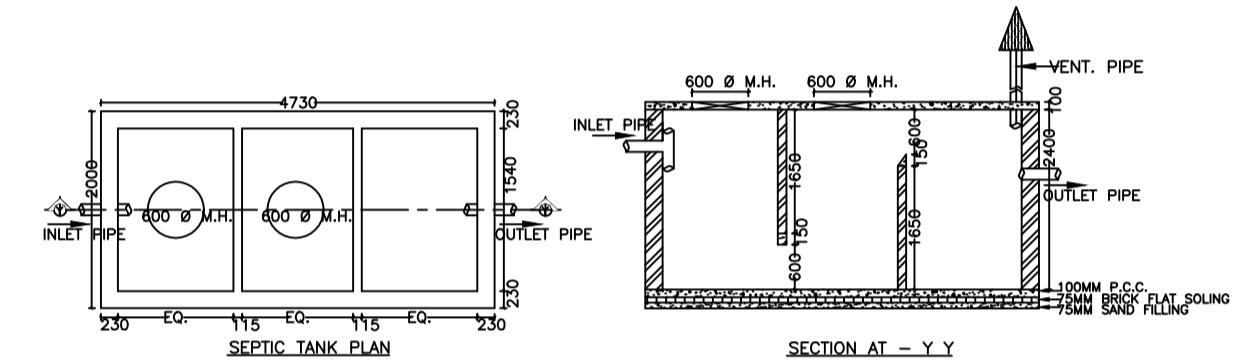

SEPTIC TANK PLAN

SECTION AT-Y-Y

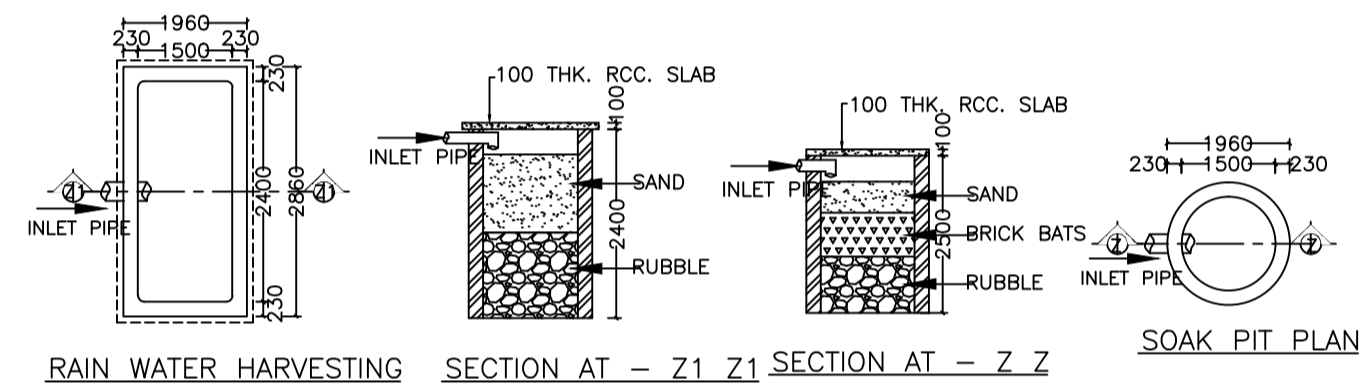

RAIN WATER HARVESTING

SECTION AT-Z1-Z1

SECTION AT-Z-Z

SOAK PIT PLAN

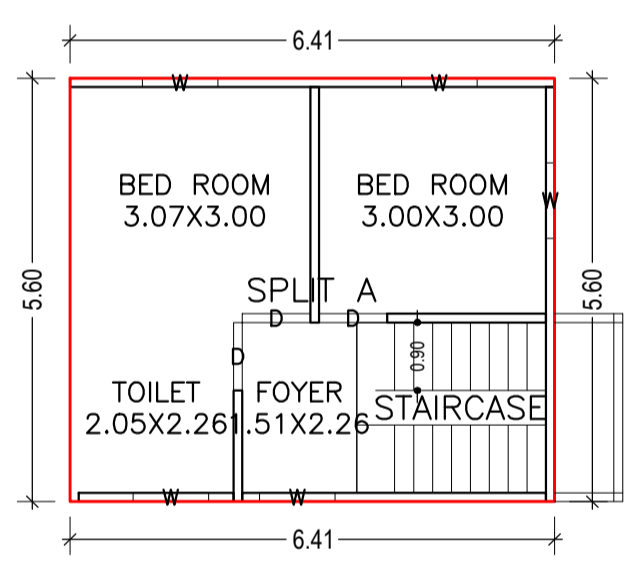

FIRST FLOOR PLAN (Proposed) (SCALE 1:100)

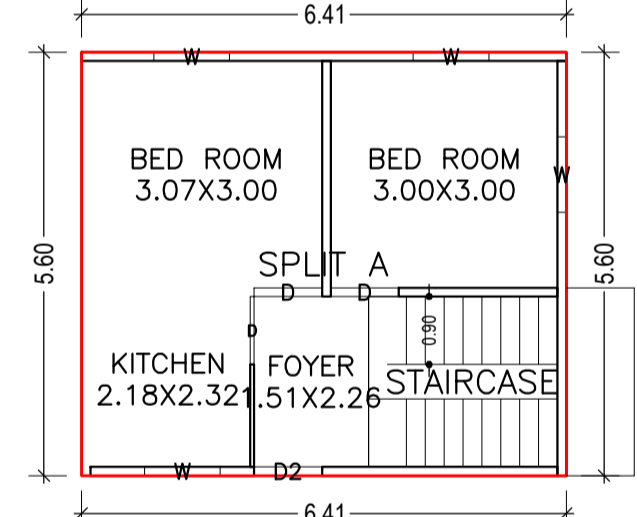

GROUND FLOOR PLAN (Proposed) (SCALE 1:100)

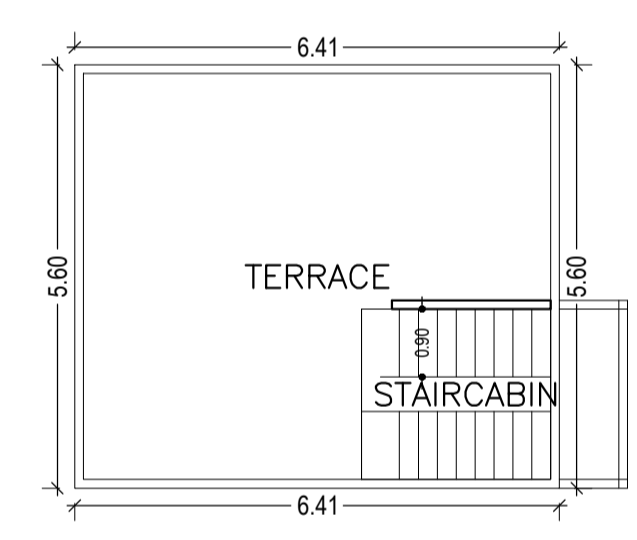

TERRACE FLOOR PLAN (SCALE 1:100)

COLOR INDEX

- PLOT BOUNDARY
- ABUTTING ROAD
- PROPOSED CONSTRUCTION
- COMMON PLOT
- ROAD WIDENING AREA
- EXISTING (To be retained)
- EXISTING (To be demolished)

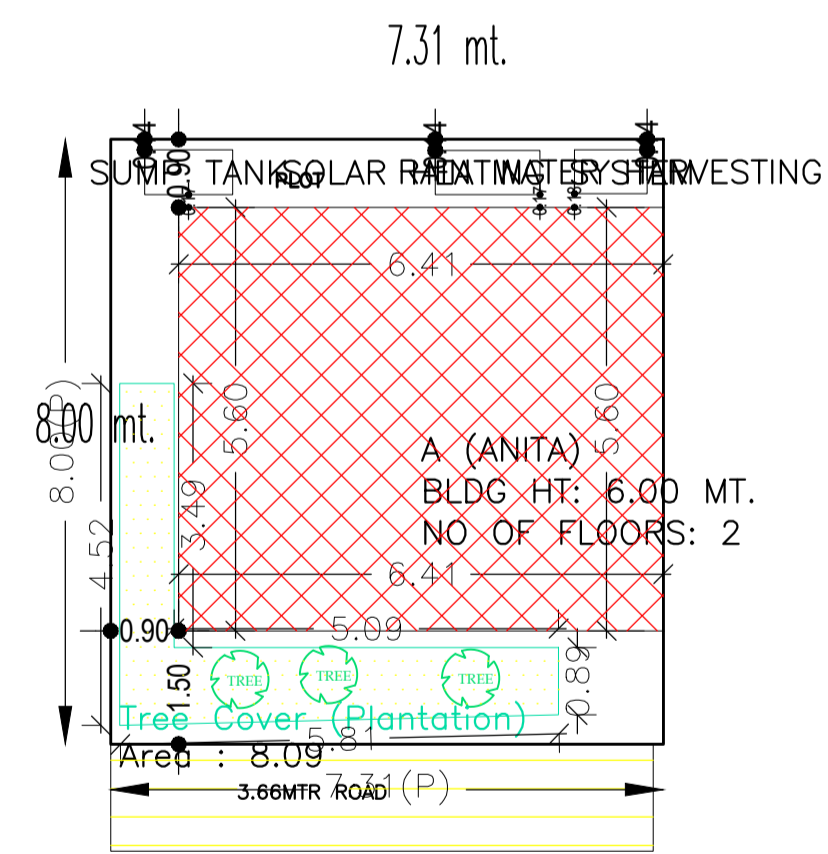

SITE PLAN

Proposal Basic Information

Proposal File No.	CMC/BP/0154/W17/2019
Owner Name	ANITA DEVI
Khata No	50
Plot No	37
Village Name	Bhawanipur
Use	Residential
SubUse	Bungalow/ Dwelling / Non Apartment

AREA STATEMENT CHAS MUNICIPAL CORPORATION	VERSION NO: 1.0.37	VERSION DATE: 29/04/2019
PROJECT DETAIL:	Plot Use: Residential	
Region: JHARKHAND URBAN LOCAL BODIES	Plot SubUse: Bungalow/ Dwelling / Non Apartment	
District: BOKARO	PlotNearbyReligiousStructure: NA	
Authority: CHAS MUNICIPAL CORPORATION	North: CTS No. - NUJ	
Inward No: CMC/BP/0154/W17/2019	PlotSubPlot No: 37	
Application Type: General Proposal	East: Road Width - 3.66 MTR WIDE ROAD	
Project Type: Building Permission	West: CTS No. - SHAKTI PAD MODAK	
Nature of Development: New		
Location of Development Area: Old Area		
AREA DETAILS:		SQ. MT.
AREA OF PLOT (Minimum)	(A)	58.48
NET AREA OF PLOT (Gross Plot Area - Deduction from Gross Plot area)	(A-Deductions)	58.48
Deduction for Balance Plot Area (from Gross Plot Area)		
Common Plot		8.09
Total		8.09
BALANCE AREA OF PLOT (Net Plot Area - Recreational/Amenity space)	(A-Deductions)	50.39
PLOT AREA FOR COVERAGE (Net Plot Area)	(A-Deductions)	58.48
Plot Area for FAR (Net Plot Area + Road Widening Area)	(A-Deductions)	58.48
COVERAGE CHECK		
Permissible Coverage area (70.00 %)		40.94
Proposed Coverage Area (61.39 %)		35.90
Total Prop. Coverage Area (61.39 %)		35.90
Balance coverage area (8.62 %)		5.04
FAR CHECK		
Perm. FAR Area (1.50)		87.72
Total Perm. FAR area		87.72
Residential FAR		71.79
Proposed FAR Area		71.79
Total Proposed FAR Area		71.79
Consumed FAR (Factor)		1.23
Balance FAR Area		15.93
BUILT UP AREA CHECK		
Total Proposed BuiltUp Area		71.80
ARCHITECT (Regd)		RAGHUNATH CHOUDHARY
ENGINEER (Regd)		
SUPERVISOR (Regd)		
OWNER (Regd)		ANITA DEVI
DEVELOPMENT AUTHORITY		LOCAL BODY

SCHEDULE OF DOOR:

BUILDING NAME	NAME	LENGTH	HEIGHT	NOS
A (ANITA)	D	0.90	2.10	06
A (ANITA)	D2	0.90	2.10	01

SCHEDULE OF WINDOW/VENTILATION:

BUILDING NAME	NAME	LENGTH	HEIGHT	NOS
A (ANITA)	W	1.00	1.20	09

UnitBUA Table for Building :A (ANITA)

FLOOR	Name	UnitBUA Type	UnitBUA Area	Carpet Area	No. of Rooms	No. of Tenement
GROUND FLOOR PLAN	SPLIT A	FLAT	71.79	66.32	4	1
FIRST FLOOR PLAN	SPLIT A	FLAT	0.00	0.00	4	0
Total:	-	-	71.79	66.32	8	1

Building :A (ANITA)

Floor Name	Total Built Up Area (Sq.mt.)	Proposed FAR Area (Sq.mt.) Resi.	Total FAR Area (Sq.mt.)	Total Consumed Additional FAR Area (Sq.mt.)	Tnmt (No.)
Ground Floor	35.90	35.90	35.90	35.90	01
First Floor	35.90	35.90	35.90	35.90	00
Terrace Floor	0.00	0.00	0.00	0.00	00
Total :	71.80	71.80	71.80	71.80	01
Total Number of Same Buildings :	1				
Total :	71.80	71.80	71.80	71.80	01

Buildingwise Floor FAR Details

Building USE/SUBUSE Details

Building Name	Building Use	Building SubUse	Building Structure
A (ANITA)	Residential	Bungalow/ Dwelling / Non Apartment	Non-Highrise

Floor Name	Building Name A (ANITA)		Total	
	Proposed Built Up Area (Sq.mt.)	Proposed FAR Area (Sq.mt.)	Total Proposed Built Up Area (Sq.mt.)	Total FAR Area (Sq.mt.)
Ground Floor	35.90	35.90	35.90	35.90
First Floor	35.90	35.90	35.90	35.90
Terrace Floor	0.00	0.00	0.00	0.00
Total :	71.80	71.80	71.80	71.80

FAR & Tenement Details (Table 4c-1)

Building	No. of Same Bldg	Total Built Up Area (Sq.mt.)	Proposed FAR Area (Sq.mt.) Resi.	Total FAR Area (Sq.mt.)	Total Consumed Additional FAR Area (Sq.mt.)	Tnmt (No.)
A (ANITA)	1	71.80	71.80	71.80	71.80	01
Grand Total :	1	71.80	71.80	71.80	71.80	01

LTP NAME AND SIGNATURE	STRUCTURAL ENG'S NAME AND SIGNATURE	BUILDER NAME AND SIGNATURE	DIGITAL SIGNATURE
RAGHUNATH CHOUDHARY CMC/DFTM/0004/2018			