

Project Title : POONAM PRASAD

**BRIEF SPECIFICATION**  
 STEEL = Fe-500 Grade TMT Steel Shall be used.  
 FOUNDATION = CEMENT CONCRETE(1:1.5:3)M20 Grade.  
 SUPERSTRUCTURE = BRICK WORK IN CM(1:6)  
 FLOORING = 25 MM I.P.S./MARBLE/MOSAIC COVER 3" THICK P.C.C.  
 D.P.C. = 25 MM th, D.P.C. IN CEMENT CONCRETE(1:1.5:3)  
 PLINTH = 0.15 M TH. R.C.C. BAND ALL ROUND IN M20 CONCRETE  
 LINTELS = 0.15 M TH. R.C.C. LINTEL IN M20 GRADE CONCRETE  
 WOOD WORK = ALL WOOD WORK IN HARD WOOD.  
 PLASTERING = 12mm TH. CEMENT PLASTER BOTH SIDE IN CM (1:6)  
 FINISHING = FIRST CLASS APPROVED QUALITY.  
 ANTITERMITE = ANTI TERMITE TREATMENT IN FLOOR SHALL BE DONE.  
 WATER PROOFING = ROOF AND WALL SHALL BE OF WATER RESISTANT.  
 DRAINAGE = ADEQUATE DRAINAGE SHALL BE PROVIDED.  
 IS CODES = BUILDING CODE OF INDIA SHALL BE FOLLOWED.  
 CEMENT = 53 GRADE PRODUCED FROM 'A' GRADE PLANT.  
 WALL = OUTER(0.23 THICK) & INNER(0.12 THICK)

**SCHEDULE OF OPENINGS**  
 D2 =0.75X2.10      D1 =0.90X2.10      D =1.00X2.10  
 V =0.60X0.45      W1 =0.90X1.20      W =1.20X1.20

**SCHEDULE OF AREA**

**TITLE OF DRAWING**

SIGNATURE OF ENGINEER      SIGNATURE OF OWNER

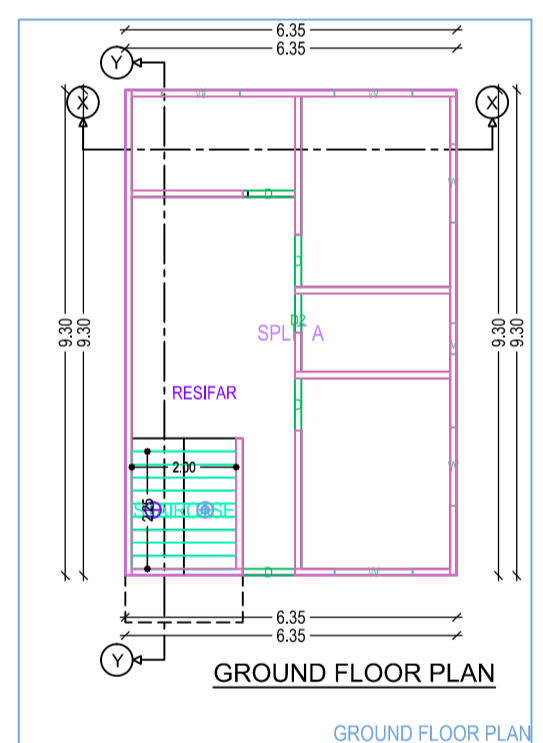
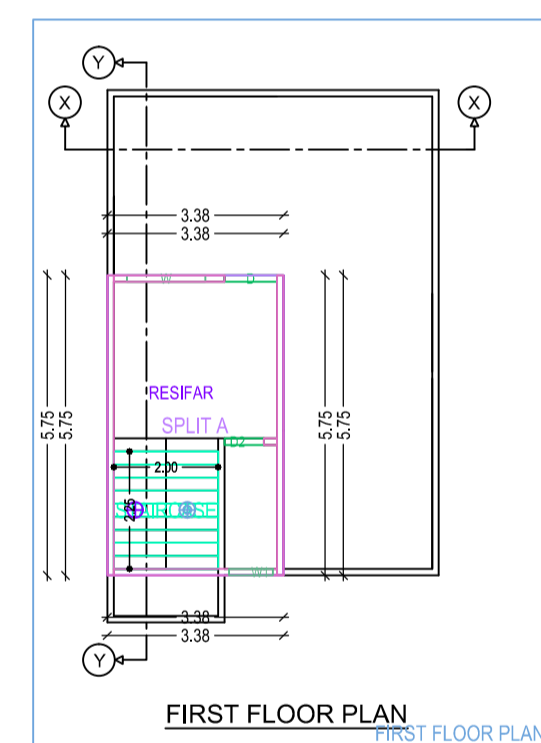
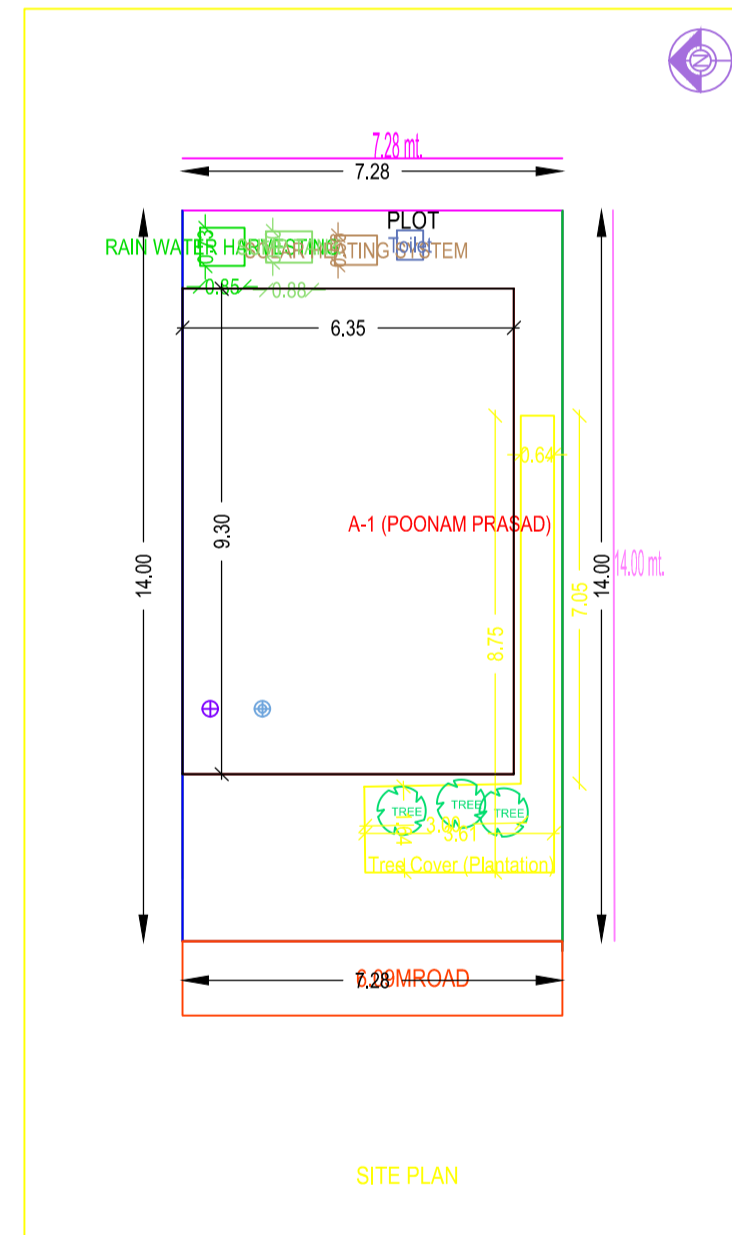
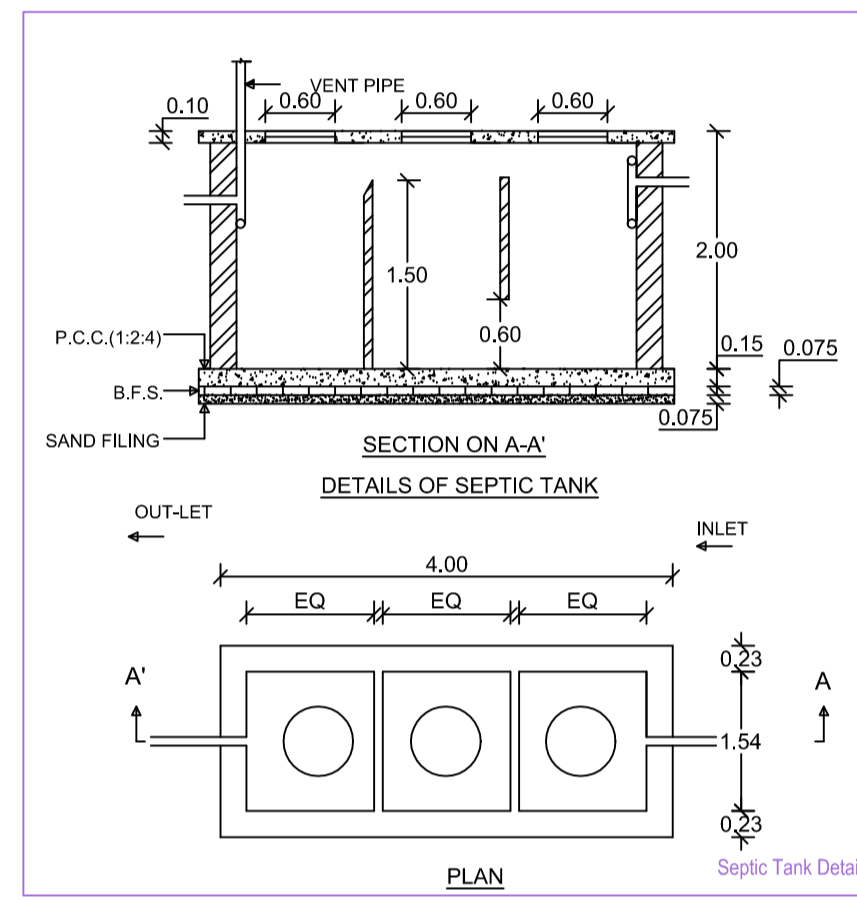
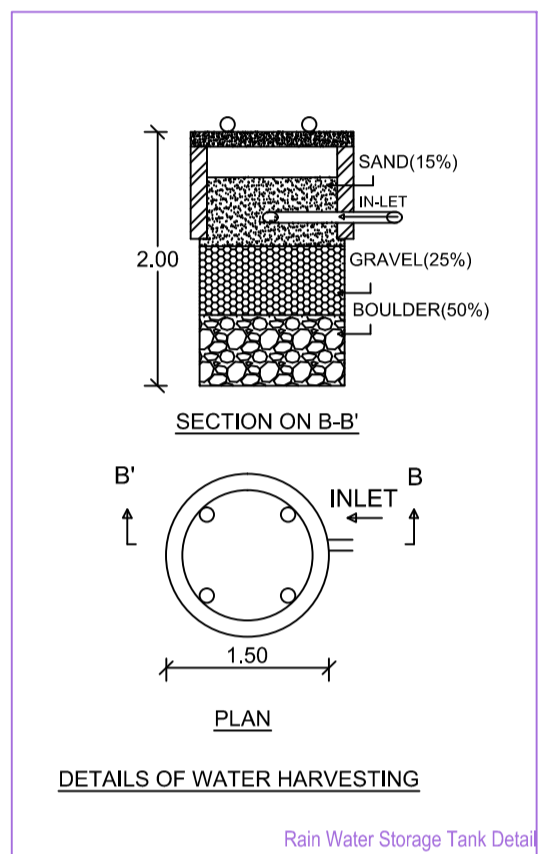
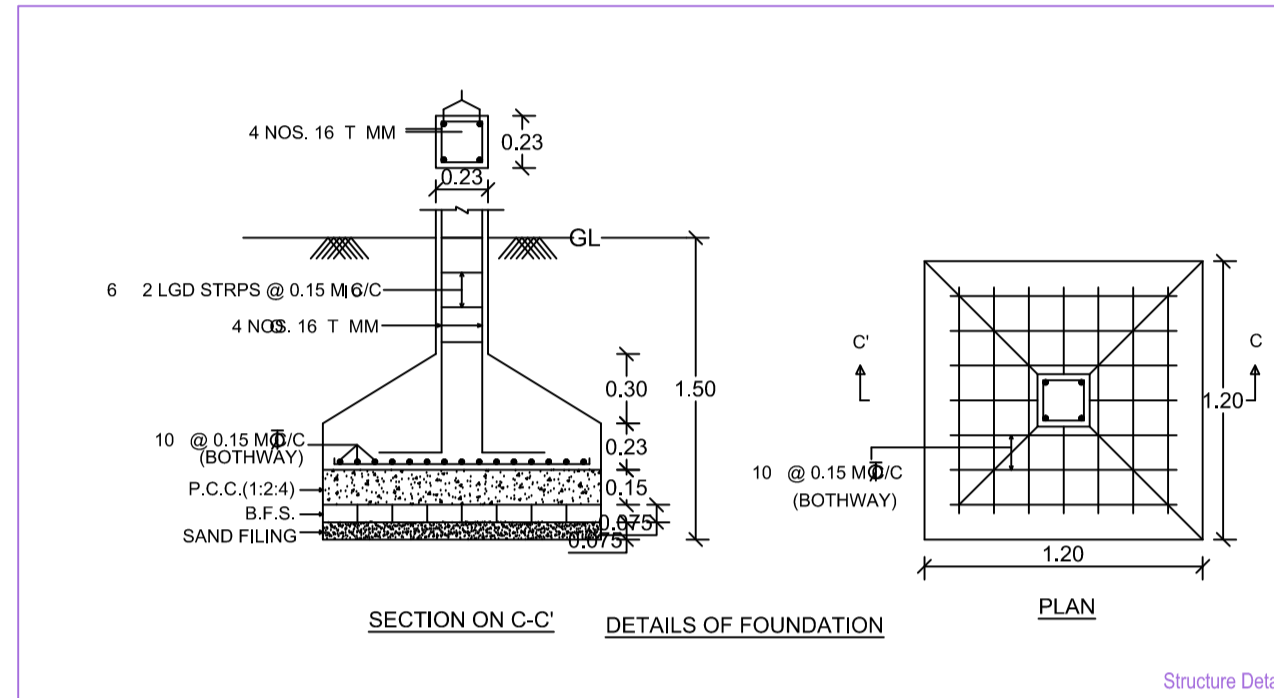
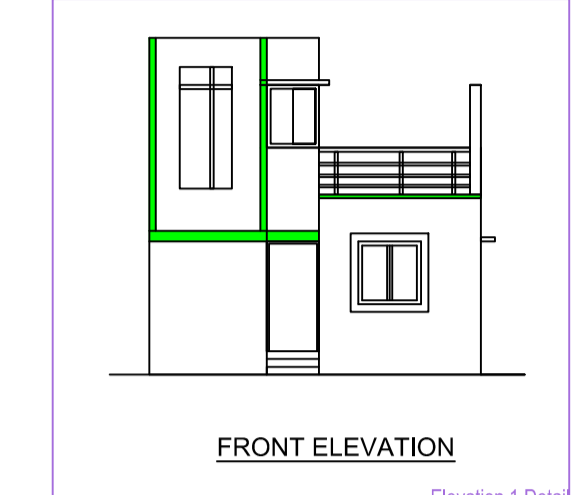
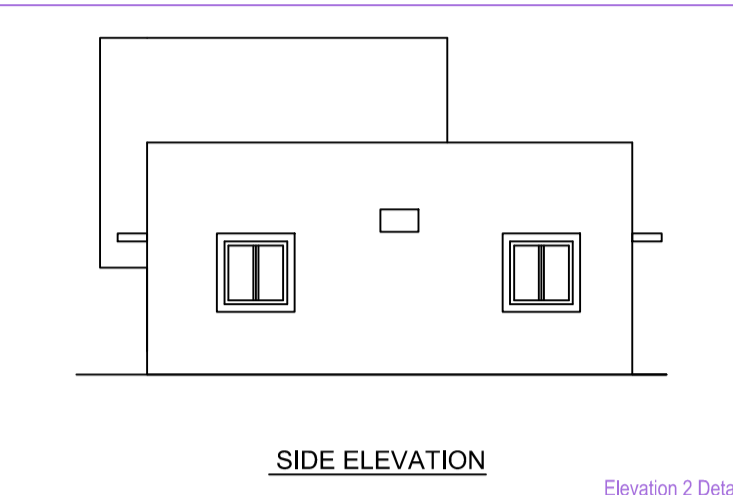
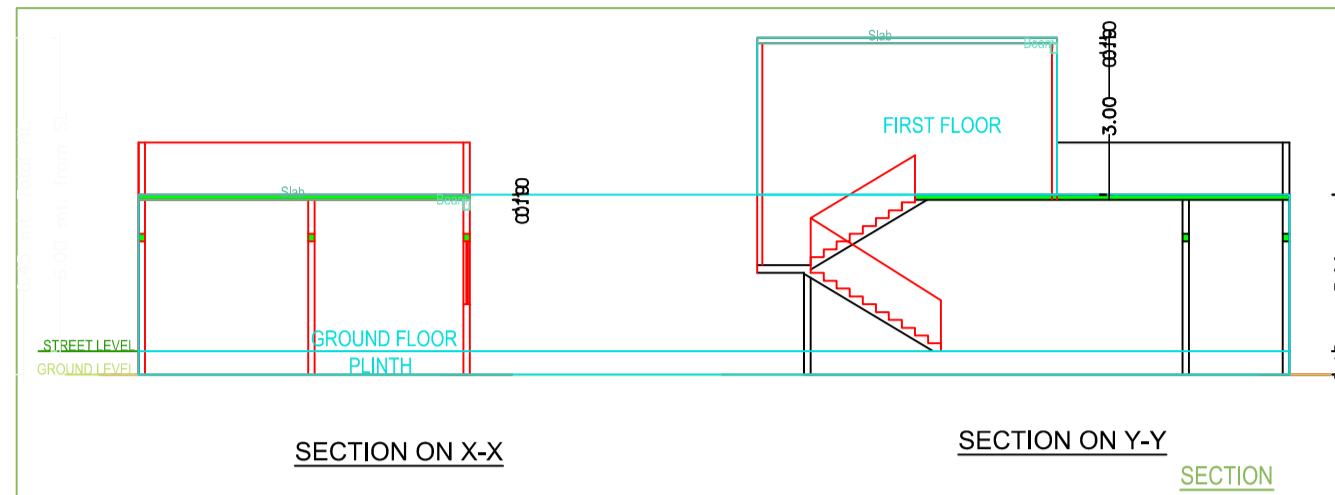

AREA STATEMENT CHAS MUNICIPAL CORPORATION	VERSION NO. 1.0/16
PROJECT DETAIL	VERSION DATE: 01/01/2019
Grant No. :-	Plot Use Residential
Region :-HARRAHAND URBAN LOCAL BODIES	Plot SubUse :-Bungalow/Dwelling /Non Apartment
District :-KORNO	Land Use Zone :-NA
Application Type :-General Proposal	Abutting Road Width :-
Project Type :-Building Permission	Plot No. :-
Nature of Development :-New	Revenue Survey No/Survey No :-
Location :-CG Area	Thana No. :-
Sub Location :-NA	Holding No. :-
Original/Map Name :-	Khata No. :-
Ward No. :-	North :-
Road/Street :-	South :-
	East :-
	West :-

<b>AREA DETAILS:</b>		AREA	SQ.MT.
AREA OF PLOT (Minimum)	(A)		101.92
Net Plot Area (Gross Plt Area - Deductions from Gross Plt Area)	(A-Deductions)		101.92
Deductions by Balance Plt Area (from Gross Plt Area)			
COIP Area			10.56
Total			10.56
Balance Plt Area (Net Plot Area - Recreational/Open Space)	(A-Deductions)		91.36
Plot Area for Coverage (Net Plt Area)	(A-Deductions)		101.92
Plot Area for FSI (Net Plt Area + Road/Widening Area)	(A-Deductions)		101.92
Accessorial Area			0.38
<b>COVERAGE CHECK</b>			
Proposed Coverage Area (37.34 %)			59.05
Total Coverage Area (37.34 %)			59.05
<b>FAR CHECK</b>			
Proposed Area of FAR			78.47
Total Area of FAR			78.47
<b>BULKY UP AREA CHECK</b>			
Total Proposed Bulkup Area			78.47
ARCHT/ENGR/SUPERVISOR (Regd)		OWNER	
<b>DEVELOPMENT AUTHORITY</b>			LOCAL BODY

<b>COLOR INDEX</b>	
PROPOSED WORK (COVERAGE AREA)	█
EXISTING (To be retained)	█
EXISTING (To be demolished)	█

<b>MARGIN DETAIL:</b>					
Building/Wing Name	Road Name	Front Margin	Rear Margin	Side1 Margin	Side2 Margin
A1 (POONAM PRASAD)	6.08MROAD	3.20	1.50	0.00	0.93

<b>FAR &amp; Tenement Details (Table 4c-1)</b>					
Building	No. of Same Bldg	Total Built Up Area (Sq.m)	Proposed FAR Area (Sq.m)	Total FAR Area (Sq.m)	Tenm (No.)
A (POONAM PRASAD)	1	78.47	78.47	78.47	01
<b>Grand Total</b>	<b>1</b>	<b>78.47</b>	<b>78.47</b>	<b>78.47</b>	<b>01</b>

<b>Building :A (POONAM PRASAD)</b>				
Floor Name	Total Built Up Area (Sq.m)	Proposed FAR Area (Sq.m)	Total FAR Area (Sq.m)	Tenm (No.)
Ground Floor...	78.47	78.47	78.47	01
First Floor...	19.41	19.41	19.41	00
<b>Total</b>	<b>78.47</b>	<b>78.47</b>	<b>78.47</b>	<b>01</b>
<b>Total Number of Same Buildings</b>				
Total	1	78.47	78.47	01

<b>SCHEDULE OF JOINERY:</b>				
BUILDING NAME	NAME	LENGTH	HEIGHT	NOS
A (POONAM PRASAD)	D2	0.75	2.10	02
A (POONAM PRASAD)	D	1.00	2.10	05
<b>Total</b>	-	-	-	<b>07</b>

<b>SCHEDULE OF JOINERY:</b>				
BUILDING NAME	NAME	LENGTH	HEIGHT	NOS
A (POONAM PRASAD)	V	0.59	1.00	01
A (POONAM PRASAD)	W1	0.84	1.20	01
A (POONAM PRASAD)	W	1.50	1.20	06
<b>Total</b>	-	-	-	<b>08</b>

<b>UnitBUA Table for Building :A (POONAM PRASAD)</b>						
FLOOR	Name	UnitBUA Type	UnitBUA Area	Carpet Area	No. of Rooms	No. of Tenement
GROUND FLOOR PLAN	SPLIT A	PLAT	78.46	70.55	6	1
<b>Total</b>	-	-	<b>78.46</b>	<b>70.55</b>	<b>6</b>	<b>1</b>