

Proposal Basic Information	
Proposal File No.	CMC/BP/0253/W07/2019
Owner Name	MAMTA DEVI
Khata No	638
Plot No	3184
Village Name	Chas
Use	Residential
SubUse	Bungalow/ Dwelling / Non Apartment

AREA STATEMENT CHAS MUNICIPAL CORPORATION		VERSION NO. 1.0.42
PROJECT DETAIL:		VERSION DATE: 29/04/2019
Region: JHARKHAND URBAN LOCAL BODIES	Plot Use: Residential	
District: BOKARO	Plot SubUse: Bungalow/ Dwelling / Non Apartment	
Authority: CHAS MUNICIPAL CORPORATION	PlotNearbyReligiousStructure: NA	
Inward No: CMC/BP/0253/W07/2019	Plot/SubPlot No: 3184	
Application Type: General Proposal	North: Road Width - 4.5	
Project Type: Building Permission	South: Plot No. - SADHNA SINGH	
Nature of Development: New	East: CTS No. - RASTA	
Location of Development Area: New Area	West: Plot No. - 3183	
AREA DETAILS:		SQ.MT.
AREA OF PLOT (Minimum)	(A)	161.93
Deduction for NetPlot Area		
Surrender Free of Cost		9.27
Total		9.27
NET AREA OF PLOT(Gross Plot Area - Deduction from Gross Plot area)	(A-Deductions)	152.66
Deduction for Balance Plot Area(from Gross Plot Area)		
Surrender Free of Cost		9.27
Common Plot		39.22
Total		48.49
BALANCE AREA OF PLOT(Net Plot Area - Recreational/Amenity space)	(A-Deductions)	113.44
PLOT AREA FOR COVERAGE(Net Plot Area)	(A-Deductions)	152.66
Plot Area for FAR (Net Plot Area + RoadWidening Area)	(A-Deductions)	161.93
COVERAGE CHECK		
Permissible Coverage area ( 70.00 % )		106.86
Proposed Coverage Area ( 48.55 % )		74.11
Total Prop. Coverage Area ( 48.55 % )		74.11
Balance coverage area ( 21.45 % )		32.75
FAR CHECK		
Perm. FAR Area ( 1.50 )		242.89
Total Perm. FAR area		242.89
Residential FAR		74.11
Proposed FAR Area		74.11
Total Proposed FAR Area		74.11
Consumed FAR (Factor)		0.46
Balance FAR Area		168.78
BUILT UP AREA CHECK		
Total Proposed BuiltUp Area		74.11
ARCHITECT (Regd)	MANOJ KUMAR	
ENGINEER (Regd)		
SUPERVISOR (Regd)		
OWNER (Regd)	MAMTA DEVI	
DEVELOPMENT AUTHORITY	LOCAL BODY	

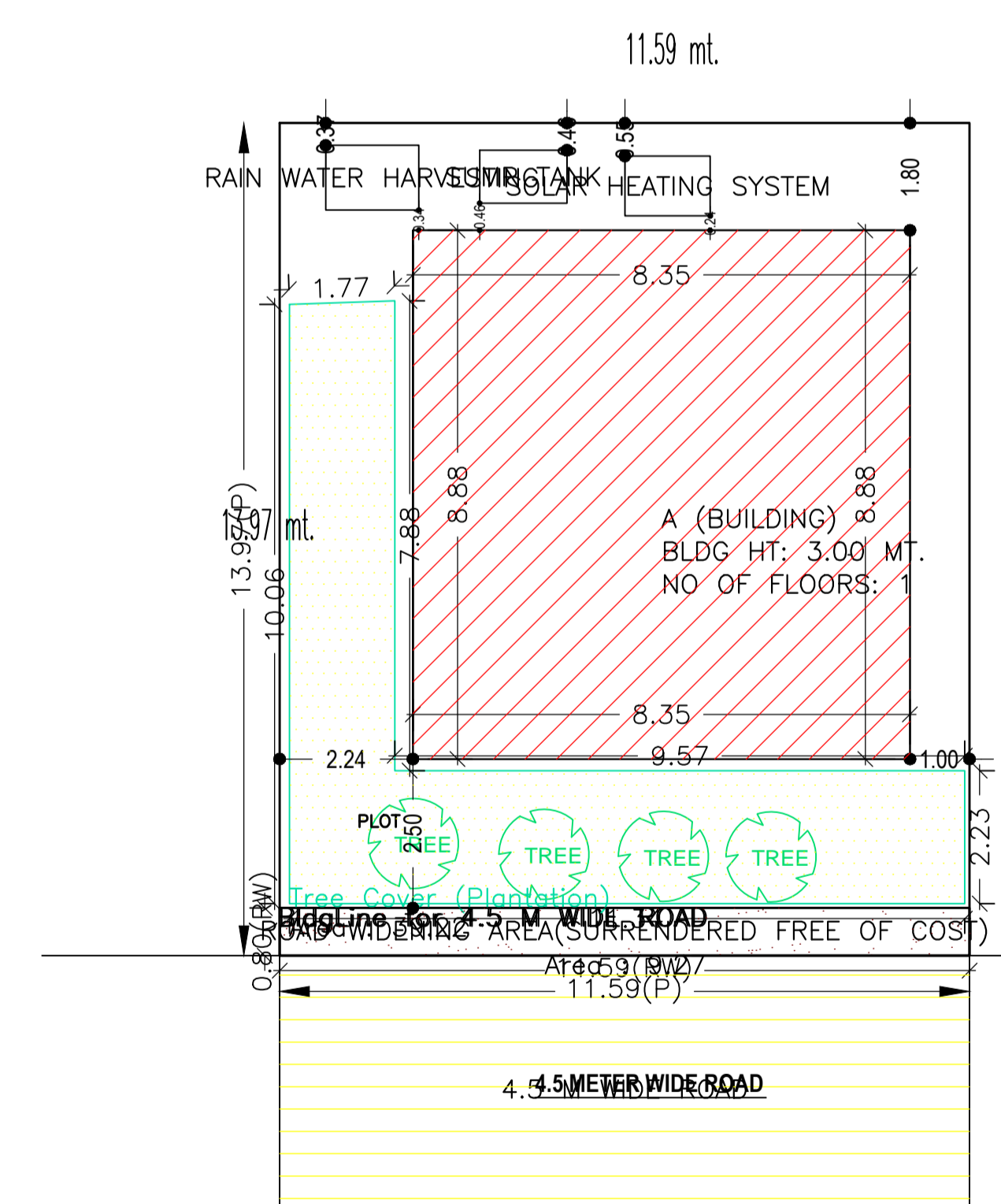
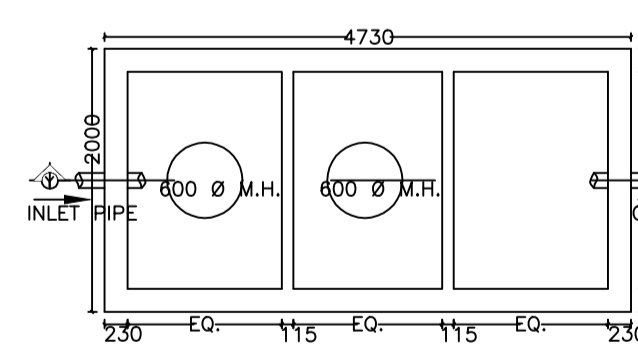
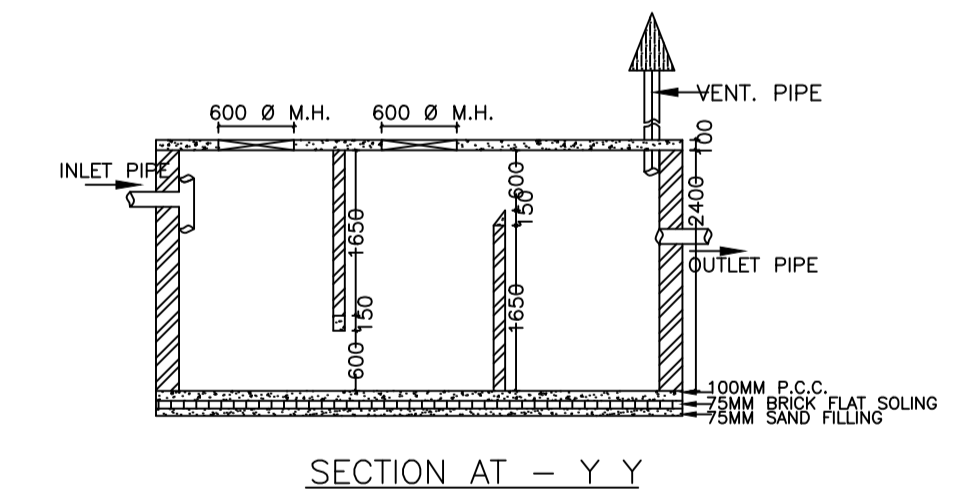
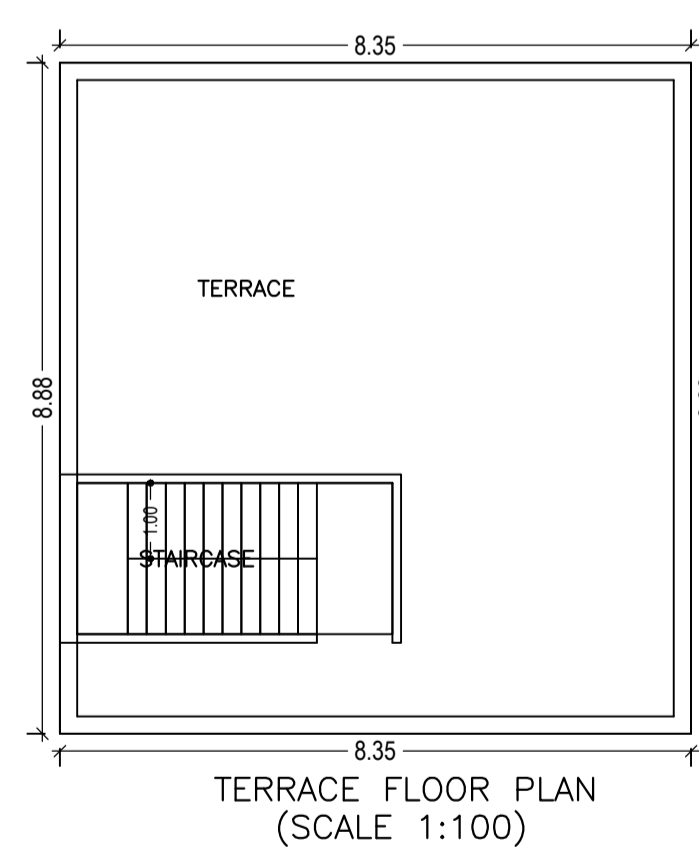
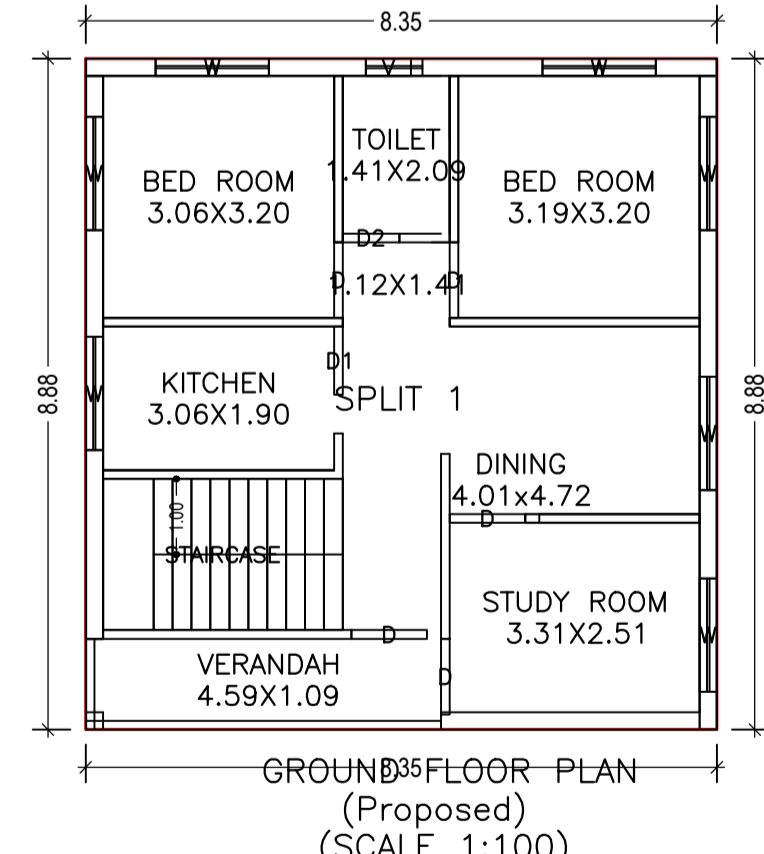
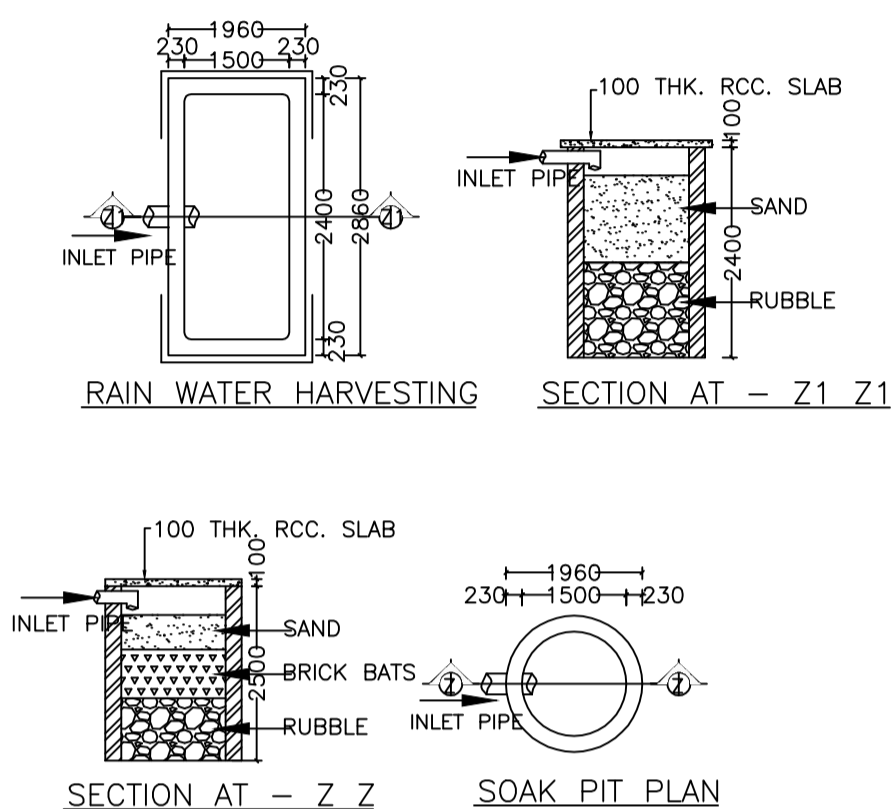
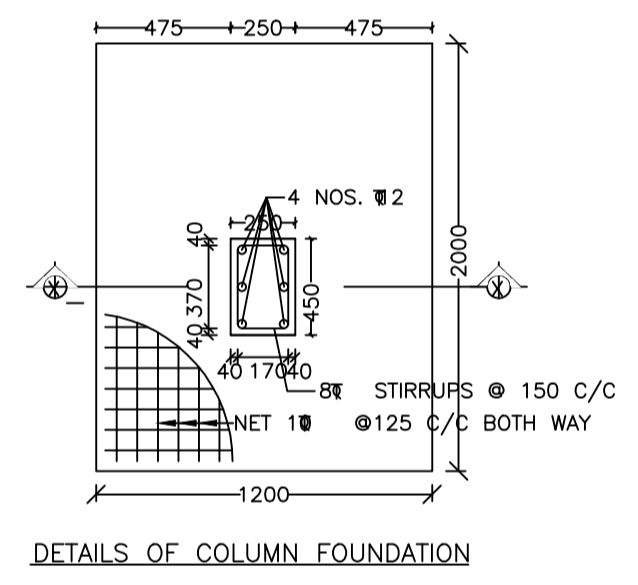
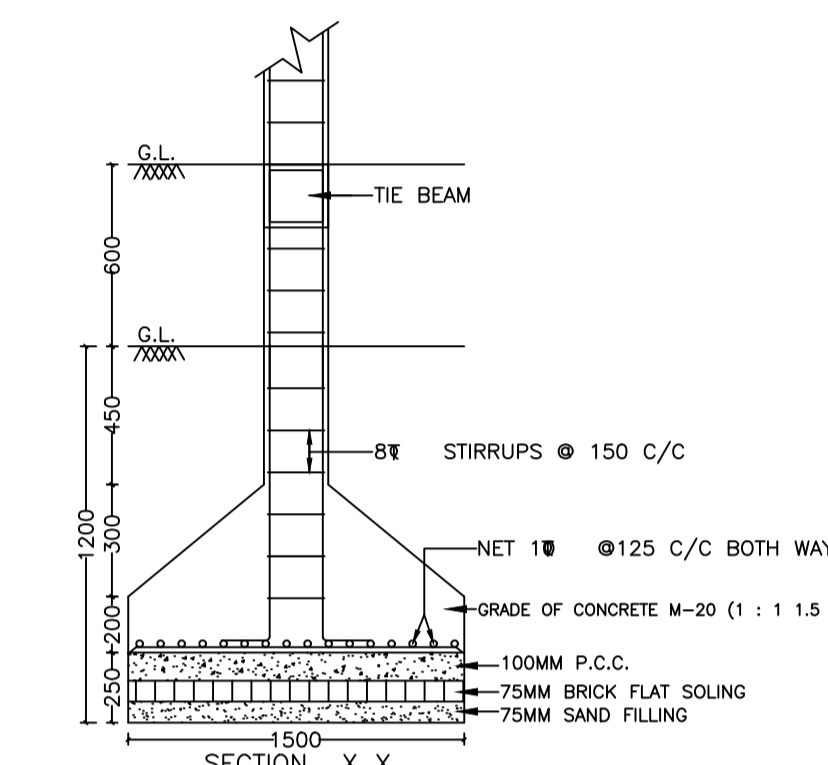
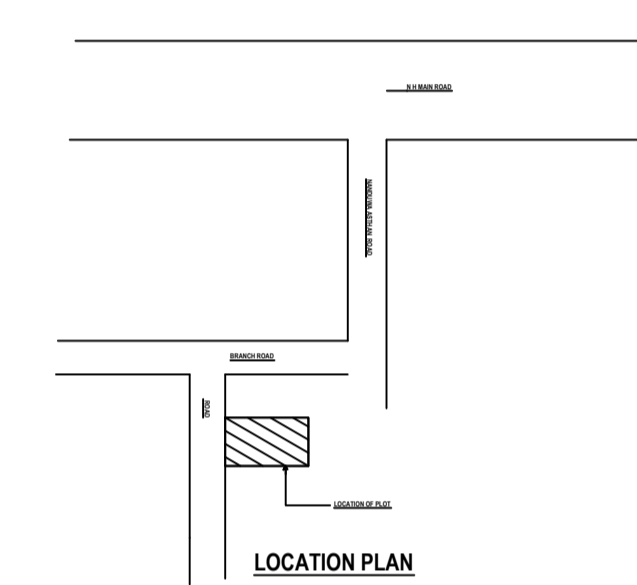
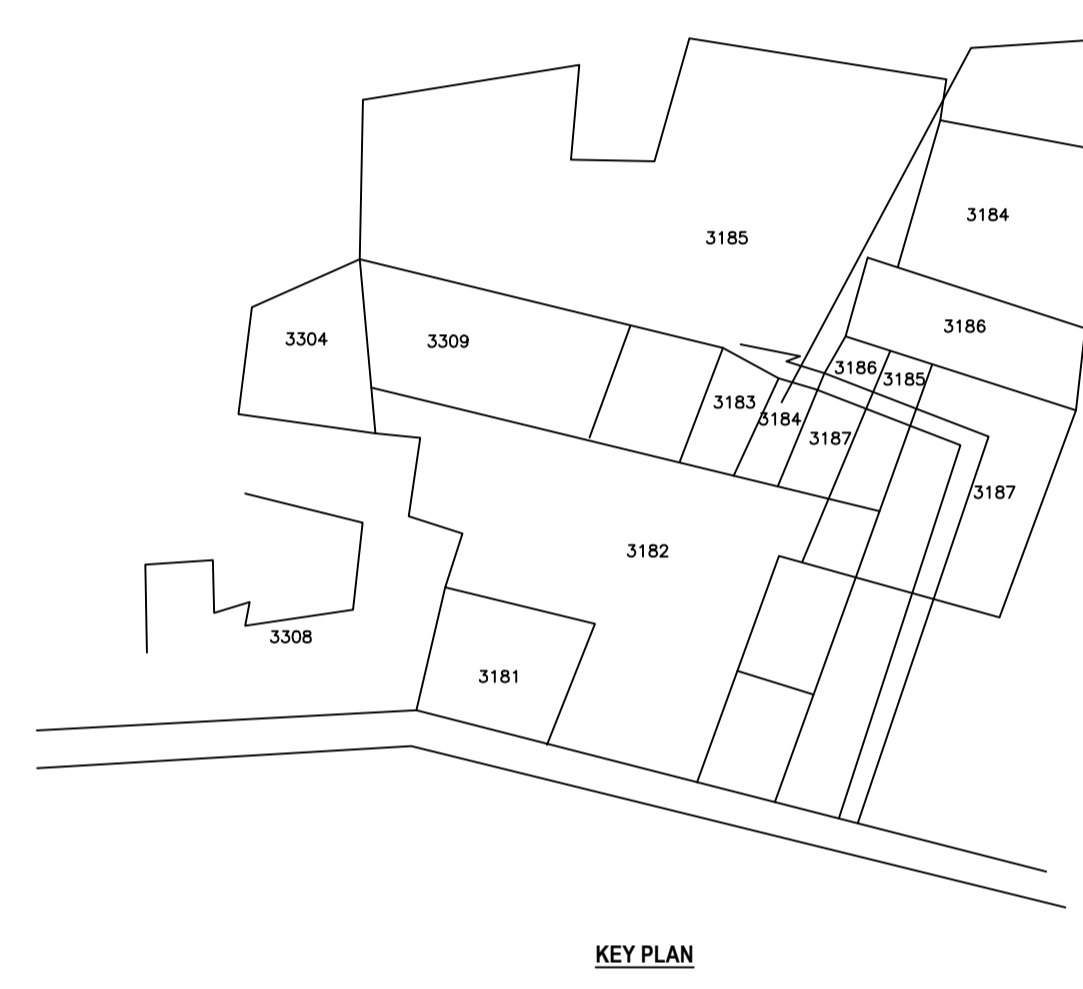

Buildingwise Floor FAR Details				
Floor Name	Building Name		Total	
	Proposed Built Up Area (Sq.mt.)	Proposed FAR Area (Sq.mt.)	Total Proposed Built Up Area (Sq.mt.)	Total FAR Area (Sq.mt.)
Ground Floor	74.11	74.11	74.11	74.11
Terrace Floor	0.00	0.00	0.00	0.00
Total :	74.11	74.11	74.11	74.11

FAR & Tenement Details (Table 4c-1)						
Building	No. of Same Bldg	Total Built Up Area (Sq.mt.)	Proposed FAR Area (Sq.mt.) Resi.	Total FAR Area (Sq.mt.)	Total Consumed Additional FAR Area (Sq.mt.)	Trmt (No.)
A (BUILDING)	1	74.11	74.11	74.11	74.11	01
Grand Total :	1	74.11	74.11	74.11	74.11	01

COLOR INDEX			
PLOT BOUNDARY			
ABUTTING ROAD			
PROPOSED CONSTRUCTION			
COMMON PLOT			
ROAD WIDENING AREA			
EXISTING (To be retained)			
EXISTING (To be demolished)			

Building :A (BUILDING)					
Floor Name	Total Built Up Area (Sq.mt.)	Proposed FAR Area (Sq.mt.) Resi.	Total FAR Area (Sq.mt.)	Total Consumed Additional FAR Area (Sq.mt.)	Trmt (No.)
Ground Floor	74.11	74.11	74.11	74.11	01
Terrace Floor	0.00	0.00	0.00	0.00	00
Total :	74.11	74.11	74.11	74.11	01
Total Number of Same Buildings :	1				
Total :	74.11	74.11	74.11	74.11	01

SCHEDULE OF DOOR:					
BUILDING NAME	NAME	LENGTH	HEIGHT	NOS	
A (BUILDING)	D2	0.75	2.10	01	
A (BUILDING)	D1	0.90	2.10	01	
A (BUILDING)	D	1.00	2.10	05	

SCHEDULE OF WINDOW/VENTILATION:					
BUILDING NAME	NAME	LENGTH	HEIGHT	NOS	
A (BUILDING)	V	0.60	1.20	01	
A (BUILDING)	W	1.50	1.20	07	

Building USE/SUBUSE Details			
Building Name	Building Use	Building SubUse	Building Structure
A (BUILDING)	Residential	Residential Bldg/Apartment	Non-Highrise

UnitBUA Table for Building :A (BUILDING)						
FLOOR	Name	UnitBUA Type	UnitBUA Area	Carpet Area	No. of Rooms	No. of Tenement
GROUND FLOOR PLAN	SPLIT 1	FLAT	60.69	59.18	7	1
Total:	-	-	60.69	59.18	7	1

LTP NAME AND SIGNATURE	STRUCTURAL ENG'S NAME AND SIGNATURE	BUILDER NAME AND SIGNATURE	DIGITAL SIGNATURE
MANOJ KUMAR CMC/SUP/0016/2018			