

Proposal Basic Information

Proposal File No.	CMC/BP/0267/W30/2019
Owner Name	USHA SAHU
Khata No	28
Plot No	978
Village Name	Bandhgora
Use	Residential
SubUse	Bungalow/ Dwelling / Non Apartment

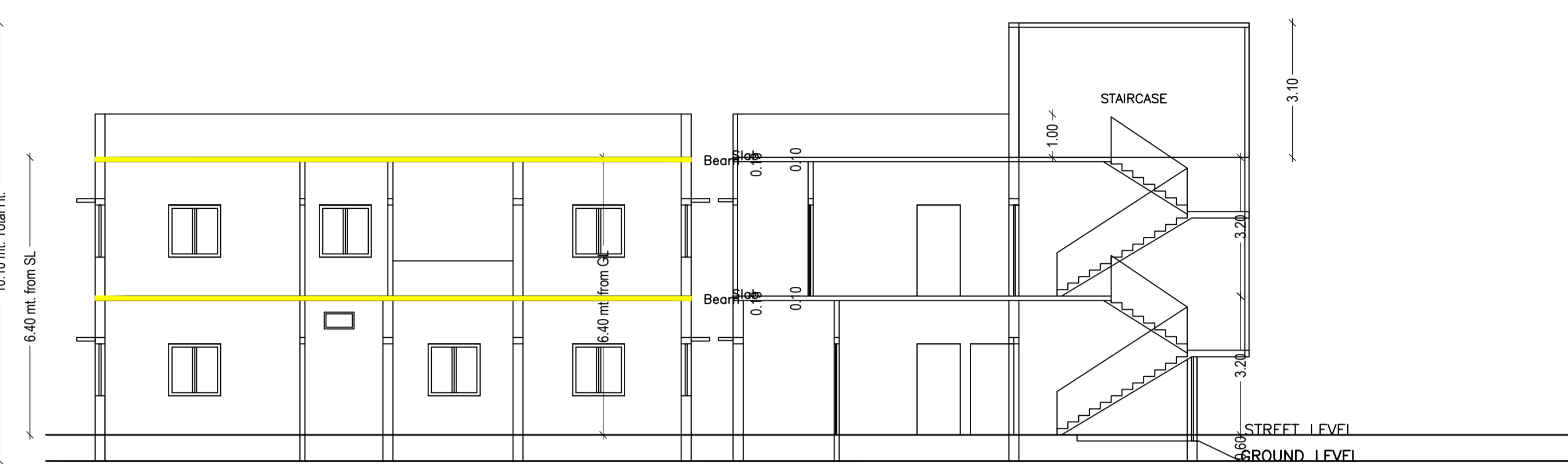
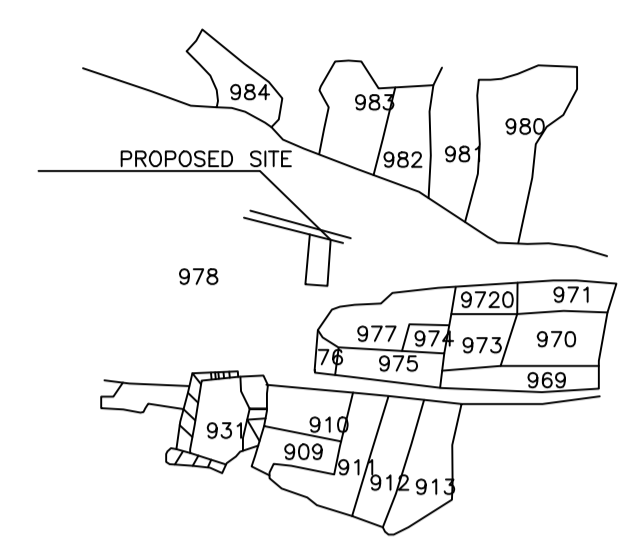
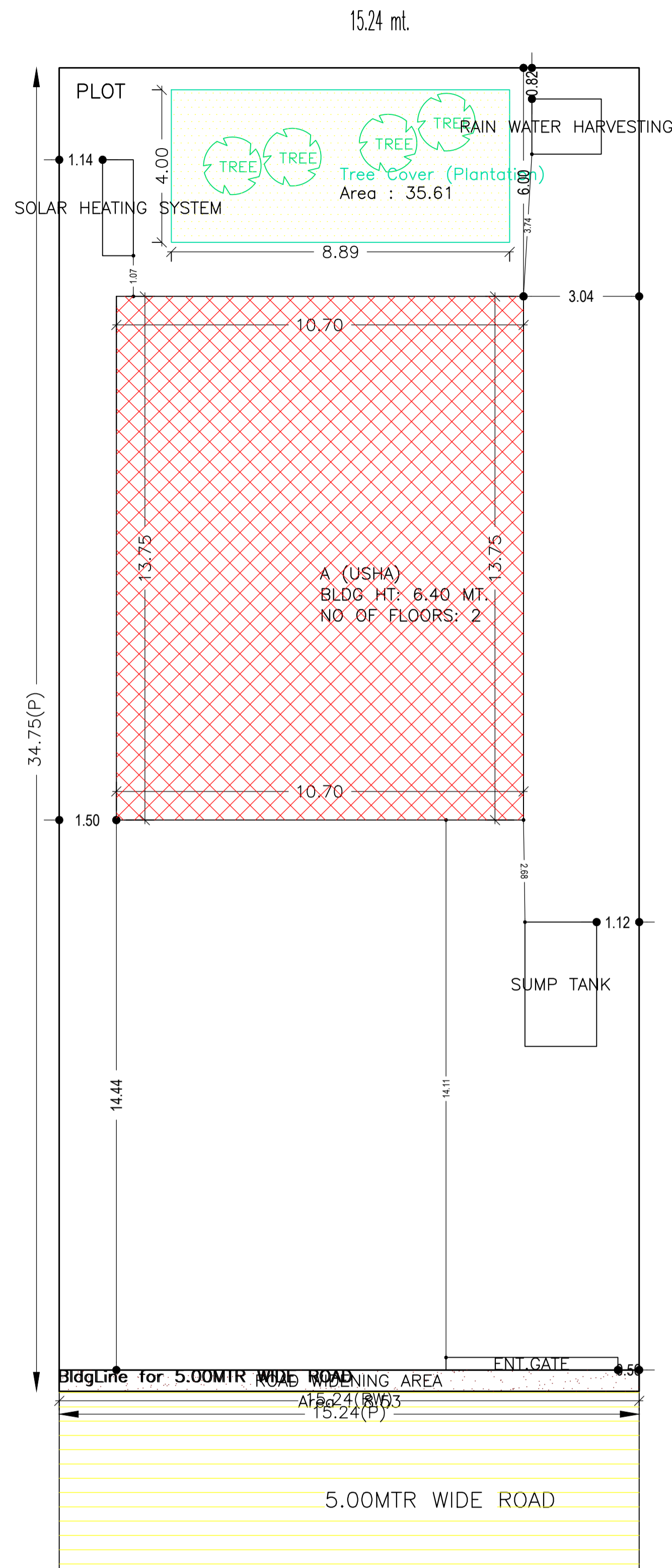

SECTION AT - A-A'

SECTION AT - B-B'

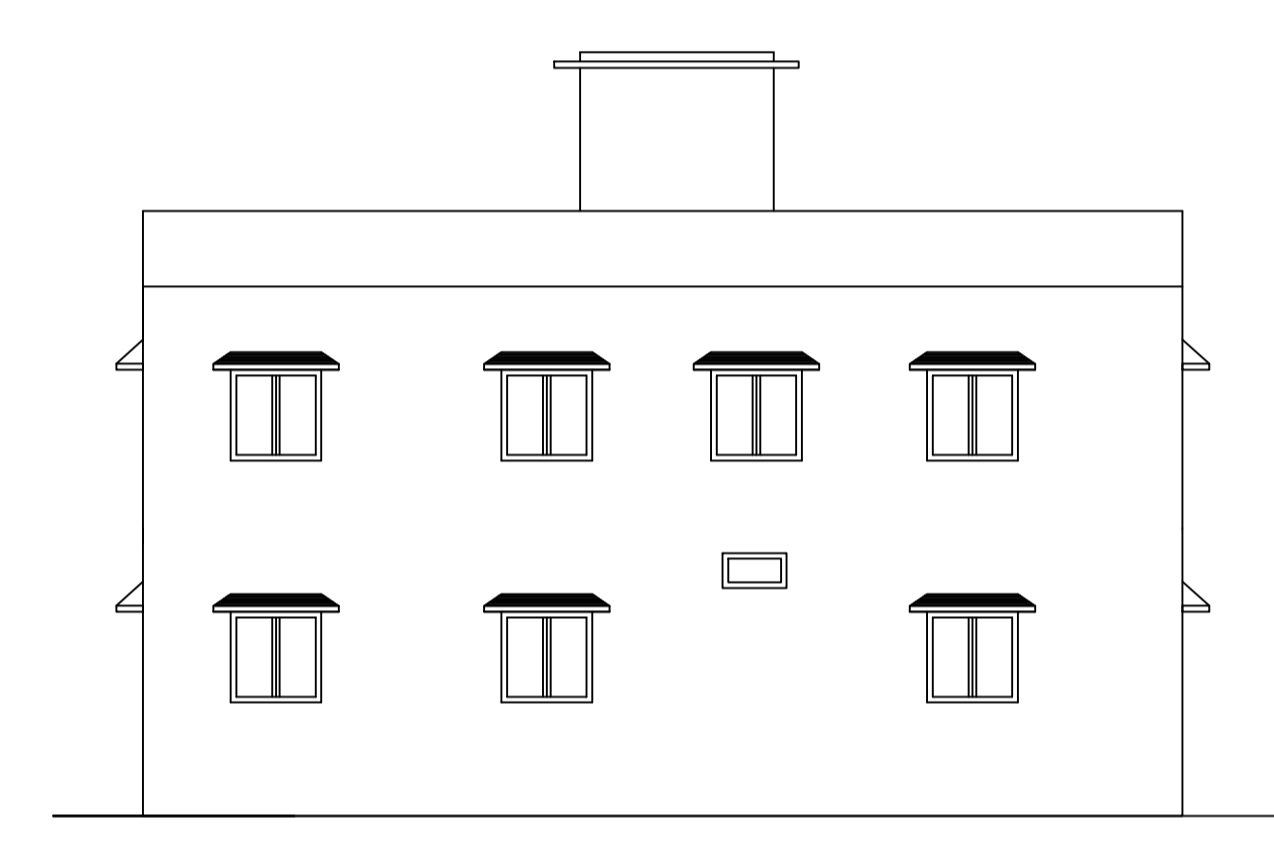
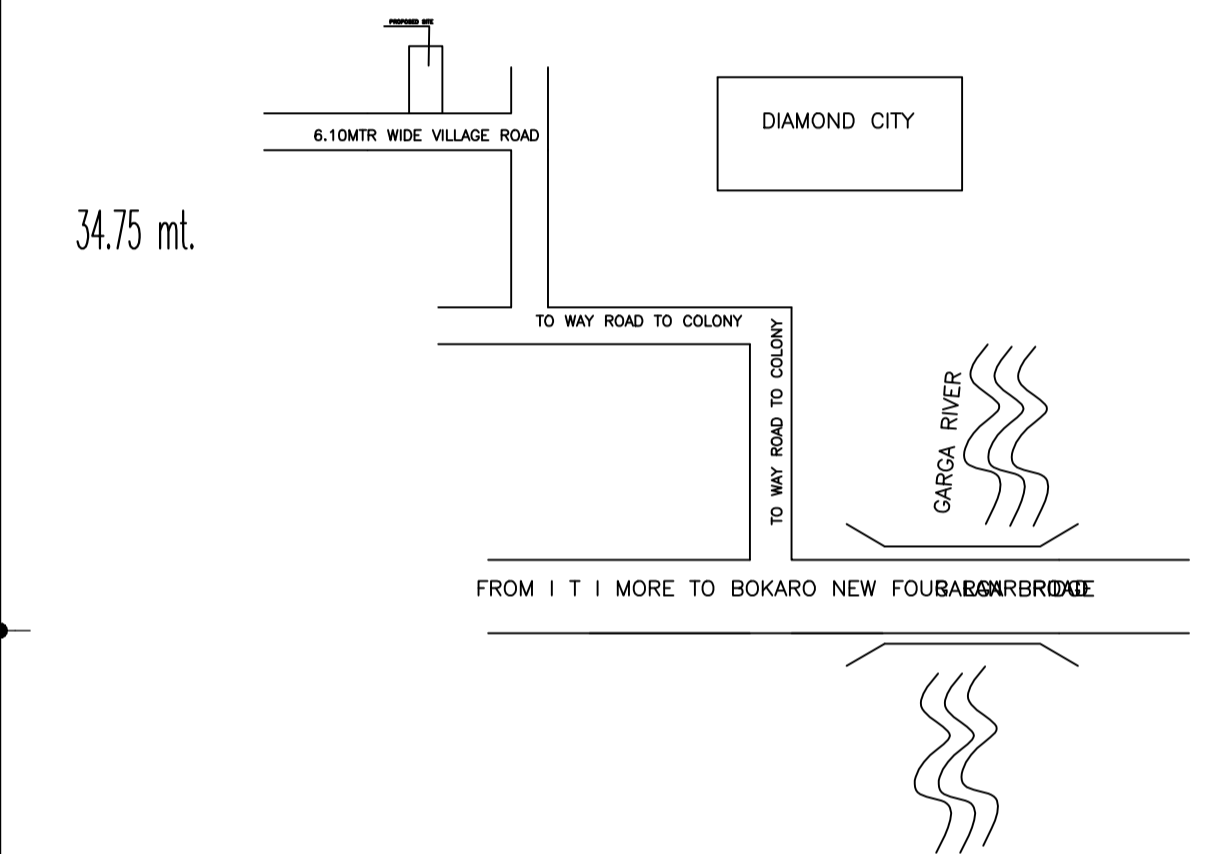

SIDE ELEVATION

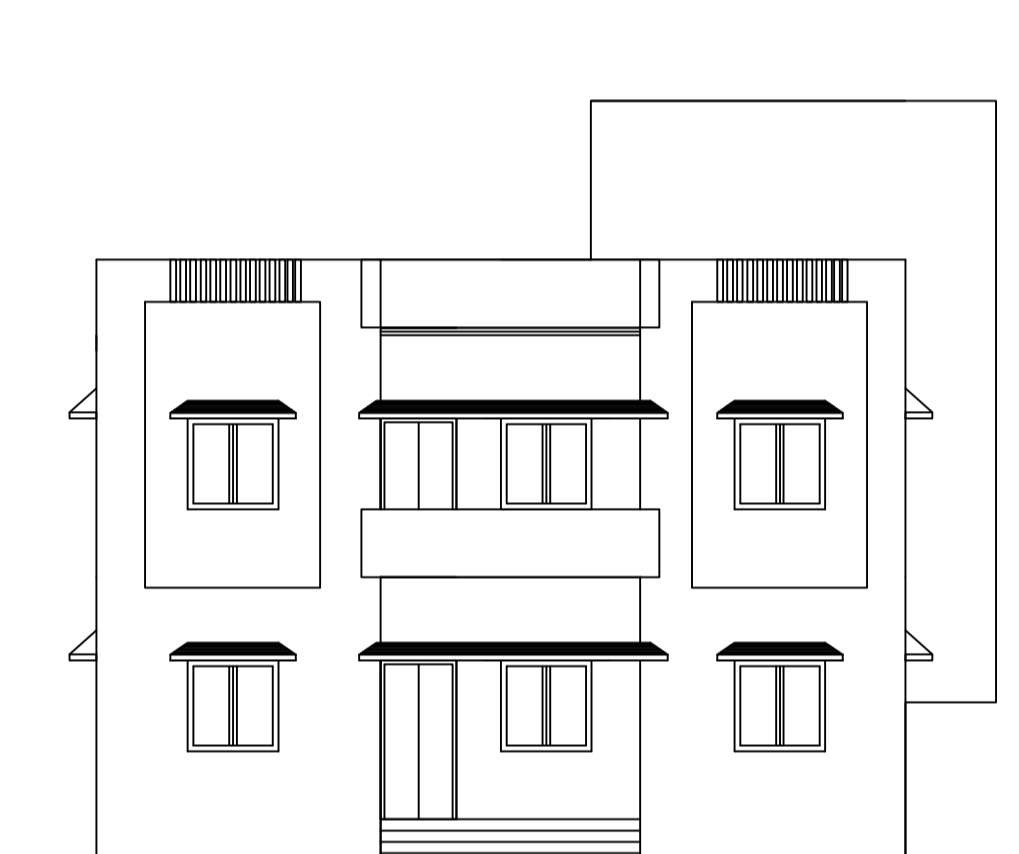

FRONT ELEVATION

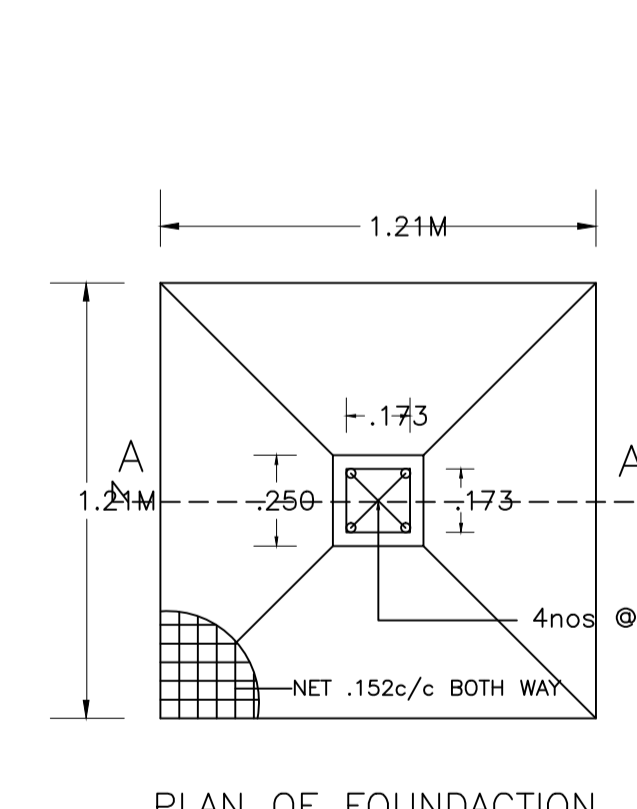

PLAN OF FOUNDATION

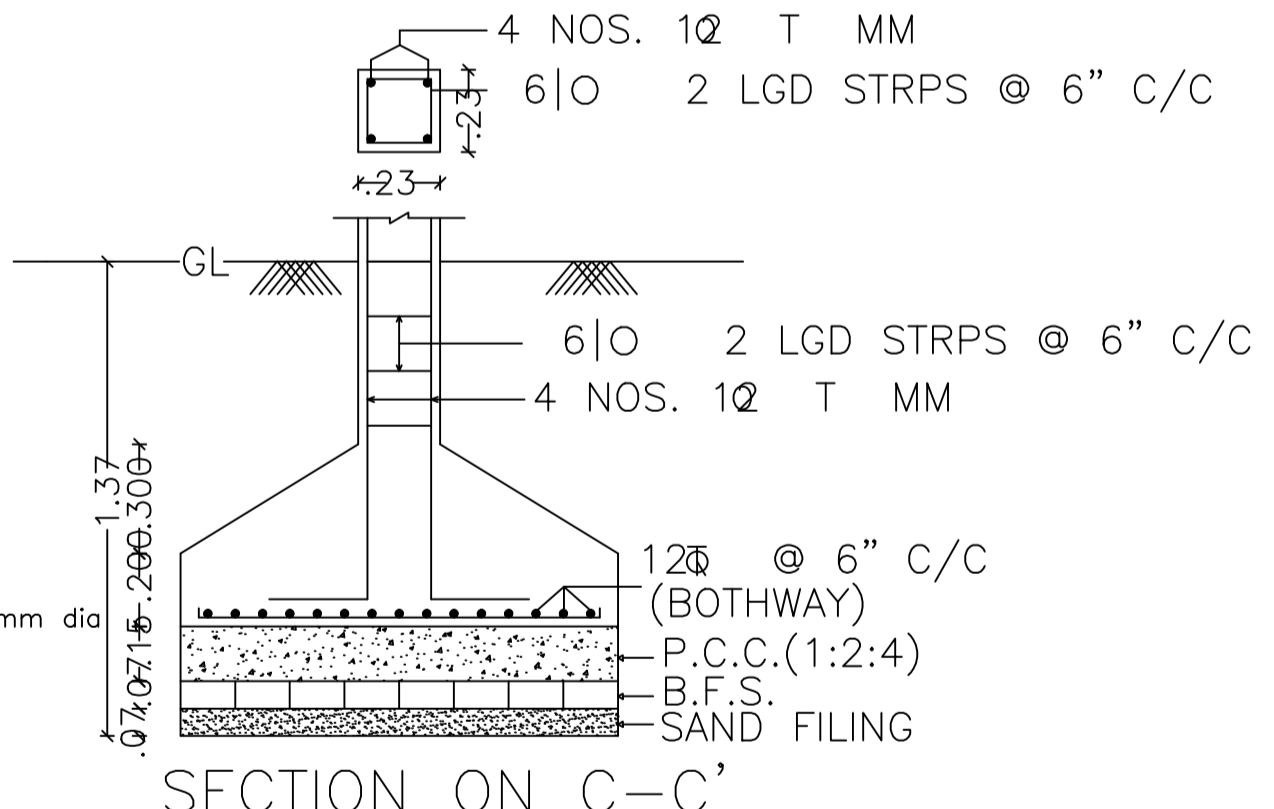

SECTION ON C-C'

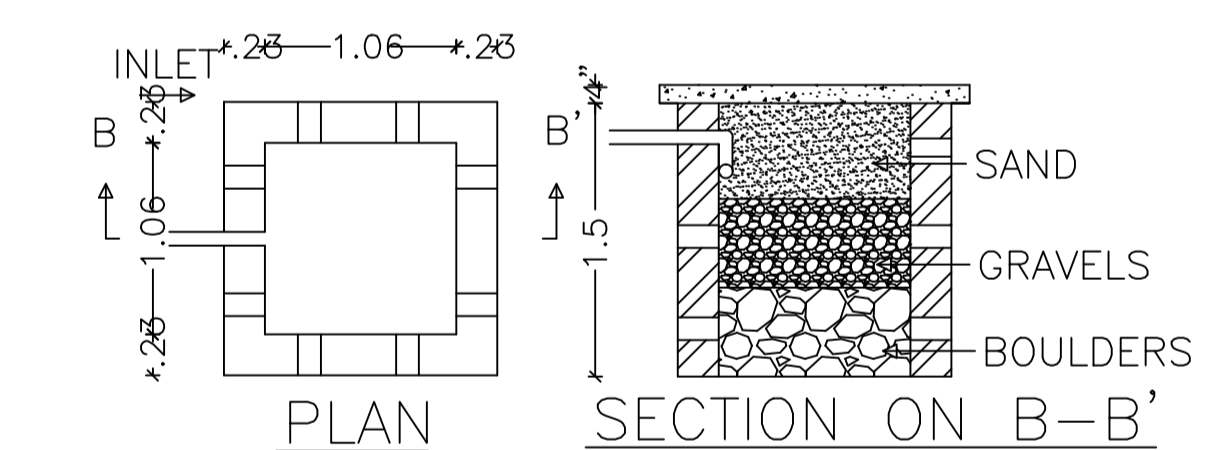

DETAILS OF WATER HARVESTING

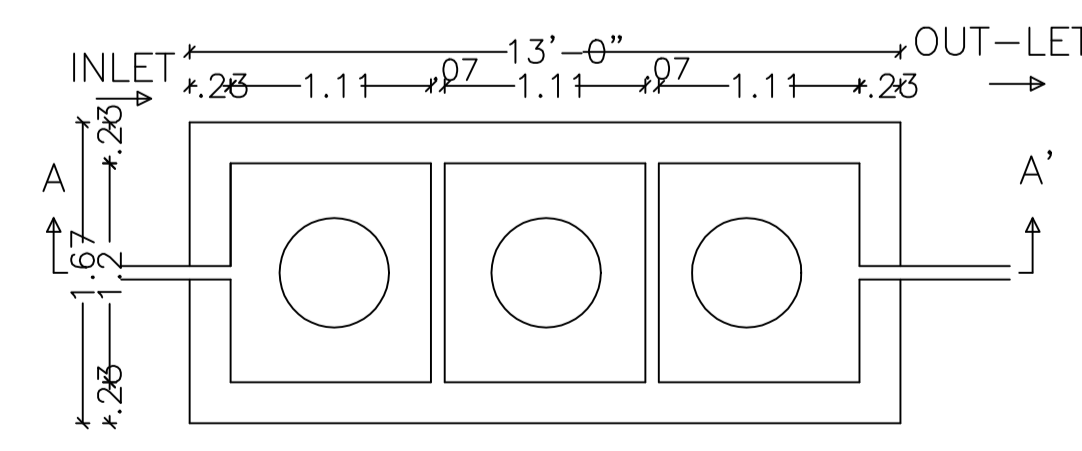

PLAN

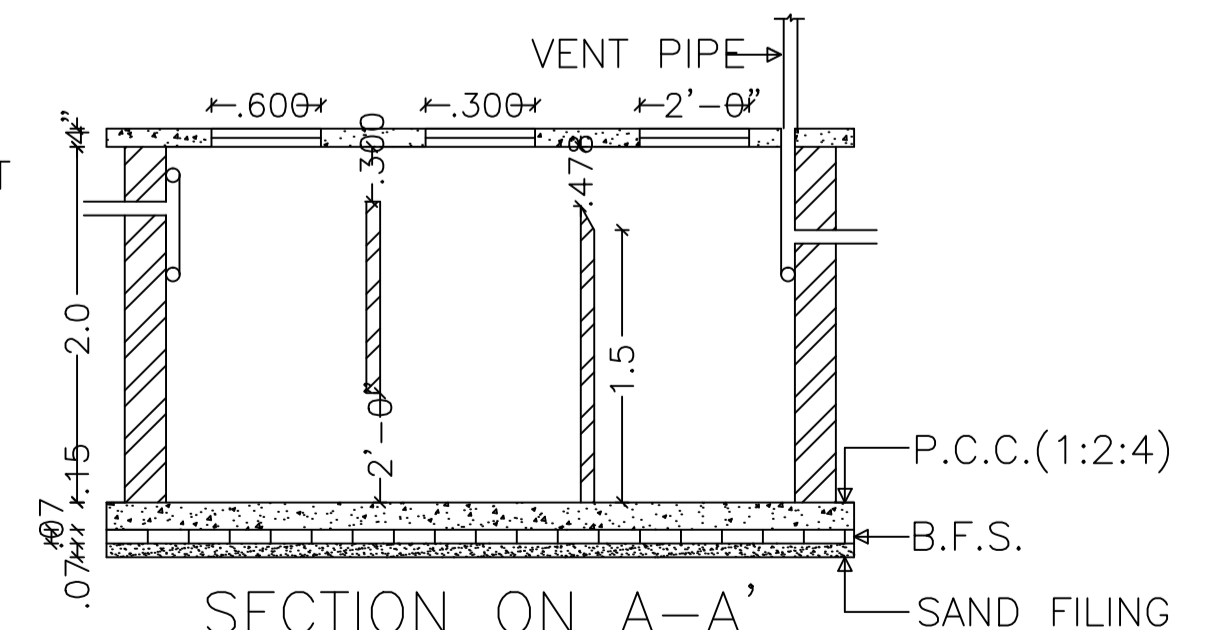

SECTION ON A-A'

AREA STATEMENT CHAS MUNICIPAL CORPORATION		VERSION NO.: 1.0.43
PROJECT DETAIL:		VERSION DATE: 29/04/2019
Region: JHARKHAND URBAN LOCAL BODIES	Plot Use: Residential	
District: BOKARO	Plot SubUse: Bungalow/ Dwelling / Non Apartment	
Authority: CHAS MUNICIPAL CORPORATION	Plot/Nearby/Religious/Structure: NA	
Inward No: CMC/BP/0267/W30/2019	Plot/SubPlot No: 978	
Application Type: General Proposal	North: Road Width - 6.10 MTR WIDE ROAD	
Project Type: Building Permission	South: CTS No. - PART OF PLOT	
Nature of Development: New	East: CTS No. - PART OF PLOT	
Location of Development Area: New Area	West: CTS No. - RAMGUNJ DEVI	
AREA DETAILS:		SQ.MT.
AREA OF PLOT (Minimum)	(A)	529.59
Deduction for NetPlot Area		
Road Widening Area		8.53
Total		8.53
NET AREA OF PLOT(Gross Plot Area - Deduction from Gross Plot area)	(A-Deductions)	521.06
Deduction for Balance Plot Area(from Gross Plot Area)		
Road Widening Area		8.53
Common Plot		35.61
Total		44.15
BALANCE AREA OF PLOT(Net Plot Area - Recreational/Amenity space)	(A-Deductions)	485.44
PLOT AREA FOR COVERAGE(Net Plot Area)	(A-Deductions)	521.06
Plot Area for FAR (Net Plot Area + RoadWidening Area)	(A-Deductions)	521.06
COVERAGE CHECK		
Permissible Coverage area ( 60.00 % )		312.64
Proposed Coverage Area ( 28.24 % )		147.13
Total Prop. Coverage Area ( 28.24 % )		147.13
Balance coverage area ( 31.76 % )		165.51
FAR CHECK		
Perm. FAR Area ( 1.80 )		937.91
Total Perm. FAR area		937.91
Residential FAR		294.25
Proposed FAR Area		294.25
Total Proposed FAR Area		294.25
Consumed FAR (Factor)		0.56
Balance FAR Area		643.66
BUILT UP AREA CHECK		
Total Proposed BuiltUp Area		294.26
ARCHITECT (Regd)	Suresh Prasad Singh	
ENGINEER (Regd)		
SUPERVISOR (Regd)		
OWNER (Regd)	USHA SAHU	
DEVELOPMENT AUTHORITY		LOCAL BODY

COLOR INDEX	
PLOT BOUNDARY	Black
ABUTTING ROAD	Green
PROPOSED CONSTRUCTION	Red
COMMON PLOT	Yellow
ROAD WIDENING AREA	Blue
EXISTING (To be retained)	Orange
EXISTING (To be demolished)	Purple

Floor Name	Building Name A (USHA)		Total	
	Proposed Built Up Area (Sq.mt.)	Proposed FAR Area (Sq.mt.)	Total Proposed Built Up Area (Sq.mt.)	Total FAR Area (Sq.mt.)
Ground Floor	147.13	147.13	147.13	147.13
First Floor	147.13	147.13	147.13	147.13
Terrace Floor	0.00	0.00	0.00	0.00
Total:	294.26	294.26	294.26	294.26

Building :A (USHA)					
Floor Name	Total Built Up Area (Sq.mt.)	Proposed FAR Area (Sq.mt.)	Total FAR Area (Sq.mt.)	Total Consumed Additional FAR Area (Sq.mt.)	Tnmt (No.)
Ground Floor	147.13	147.13	147.13	147.13	01
First Floor	147.13	147.13	147.13	147.13	00
Terrace Floor	0.00	0.00	0.00	0.00	00
Total:	294.26	294.26	294.26	294.26	01
Total Number of Same Buildings	1				
Total:	294.26	294.26	294.26	294.26	01

SITE PLAN

BUILDING NAME	NAME	LENGTH	HEIGHT	NOS
A (USHA)	D2	0.75	2.10	04
A (USHA)	D1	0.90	2.10	05
A (USHA)	D	1.00	2.10	12
A (USHA)	D	1.02	2.10	01
A (USHA)	D	1.09	2.10	01

BUILDING NAME	NAME	LENGTH	HEIGHT	NOS
A (USHA)	V	0.76	1.20	04
A (USHA)	V	0.98	1.20	01
A (USHA)	W	1.30	1.20	22

FAR & Tenement Details (Table 4c-1)

Building	No. of Same Bldg	Total Built Up Area (Sq.mt.)	Proposed FAR Area (Sq.mt.)	Total FAR Area (Sq.mt.)	Total Consumed Additional FAR Area (Sq.mt.)	Tnmt (No.)
A (USHA)	1	294.26	294.26	294.26	294.26	01
Grand Total:	1	294.26	294.26	294.26	294.26	01

UnitBUA Table for Building :A (USHA)

FLOOR	Name	UnitBUA Type	UnitBUA Area	Carpet Area	No. of Rooms	No. of Tenement
GROUND FLOOR PLAN	SPLIT A	FLAT	294.25	294.14	12	1
FIRST FLOOR PLAN	SPLIT A	FLAT	0.00	0.00	14	0
Total:	-	-	294.25	294.14	26	1

Building USE/SUBUSE Details

Building Name	Building Use	Building SubUse	Building Structure
A (USHA)	Residential	Bungalow/ Dwelling / Non Apartment	Non-Highrise

LTP NAME AND SIGNATURE	STRUCTURAL ENG'S NAME AND SIGNATURE	BUILDER NAME AND SIGNATURE	DIGITAL SIGNATURE
Suresh Prasad Singh CMC/ENG/0002/2017			

