

Project Title :SMT.GAYTRI.DEV1

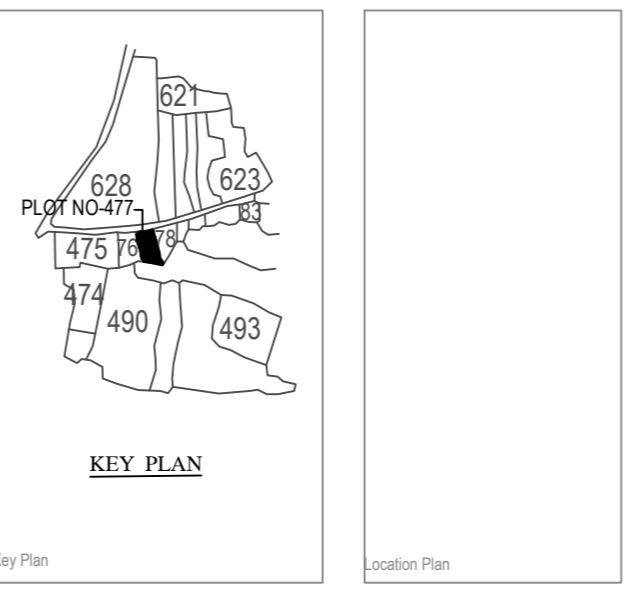
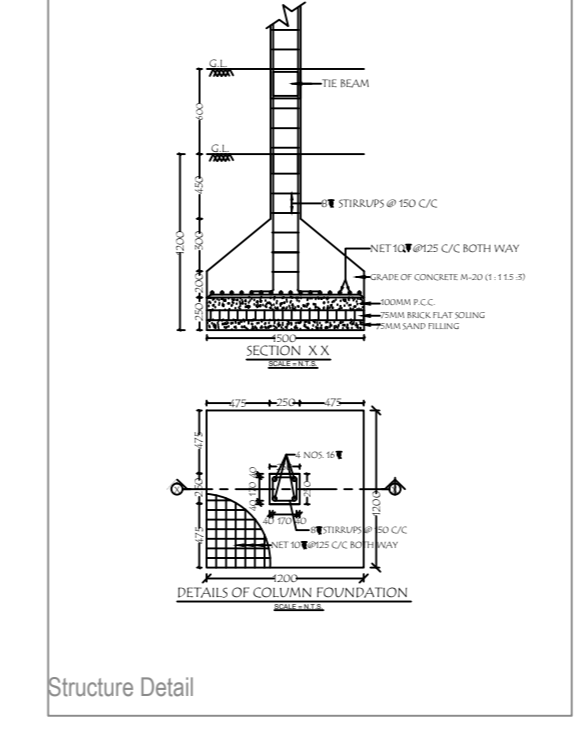
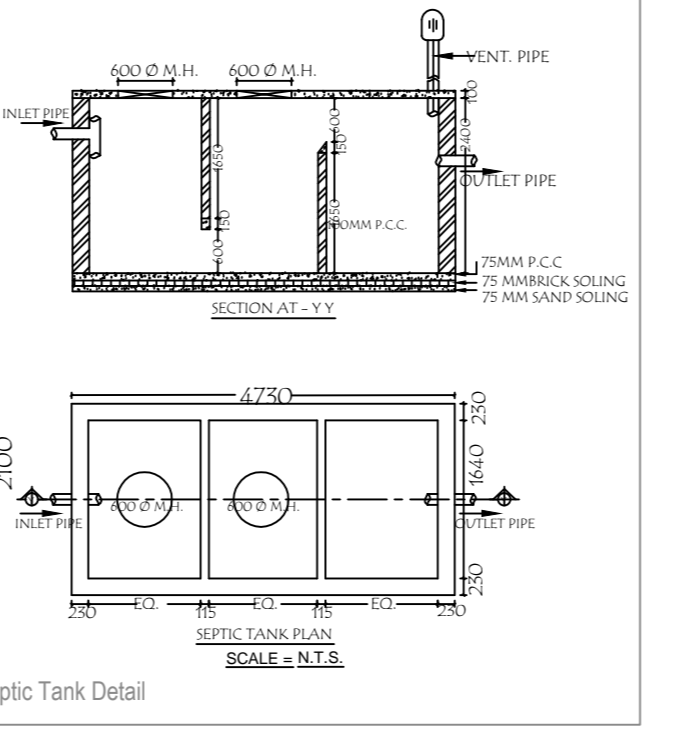
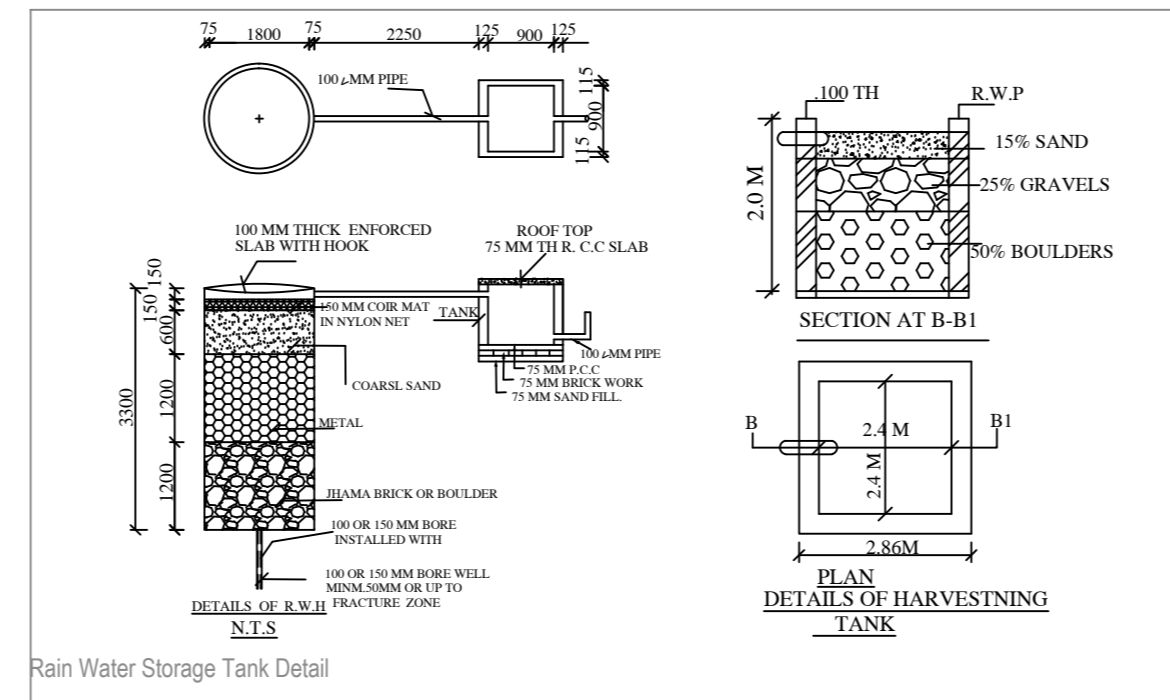
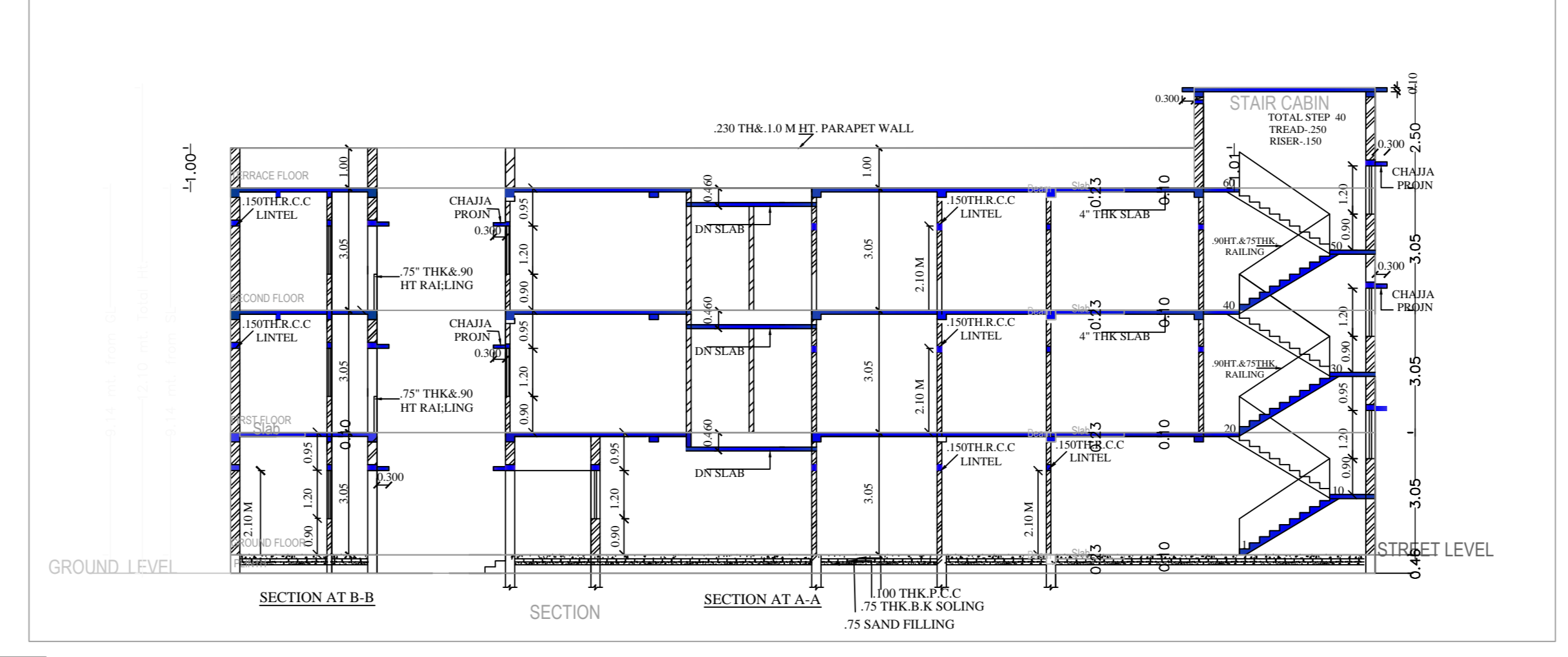
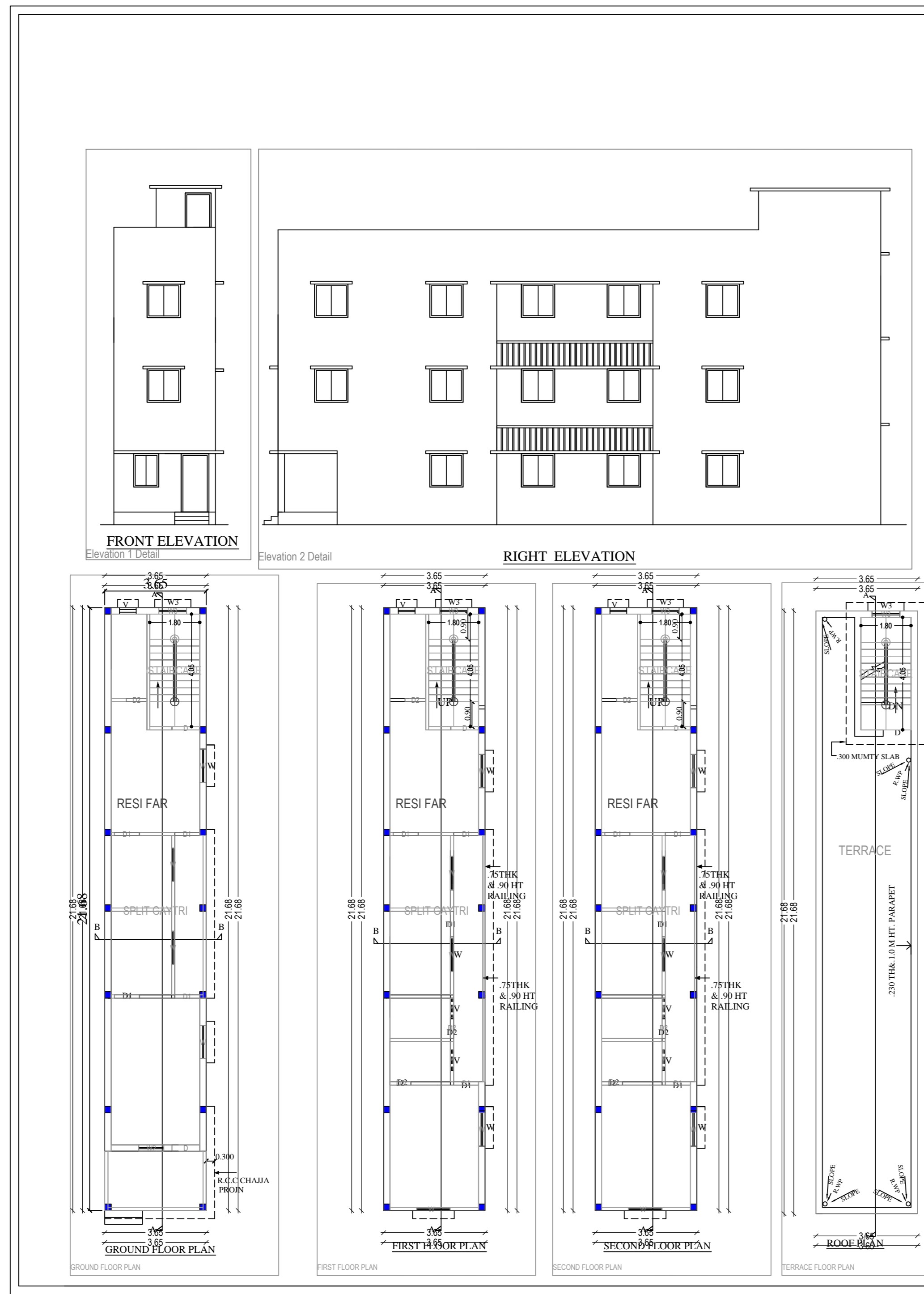

- BRIEF SPECIFICATION**
- FOUNDATION: RIGID DEPTH WITH P.C.C 1:4:8 & 150 THK.
 - R.C.C. COLUMNS IN 1:2:8.
 - FLOORING: 25 MM THK 1:1.5 FLOORING
 - WORK: WOOD IN S&S WOOD
 - PAINTING: O.C.T. SIDE KNOW IN S&S DISTEMPERING

SCHEDULES OF DOORS, WINDOW & VENTILATORS

TYPE	SIZE	DESCRIPTION
D1	1.0 X 2.10	PANELLED DOOR
D2	2.0 X 2.10	PANELLED DOOR
D3	2.0 X 2.10	PANELLED DOOR
W	1.20 X 1.20	STEEL FRAME WITH GLASS PANEL
W1	1.20 X 1.20	STEEL FRAME WITH GLASS PANEL
W2	1.20 X 1.20	STEEL FRAME WITH GLASS PANEL
V	1.20 X 0.60	VENTILATORS GLAZED
V1	2.00 X 0.60	VENTILATORS GLAZED

STATEMENT OF AREA

TOTAL PLOT AREA	121.31 SQ.M
GROUND FLOOR AREA	79.11 SQ.M
FIRST FLOOR AREA	79.11 SQ.M
TOTAL COV. AREA	158.22 SQ.M
F.A.R	

SMR ARCHITECT & PLANNERS
 F-5 CITY CENTER B.S. CITY
 PROPOSED RESIDENTIAL BUILDING OF

OWNER: ARCHITECT
ARCHITECT: ARCHITECT

SURBHAJIN NETHRAGANAKAR
 SURBHAJIN NETHRAGANAKAR
 LIC. NO. CM/AR/06/0014

PROJECT DETAIL:

PROJECT NAME	SMT.GAYTRI.DEV1
REGION	REGION
APPLICANT	APPLICANT
DATE	DATE

ANALYSIS:

NET PLOT AREA	121.31
NET PLOT AREA FROM PLOT AREA	121.31
COV. AREA	158.22
COV. AREA FOR COVERAGE	158.22
COV. AREA FOR COVERAGE	158.22
COV. AREA FOR COVERAGE	158.22
COV. AREA FOR COVERAGE	158.22

COLOR INDEX

Color	Index
Color	Index
Color	Index
Color	Index

MARGIN DETAIL:

Building / Wing	Road Name	Front Margin	Rear Margin	Side Margin	Side Margin
SMR	6.00 MTR MAIN ROAD	3.00	1.80	0.00	0.00

Building / Wing / Area (Sq.M)

Building / Wing	No. of Same Bldg	Total Bldg. Area (Sq.M)	Proposed FAR Area (Sq.M)	Total FAR Area (Sq.M)	Terr. (No.)
SMR (BUILDING)	1	237.33	237.33	237.33	01
Grand Total	1	237.33	237.33	237.33	01

Building SMR (BUILDING)

Floor Name	Total Bldg. Area (Sq.M)	Proposed FAR Area (Sq.M)	Total FAR Area (Sq.M)	Terr. (No.)
Ground Floor	79.11	79.11	79.11	01
First Floor	79.11	79.11	79.11	00
Second Floor	79.11	79.11	79.11	00
Terrace Floor	0.00	0.00	0.00	00
Total	237.33	237.33	237.33	01
Total Number of Same Building	1			
Total	237.33	237.33	237.33	01

SCHEDULE OF JOINERY:

BUILDING NAME	NAME	LENGTH	HEIGHT	NOS
SMR BUILDING	D1	0.75	2.10	12
SMR BUILDING	D2	0.90	2.10	12
SMR BUILDING	D3	1.00	2.10	12
Total				36

SCHEDULE OF JOINERY:

BUILDING NAME	NAME	LENGTH	HEIGHT	NOS
SMR BUILDING	V	0.90	1.20	36
SMR BUILDING	W	0.90	1.20	36
SMR BUILDING	W1	1.00	1.20	36
SMR BUILDING	W2	1.20	1.20	36
Total				144

Unit/BUA Table for Building SMR (BUILDING)

FLOOR	Name	Unit/BUA Type	Unit/BUA Area	Coverd Area	No. of Units	No. of Terrace
GROUND FLOOR PLAN	SPLIT GAYTRI	FLAT	194.23	177.07	1	00
Total			194.23	177.07	1	00

