

GENERAL INFORMATION	
Project Name	PEOPINI DEVI, 2. RAMCHANDRA PRASAD, SINGH AND OTHERS
Client Name	
Location	
Area	
Volume	
Height	
Structure Type	
Foundation Type	
Design Period	
Design Team	
Scale	
Revision	
Drawn By	
Checked By	
Approved By	
Date	

COLOR KEY	
Structure	Black
Foundation	Red
Roof	Blue
Interior	Green
Exterior	Yellow
Other	Purple

AREA & VOLUME DATA (Table No. 1)		
Room No.	Area (sq. m)	Volume (cu. m)
1	100	1000
2	200	2000
3	300	3000
4	400	4000
5	500	5000
6	600	6000
7	700	7000
8	800	8000
9	900	9000
10	1000	10000
11	1100	11000
12	1200	12000
13	1300	13000
14	1400	14000
15	1500	15000
16	1600	16000
17	1700	17000
18	1800	18000
19	1900	19000
20	2000	20000
21	2100	21000
22	2200	22000
23	2300	23000
24	2400	24000
25	2500	25000
26	2600	26000
27	2700	27000
28	2800	28000
29	2900	29000
30	3000	30000
31	3100	31000
32	3200	32000
33	3300	33000
34	3400	34000
35	3500	35000
36	3600	36000
37	3700	37000
38	3800	38000
39	3900	39000
40	4000	40000
41	4100	41000
42	4200	42000
43	4300	43000
44	4400	44000
45	4500	45000
46	4600	46000
47	4700	47000
48	4800	48000
49	4900	49000
50	5000	50000
51	5100	51000
52	5200	52000
53	5300	53000
54	5400	54000
55	5500	55000
56	5600	56000
57	5700	57000
58	5800	58000
59	5900	59000
60	6000	60000
61	6100	61000
62	6200	62000
63	6300	63000
64	6400	64000
65	6500	65000
66	6600	66000
67	6700	67000
68	6800	68000
69	6900	69000
70	7000	70000
71	7100	71000
72	7200	72000
73	7300	73000
74	7400	74000
75	7500	75000
76	7600	76000
77	7700	77000
78	7800	78000
79	7900	79000
80	8000	80000
81	8100	81000
82	8200	82000
83	8300	83000
84	8400	84000
85	8500	85000
86	8600	86000
87	8700	87000
88	8800	88000
89	8900	89000
90	9000	90000
91	9100	91000
92	9200	92000
93	9300	93000
94	9400	94000
95	9500	95000
96	9600	96000
97	9700	97000
98	9800	98000
99	9900	99000
100	10000	100000

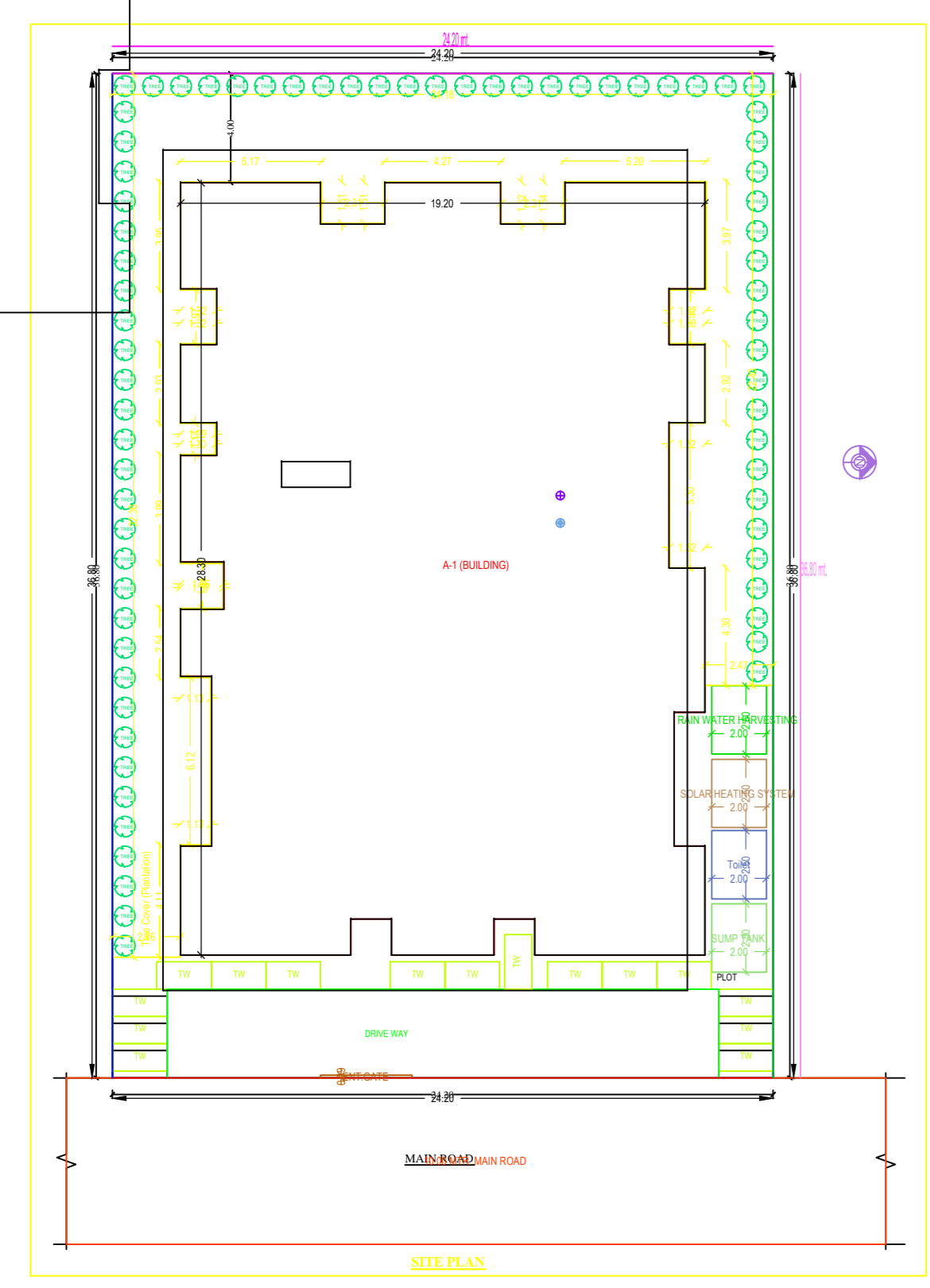
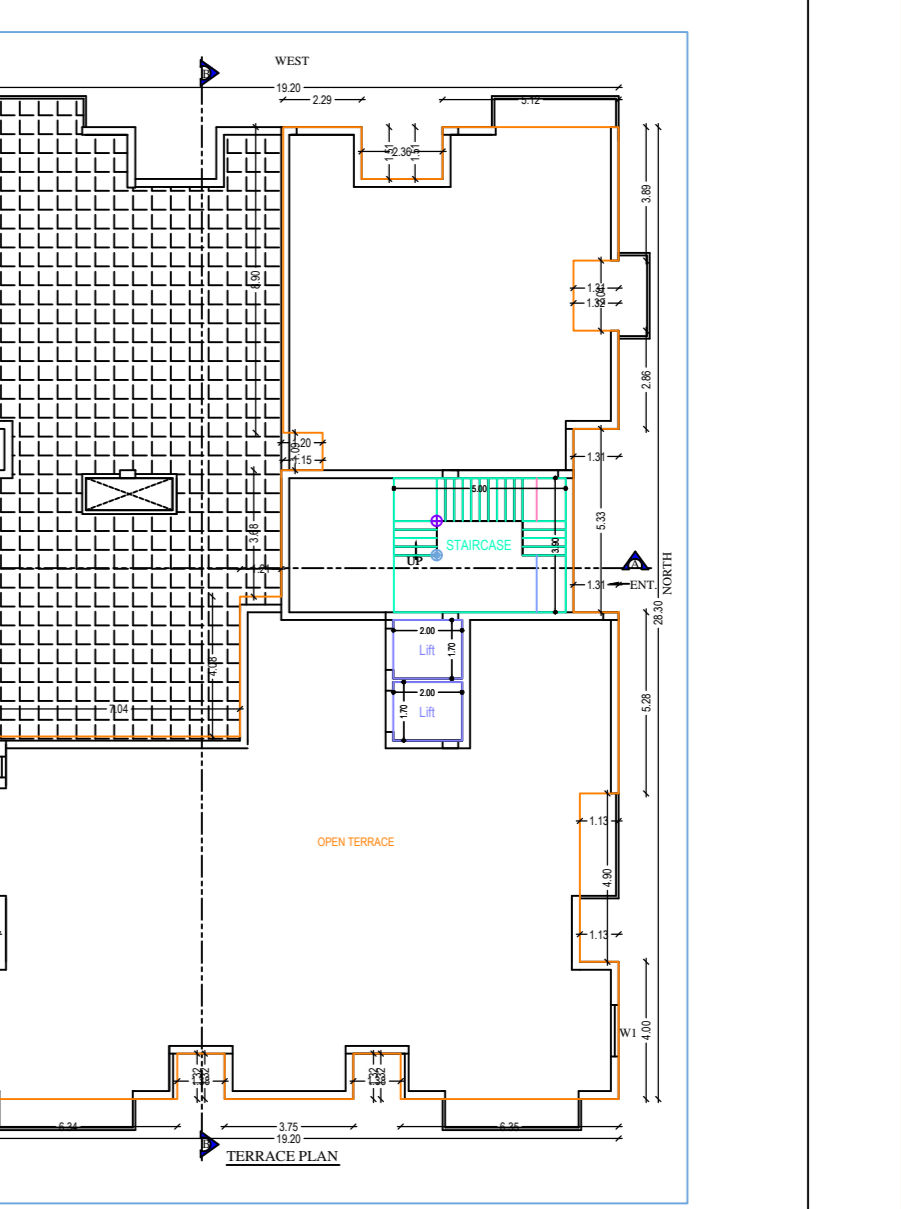
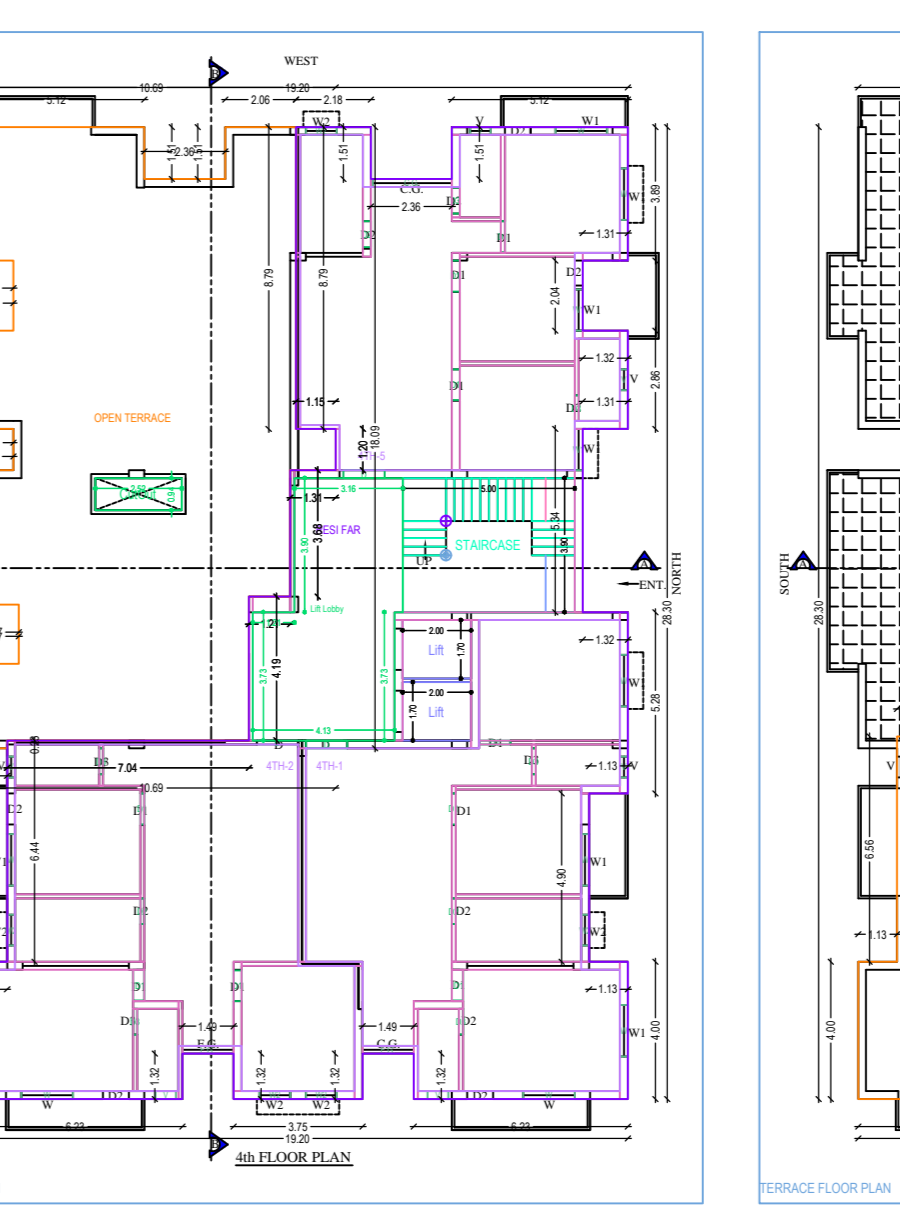
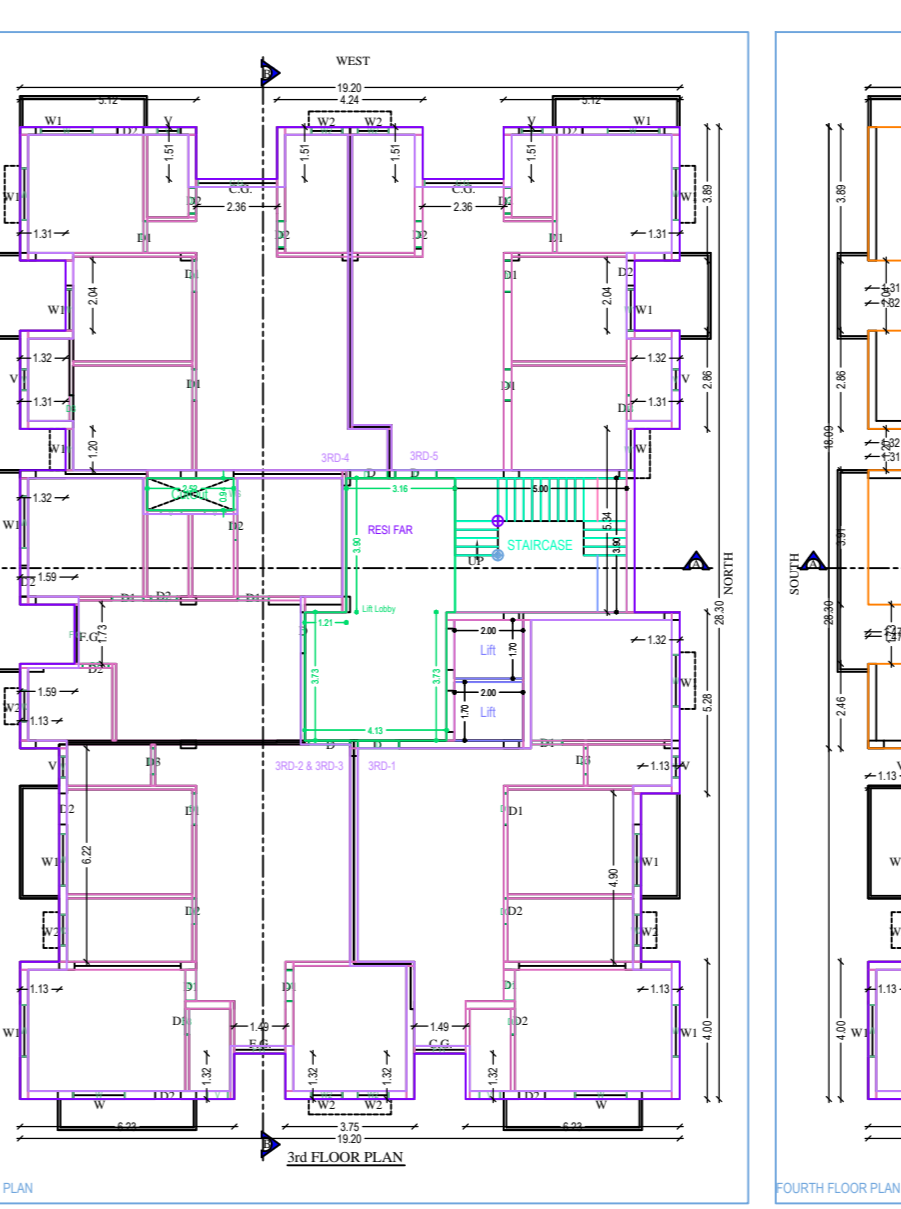
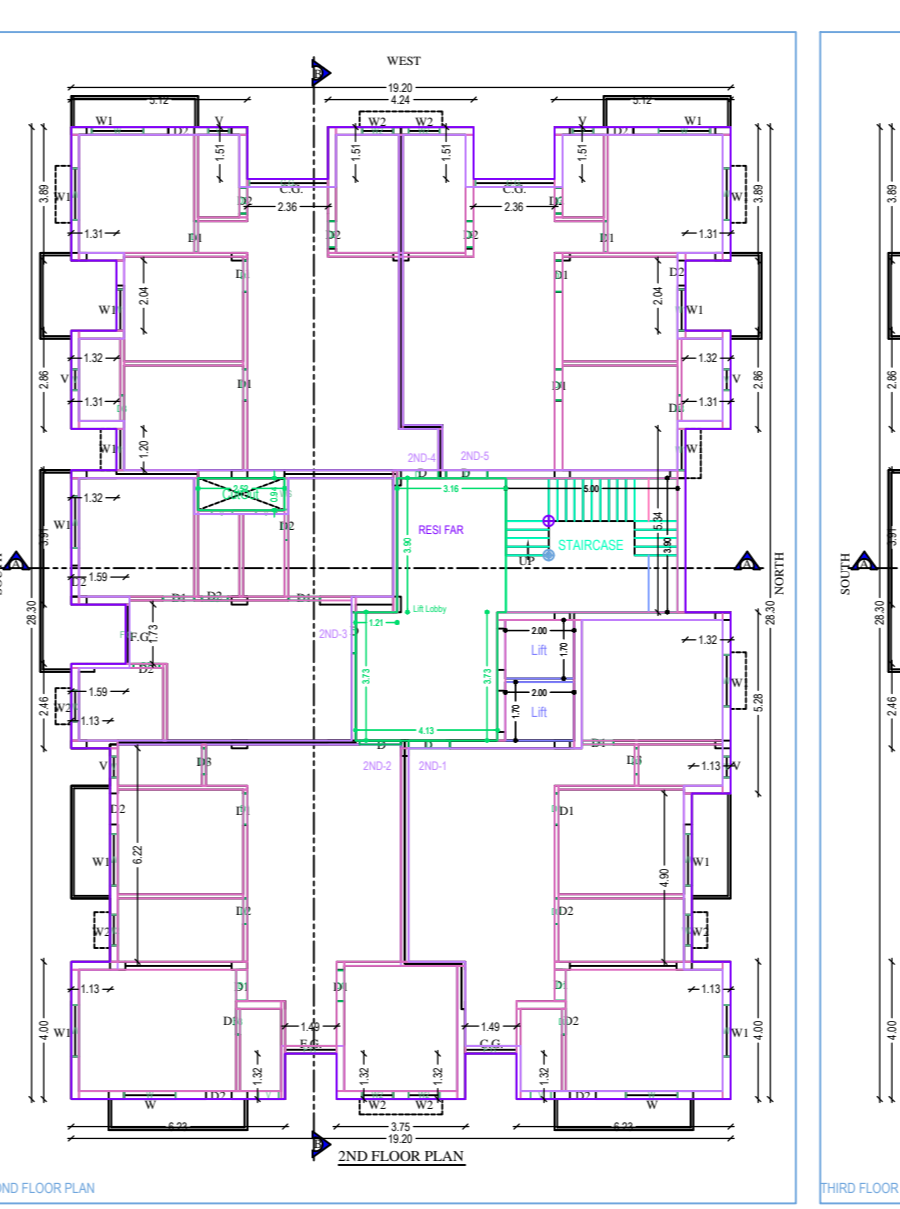
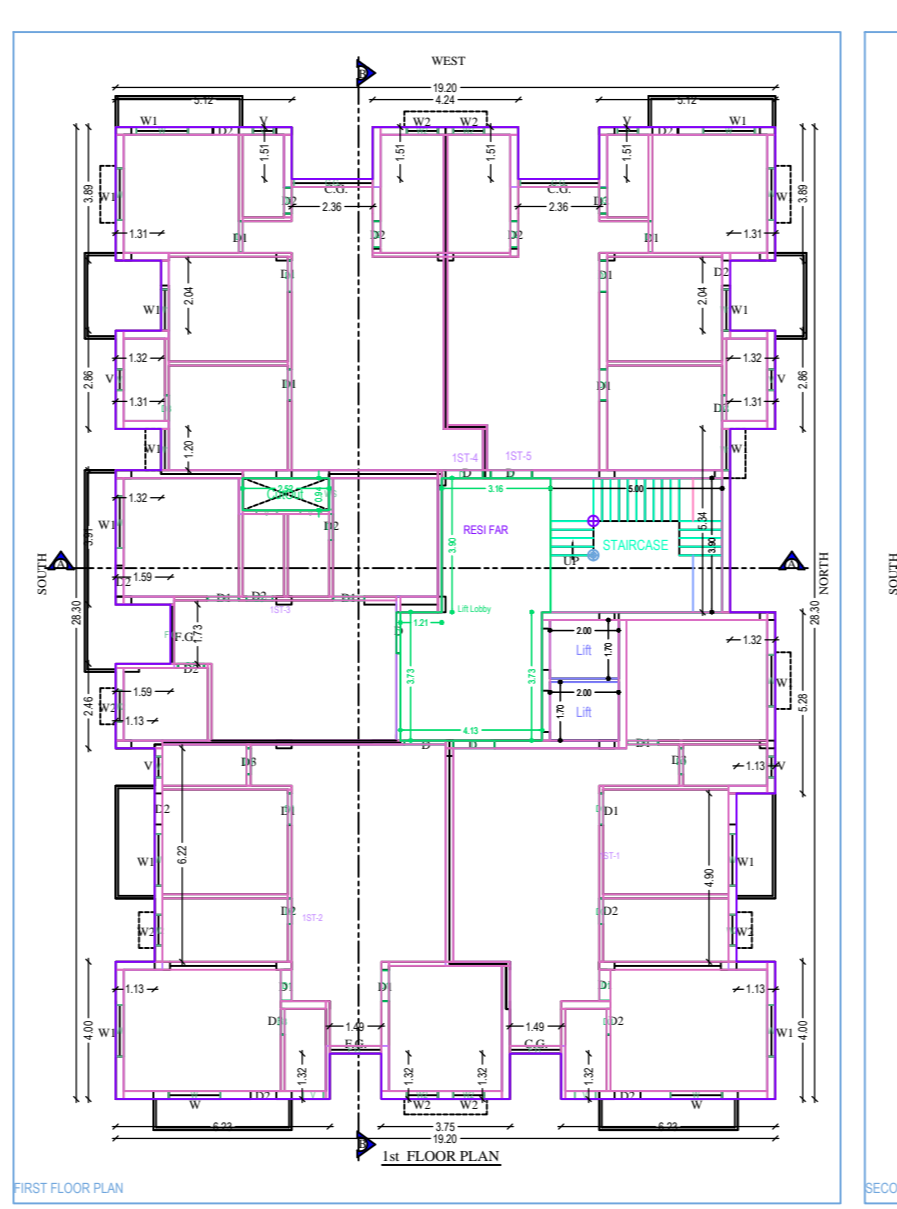
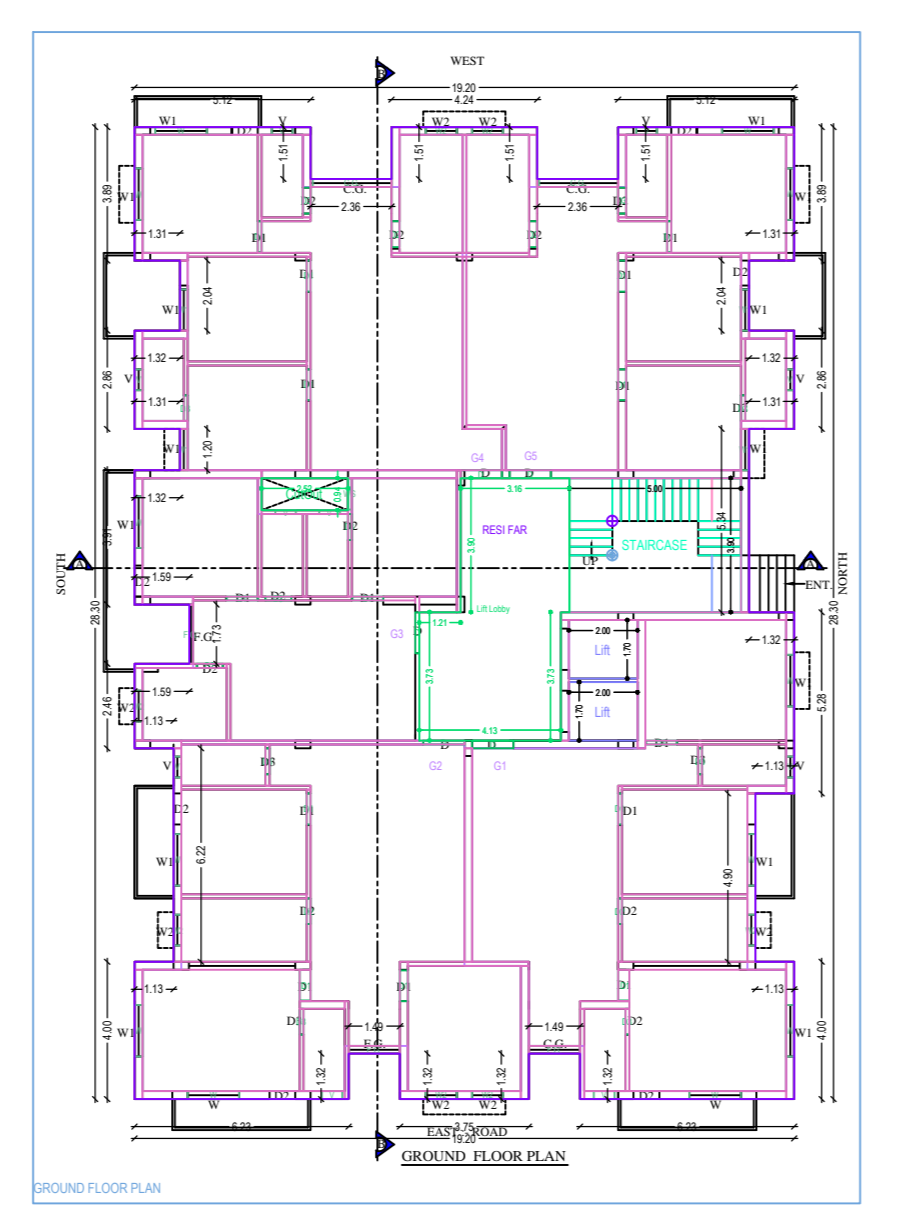
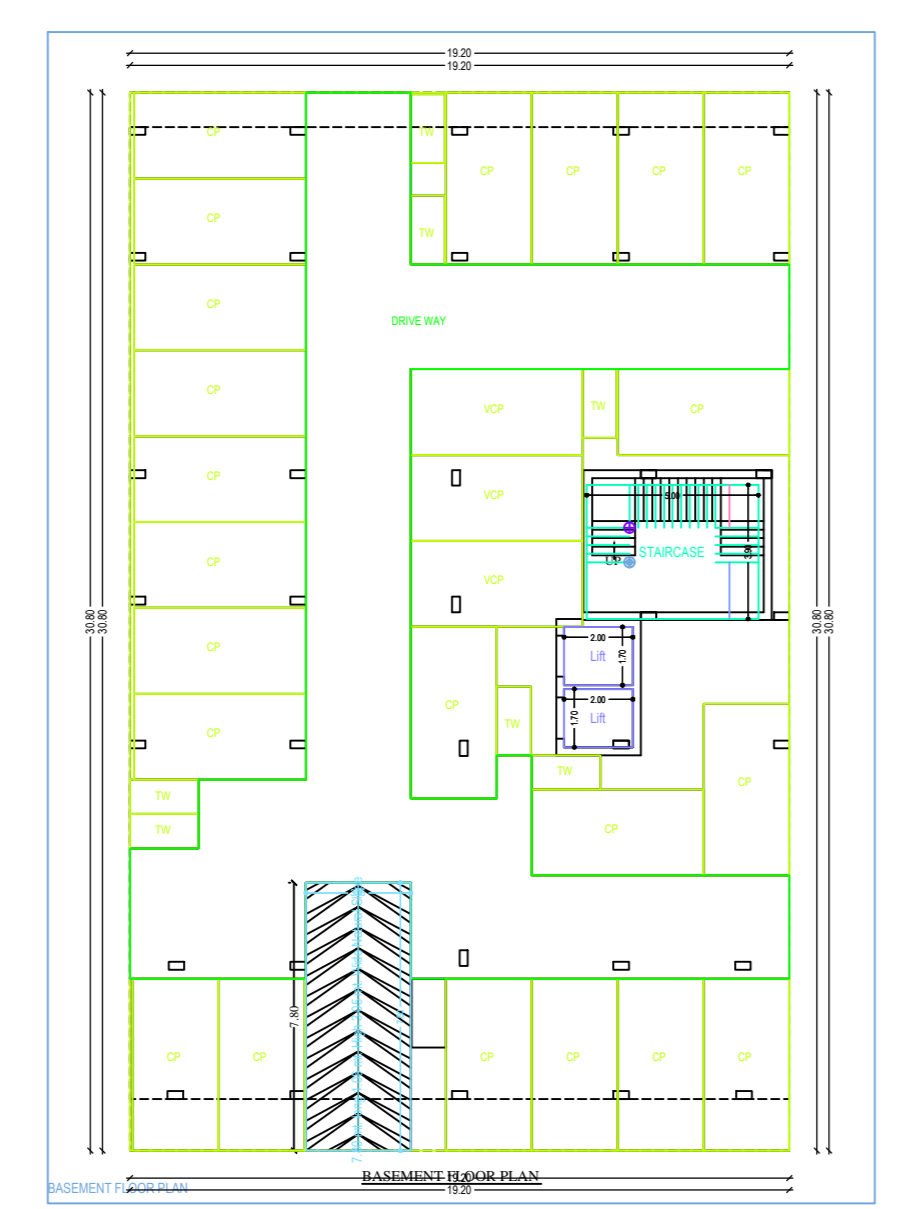
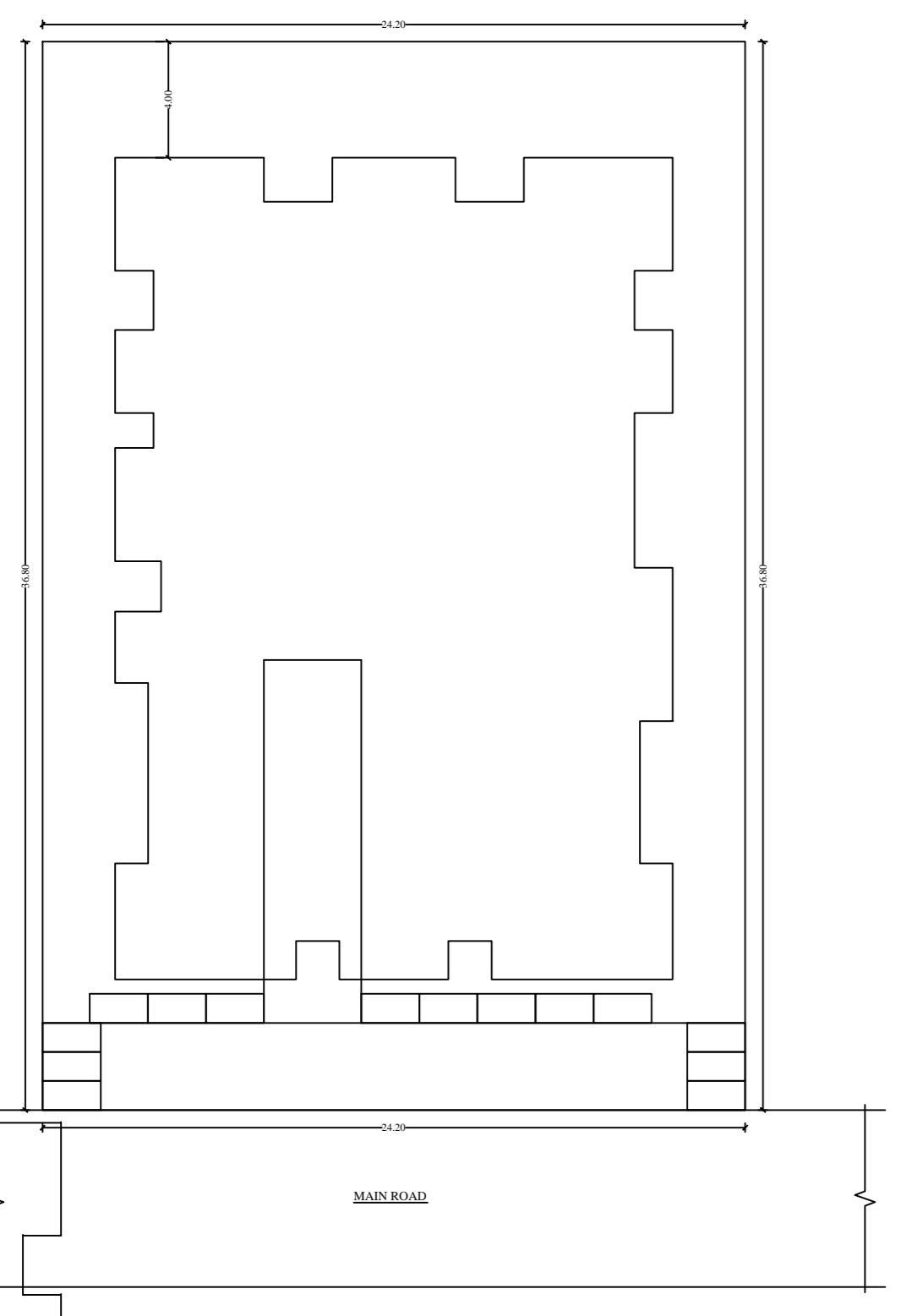
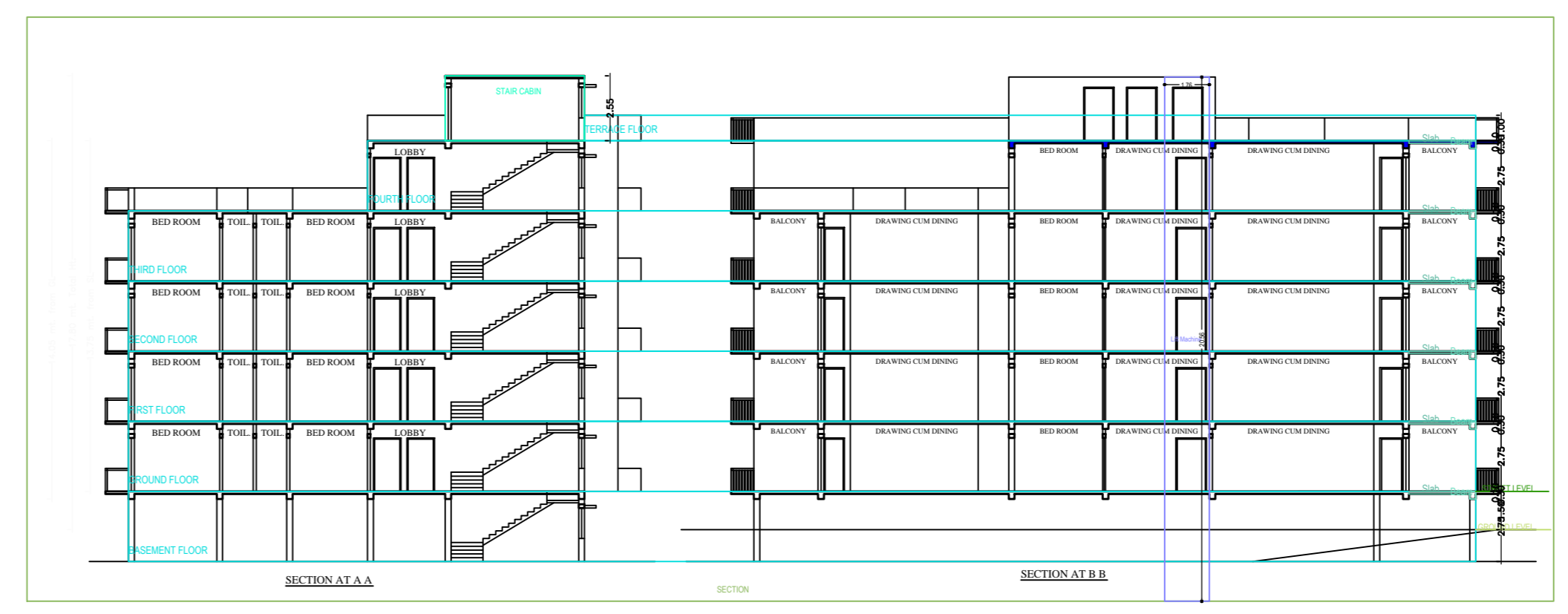
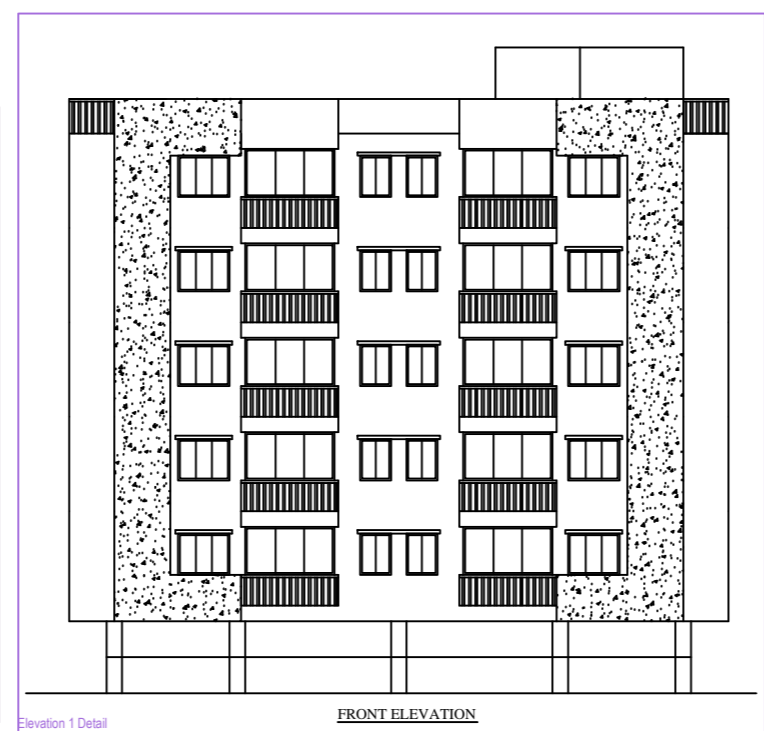
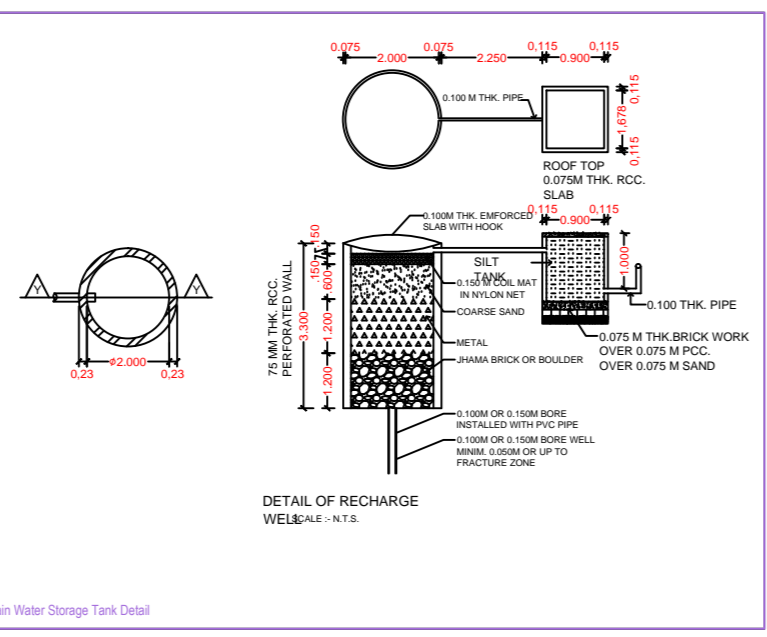
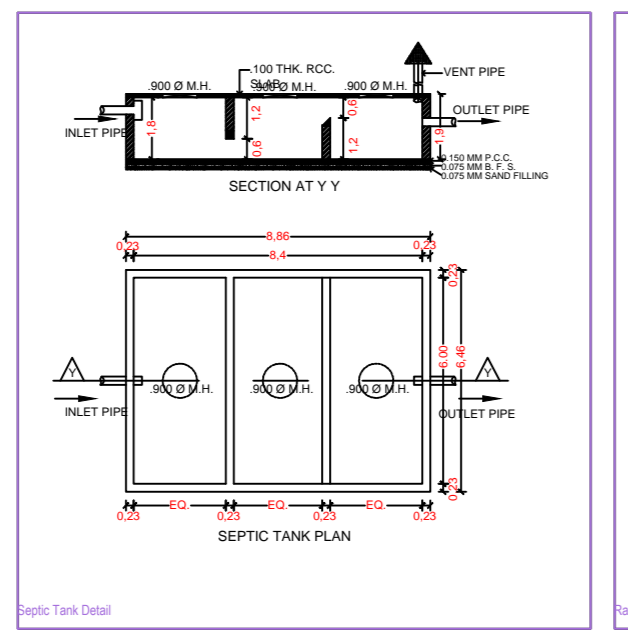
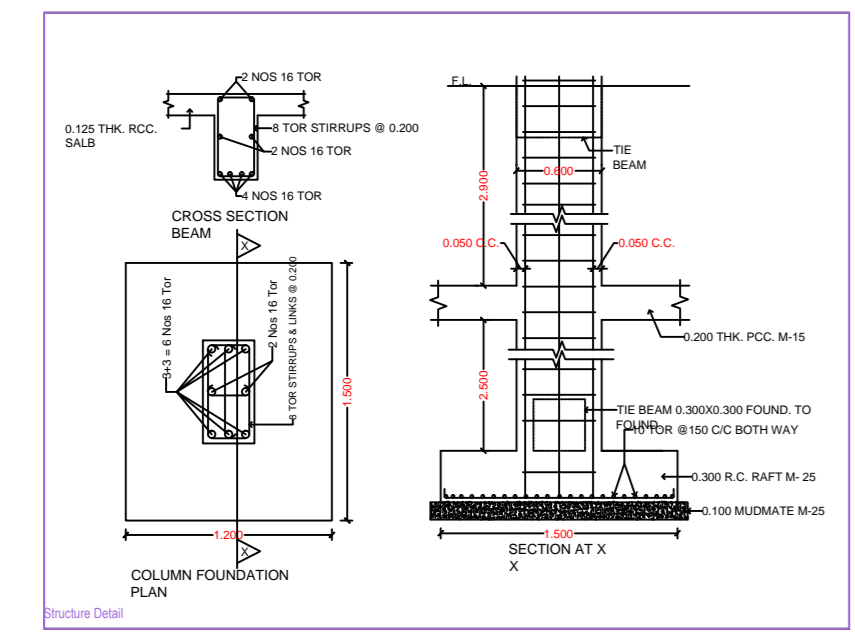

**Building Schedule**

Room No.	Area (sq. m)	Volume (cu. m)
1	100	1000
2	200	2000
3	300	3000
4	400	4000
5	500	5000
6	600	6000
7	700	7000
8	800	8000
9	900	9000
10	1000	10000
11	1100	11000
12	1200	12000
13	1300	13000
14	1400	14000
15	1500	15000
16	1600	16000
17	1700	17000
18	1800	18000
19	1900	19000
20	2000	20000
21	2100	21000
22	2200	22000
23	2300	23000
24	2400	24000
25	2500	25000
26	2600	26000
27	2700	27000
28	2800	28000
29	2900	29000
30	3000	30000
31	3100	31000
32	3200	32000
33	3300	33000
34	3400	34000
35	3500	35000
36	3600	36000
37	3700	37000
38	3800	38000
39	3900	39000
40	4000	40000
41	4100	41000
42	4200	42000
43	4300	43000
44	4400	44000
45	4500	45000
46	4600	46000
47	4700	47000
48	4800	48000
49	4900	49000
50	5000	50000
51	5100	51000
52	5200	52000
53	5300	53000
54	5400	54000
55	5500	55000
56	5600	56000
57	5700	57000
58	5800	58000
59	5900	59000
60	6000	60000
61	6100	61000
62	6200	62000
63	6300	63000
64	6400	64000
65	6500	65000
66	6600	66000
67	6700	67000
68	6800	68000
69	6900	69000
70	7000	70000
71	7100	71000
72	7200	72000
73	7300	73000
74	7400	74000
75	7500	75000
76	7600	76000
77	7700	77000
78	7800	78000
79	7900	79000
80	8000	80000
81	8100	81000
82	8200	82000
83	8300	83000
84	8400	84000
85	8500	85000
86	8600	86000
87	8700	87000
88	8800	88000
89	8900	89000
90	9000	90000
91	9100	91000
92	9200	92000
93	9300	93000
94	9400	94000
95	9500	95000
96	9600	96000
97	9700	97000
98	9800	98000
99	9900	99000
100	10000	100000