

Proposal Basic Information	
Proposal File No.	CMC/BP/0240/W02/2019
Owner Name	LAL BIHARI SINHA
Khata No	13
Plot No	595
Village Name	Chas
Use	Residential
SubUse	Bungalow/ Dwelling / Non Apartment

AREA STATEMENT CHAS MUNICIPAL CORPORATION		VERSION NO: 1.0.42
PROJECT DETAIL:		VERSION DATE: 29/04/2019
Region: JHARKHAND URBAN LOCAL BODIES	Plot Use: Residential	
District: BOKARO	Plot SubUse: Bungalow/ Dwelling / Non Apartment	
Authority: CHAS MUNICIPAL CORPORATION	PlotNearbyReligiousStructure: NA	
Inward_No: CMC/BP/0240/W02/2019	North: Plot No. - 593	
Application Type: General Proposal	South: Road Width - 4.57 m road	
Project Type: Building Permission	East: Plot No. - 594	
Nature of Development: New	West: Plot No. - kokila gope	
Location of Development Area: Old Area		
AREA DETAILS:		
AREA OF PLOT (Minimum)	(A)	SQ.MT. 282.22
NET AREA OF PLOT(Gross Plot Area - Deduction from Gross Plot area)	(A-Deductions)	282.22
Deduction for Balance Plot Area(from Gross Plot Area)		
Common Plot		28.74
Total		28.74
BALANCE AREA OF PLOT(Net Plot Area - Recreational/Amenity space)	(A-Deductions)	253.49
PLOT AREA FOR COVERAGE(Net Plot Area)	(A-Deductions)	282.22
Plot Area for FAR (Net Plot Area + Road/Widening Area)	(A-Deductions)	282.22
COVERAGE CHECK		
Permissible Coverage area (60.00 %)		169.33
Proposed Coverage Area (45.12 %)		127.33
Total Prop. Coverage Area (45.12 %)		127.33
Balance coverage area (14.88 %)		42.00
FAR CHECK		
Perm. FAR Area (1.50)		423.33
Total Perm. FAR area		423.33
Residential FAR		127.33
Proposed FAR Area		127.33
Total Proposed FAR Area		127.33
Consumed FAR (Factor)		0.45
Balance FAR Area		296.00
BUILT UP AREA CHECK		
Total Proposed BuiltUp Area		127.33
ARCHITECT (Regd)		RAVI KUMAR
ENGINEER (Regd)		
SUPERVISOR (Regd)		
OWNER (Regd)		LAL BIHARI SINHA
DEVELOPMENT AUTHORITY		LOCAL BODY

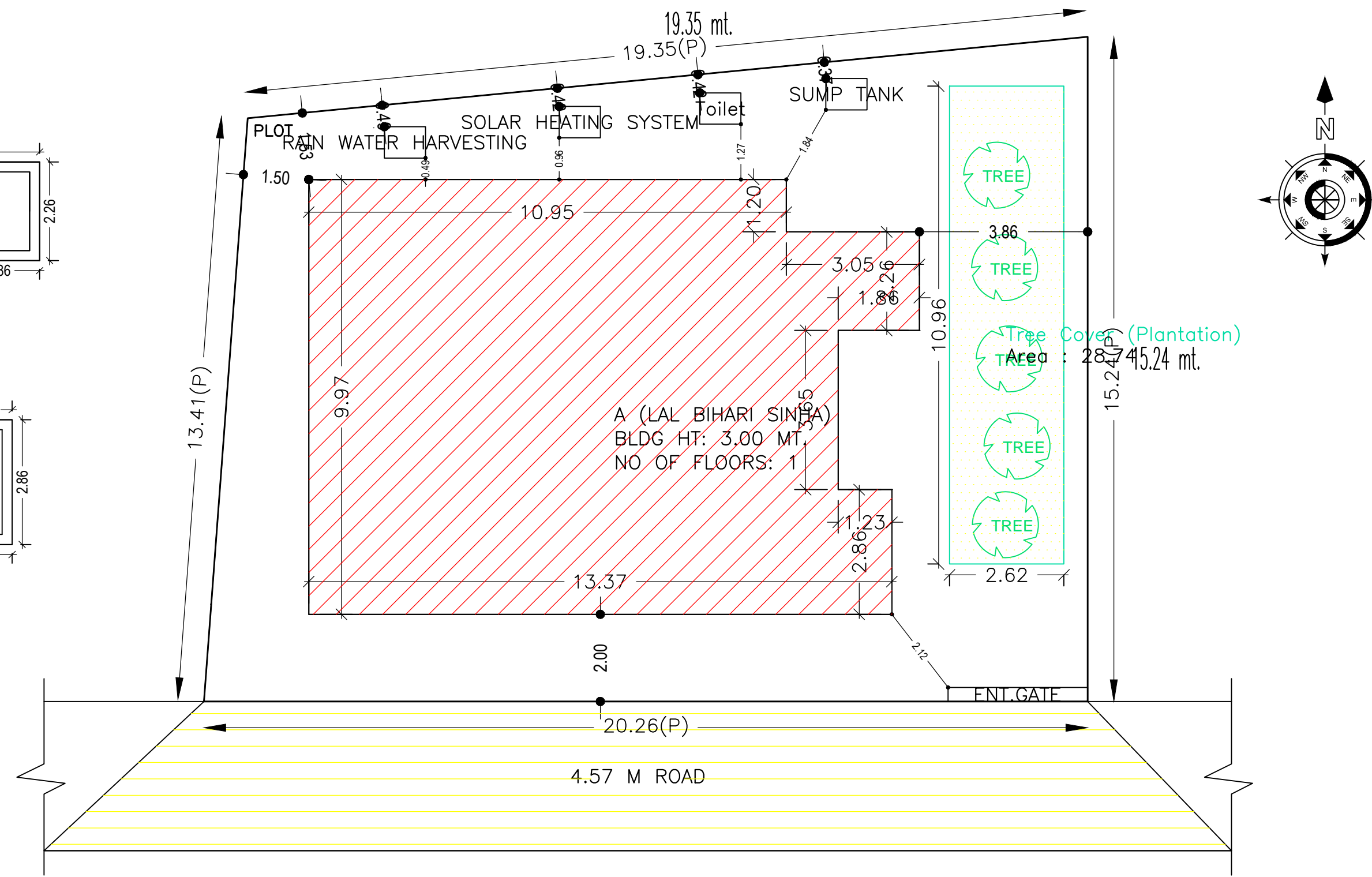
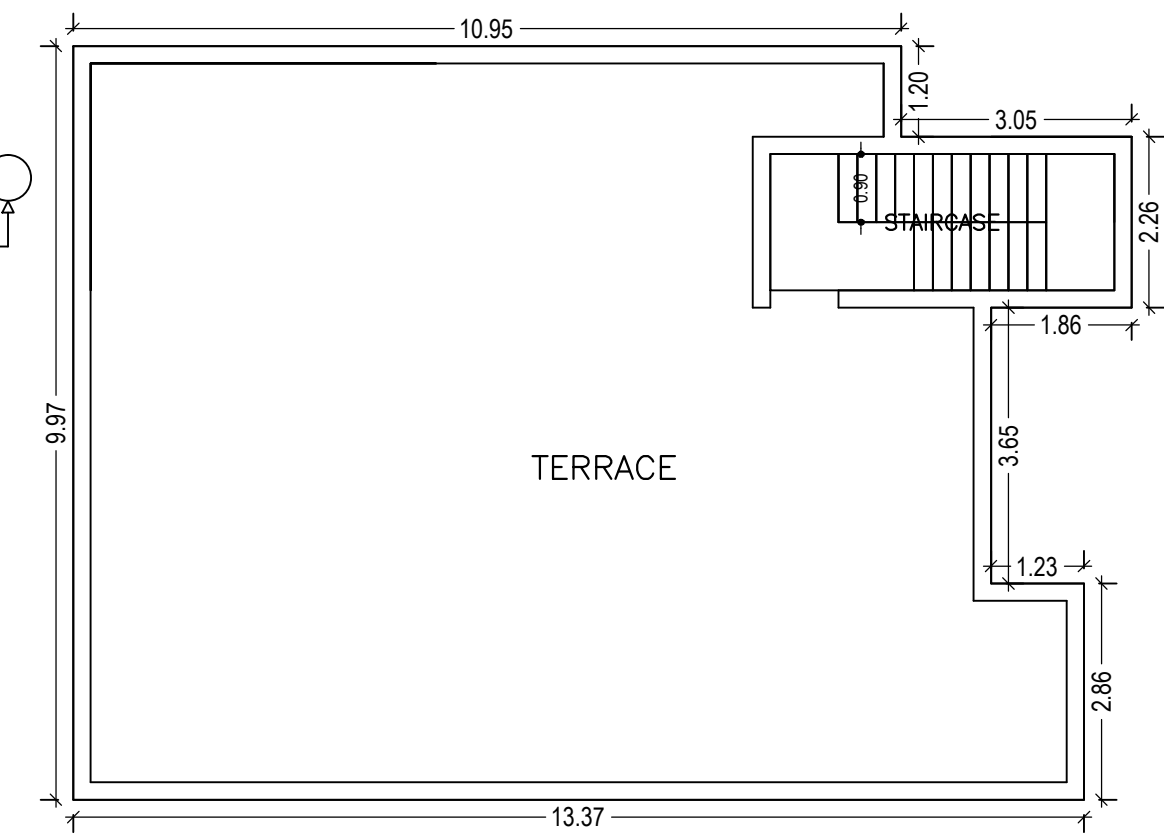
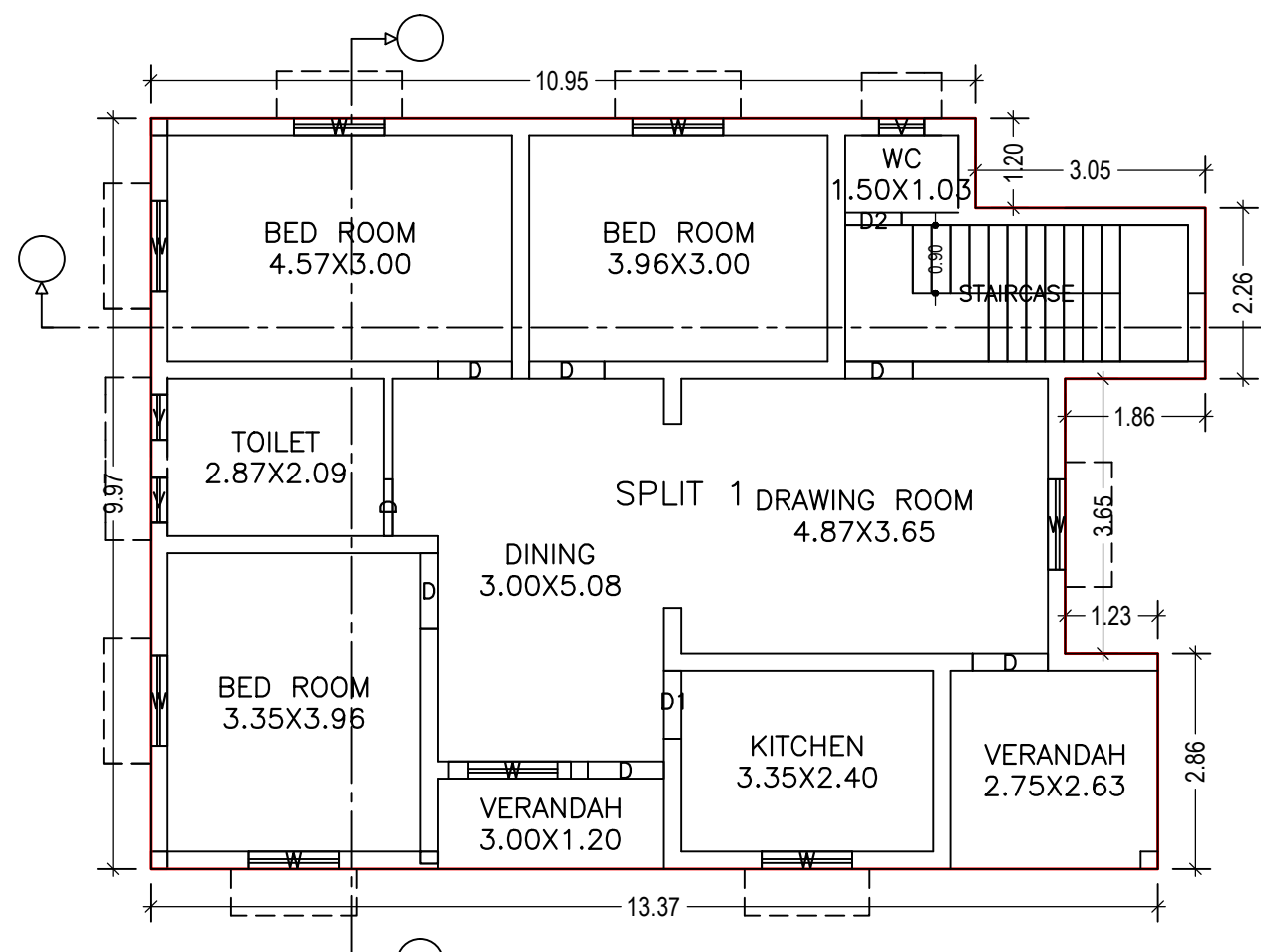
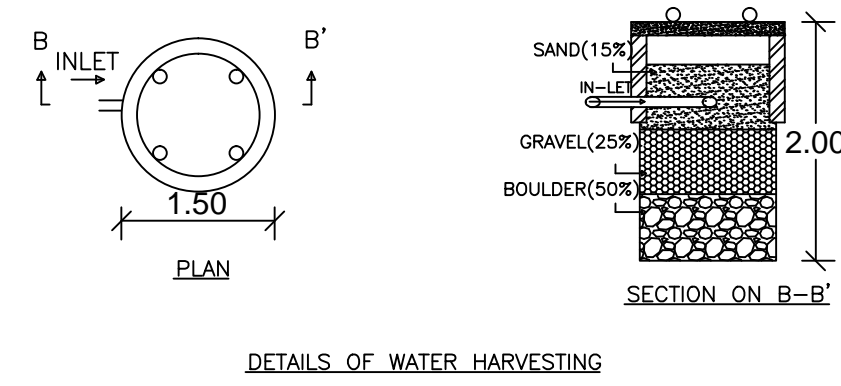
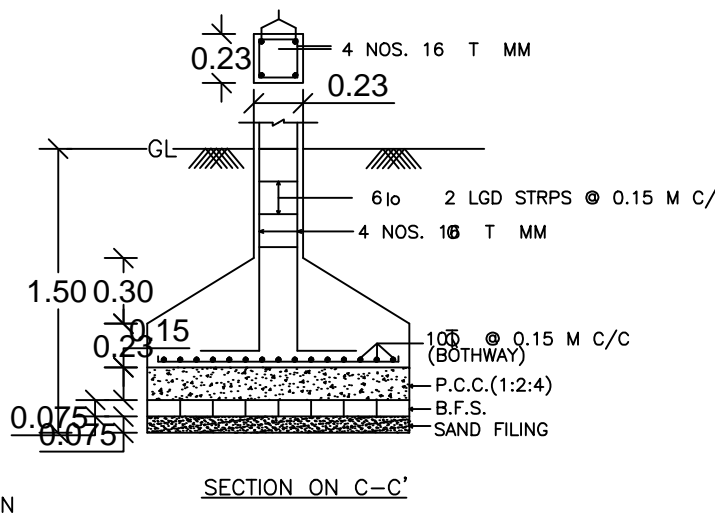
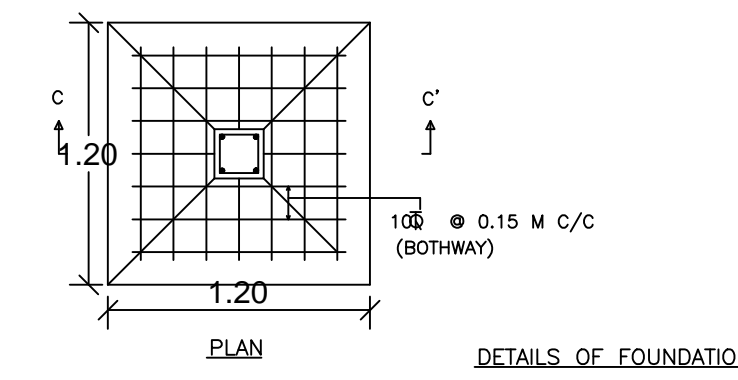
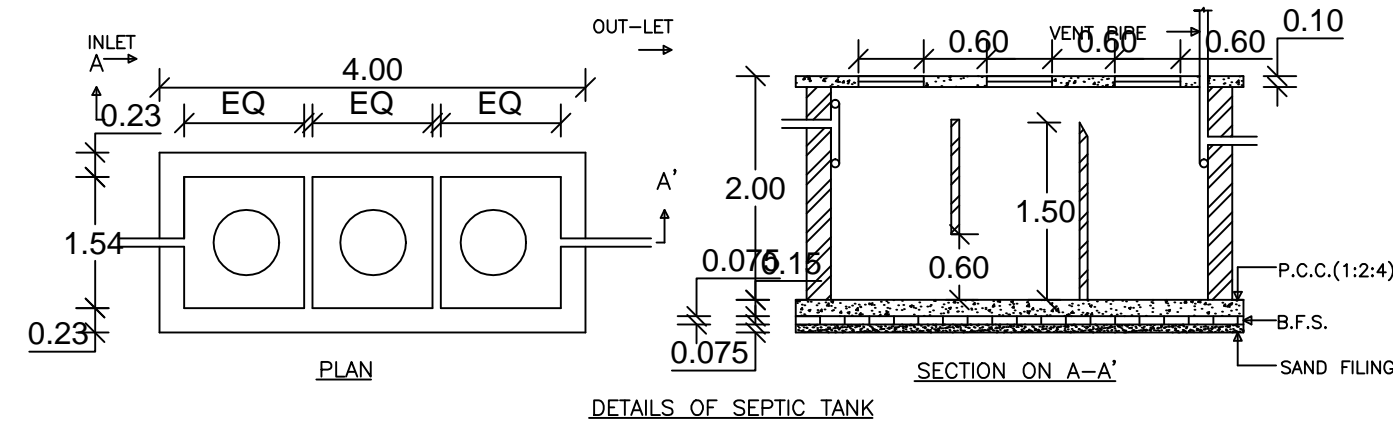

COLOR INDEX	
PLOT BOUNDARY	Black
ABUTTING ROAD	Green
PROPOSED CONSTRUCTION	Red
COMMON PLOT	Yellow
ROAD WIDENING AREA	Blue
EXISTING (To be retained)	Light Blue
EXISTING (To be demolished)	Light Yellow

SCHEDULE OF DOOR:				
BUILDING NAME	NAME	LENGTH	HEIGHT	NOS
A (LAL BIHARI SINHA)	D2	0.75	2.10	01
A (LAL BIHARI SINHA)	D	0.75	2.10	01
A (LAL BIHARI SINHA)	D1	0.90	2.10	01
A (LAL BIHARI SINHA)	D	0.90	2.10	01
A (LAL BIHARI SINHA)	D	0.99	2.10	01
A (LAL BIHARI SINHA)	D	1.00	2.10	04

SCHEDULE OF WINDOW/VENTILATION:				
BUILDING NAME	NAME	LENGTH	HEIGHT	NOS
A (LAL BIHARI SINHA)	v	0.60	1.20	03
A (LAL BIHARI SINHA)	w	1.20	1.20	07
A (LAL BIHARI SINHA)	w	1.64	1.20	01

Building :A (LAL BIHARI SINHA)					
Floor Name	Total Built Up Area (Sq.mt.)	Proposed FAR Area (Sq.mt.)	Total FAR Area (Sq.mt.)	Total Consumed Additional FAR Area (Sq.mt.)	Tnmt (No.)
Ground Floor	127.33	127.33	127.33	127.33	01
Terrace Floor	0.00	0.00	0.00	0.00	00
Total :	127.33	127.33	127.33	127.33	01
Total Number of Same Buildings :	1				
Total :	127.33	127.33	127.33	127.33	01

Buildingwise Floor FAR Details

Floor Name	Building Name		Total	
	Proposed Built Up Area (Sq.mt.)	Proposed FAR Area (Sq.mt.)	Total Proposed Built Up Area (Sq.mt.)	Total FAR Area (Sq.mt.)
Ground Floor	127.33	127.33	127.33	127.33
Terrace Floor	0.00	0.00	0.00	0.00
Total :	127.33	127.33	127.33	127.33

FAR & Tenement Details (Table 4c-1)

Building	No. of Same Bldg	Total Built Up Area (Sq.mt.)	Proposed FAR Area (Sq.mt.)	Total FAR Area (Sq.mt.)	Total Consumed Additional FAR Area (Sq.mt.)	Tnmt (No.)	UnitBUA Table for Building :A (LAL BIHARI SINHA)						
							FLOOR	Name	UnitBUA Type	UnitBUA Area	Carpet Area	No. of Rooms	No. of Tenement
A (LAL BIHARI SINHA)	1	127.33	127.33	127.33	127.33	01	GROUND FLOOR PLAN	SPLIT 1	FLAT	127.33	127.19	10	1
Grand Total :	1	127.33	127.33	127.33	127.33	01	Total:	-	-	127.33	127.19	10	1

LTP NAME AND SIGNATURE	STRUCTURAL ENG'S NAME AND SIGNATURE	BUILDER NAME AND SIGNATURE	DIGITAL SIGNATURE
RAVI KUMAR CMC/DFTM/0024/2017			