

Proposal Basic Information	
Proposal File No.	CMC/BP/0159/W07/2020
Owner Name	SHRI DALJEET SINGH
Khata No	623,620
Plot No	3297,3300
Village Name	Chas
Use	Residential
SubUse	Bungalow/ Dwelling / Non Apartment

AREA STATEMENT CHAS MUNICIPAL CORPORATION		VERSION NO. 1.0.50
		VERSION DATE: 16/10/2020
PROJECT DETAIL:		
Region: JHARKHAND URBAN LOCAL BODIES	Plot Use: Residential	
District: BOKARO	Plot SubUse: Bungalow/ Dwelling / Non Apartment	
Authority: CHAS MUNICIPAL CORPORATION	PlotNearbyReligiousStructure: NA	
Inward No: CMC/BP/0159/W07/2020	PlotSubPlot No: 3297,3300	
Application Type: General Proposal	North: CTS No. - SANT COLUMBUS SCHOOL	
Project Type: Building Permission	South: Road Width - 4.57	
Nature of Development: New	East: Road Width - 6.09	
Location of Development Area: Old Area	West: CTS No. - VIMAL YADAV KA MAKAN	
AREA DETAILS:		
AREA OF PLOT (Minimum)	(A)	SQ. MT. 185.53
NET AREA OF PLOT(Gross Plot Area - Deduction from Gross Plot area)	(A-Deductions)	185.53
Deduction for Balance Plot Area(from Gross Plot Area)		
Common Plot		11.90
Total		11.90
BALANCE AREA OF PLOT(Net Plot Area - Recreational/Amenity space)	(A-Deductions)	173.63
PLOT AREA FOR COVERAGE(Net Plot Area)	(A-Deductions)	185.53
Plot Area for FAR (Net Plot Area + Road Widening Area)	(A-Deductions)	185.53
COVERAGE CHECK		
Permissible Coverage area (70.00 %)		129.87
Proposed Coverage Area (63.26 %)		117.36
Total Prop. Coverage Area (63.26 %)		117.36
Balance coverage area (6.74 %)		12.51
FAR CHECK		
Perm. FAR Area (1.50)		278.29
Total Perm. FAR area		278.29
Residential FAR		234.72
Proposed FAR Area		234.72
Total Proposed FAR Area		234.72
Consumed FAR (Factor)		1.27
Balance FAR Area		43.57
BUILT UP AREA CHECK		
Total Proposed BuiltUp Area		234.72
ARCHITECT (Regd) SUBHASH NARHARRAO NETRAGAONKAR		
ENGINEER (Regd)		
SUPERVISOR (Regd)		
OWNER (Regd) SHRI DALJEET SINGH		
DEVELOPMENT AUTHORITY		LOCAL BODY

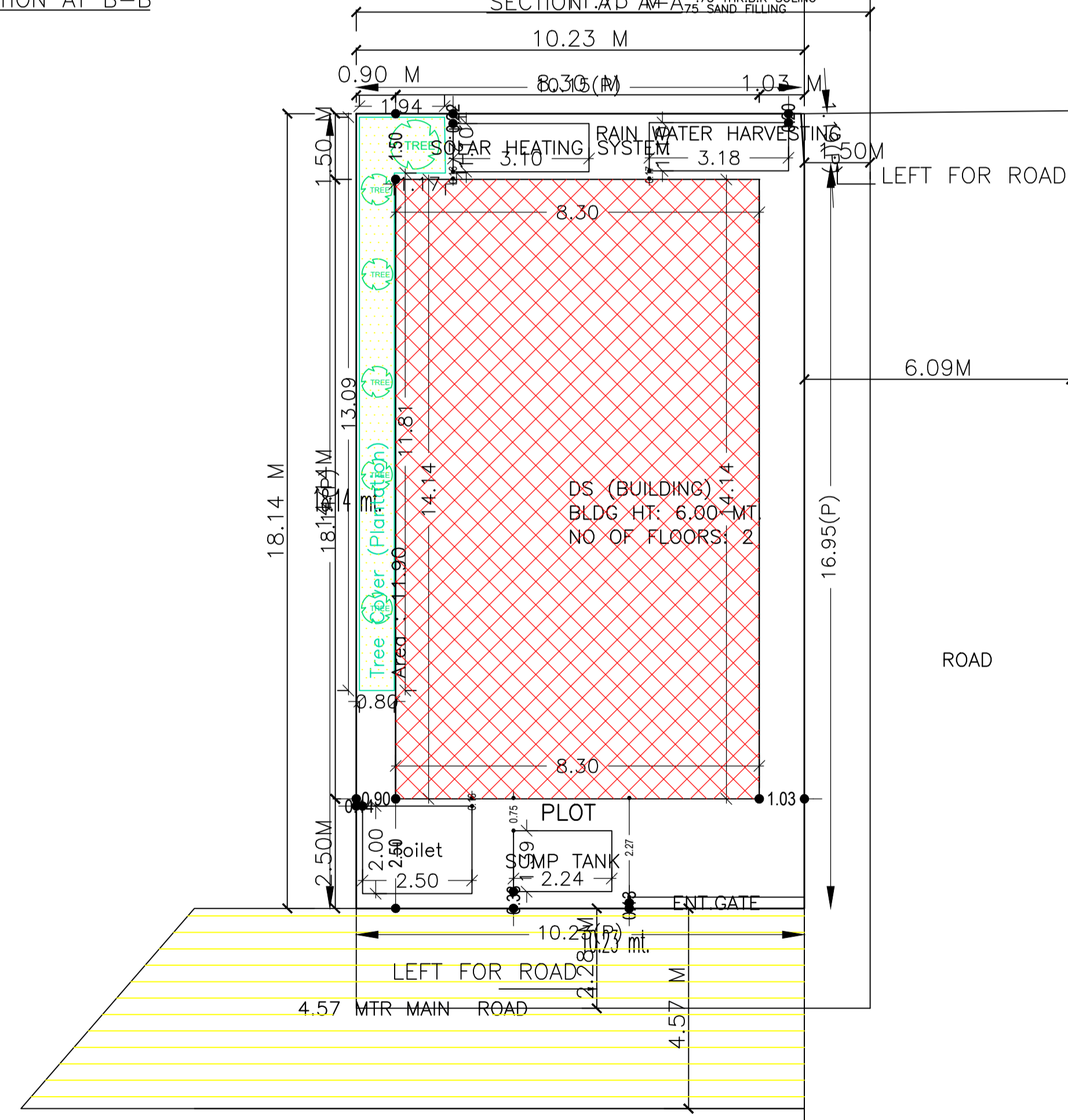
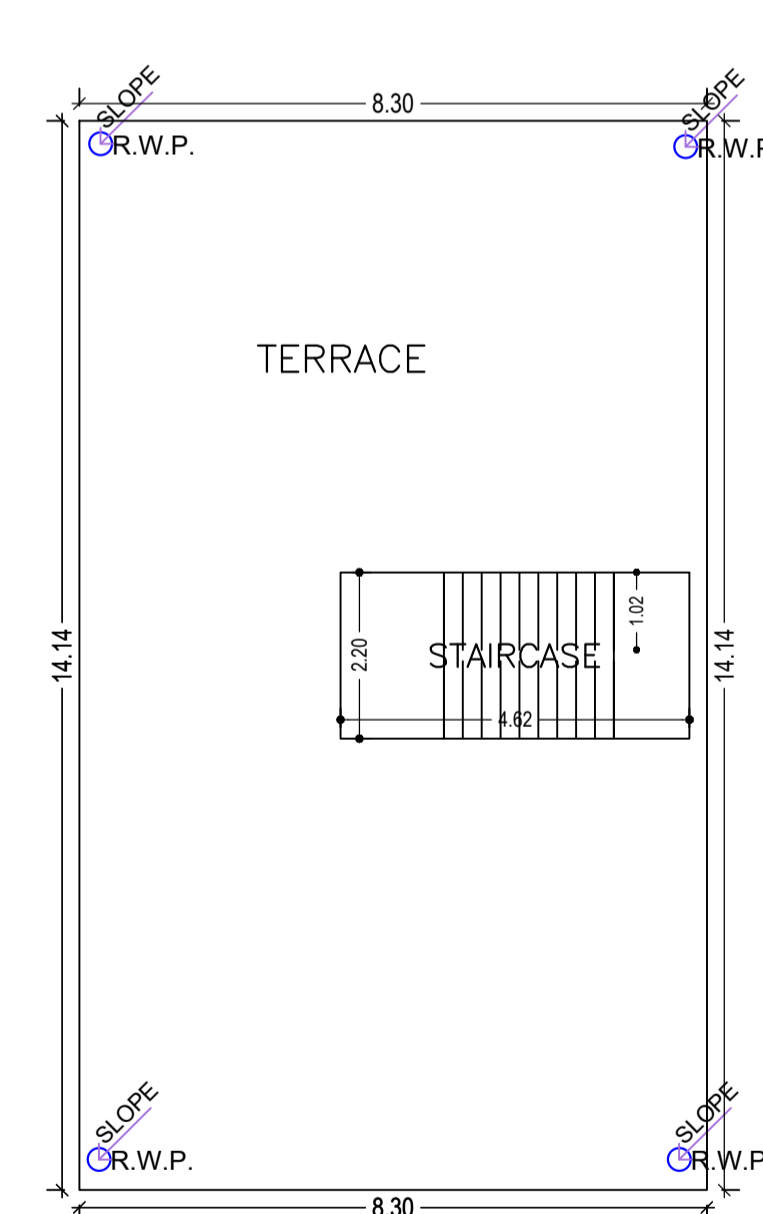
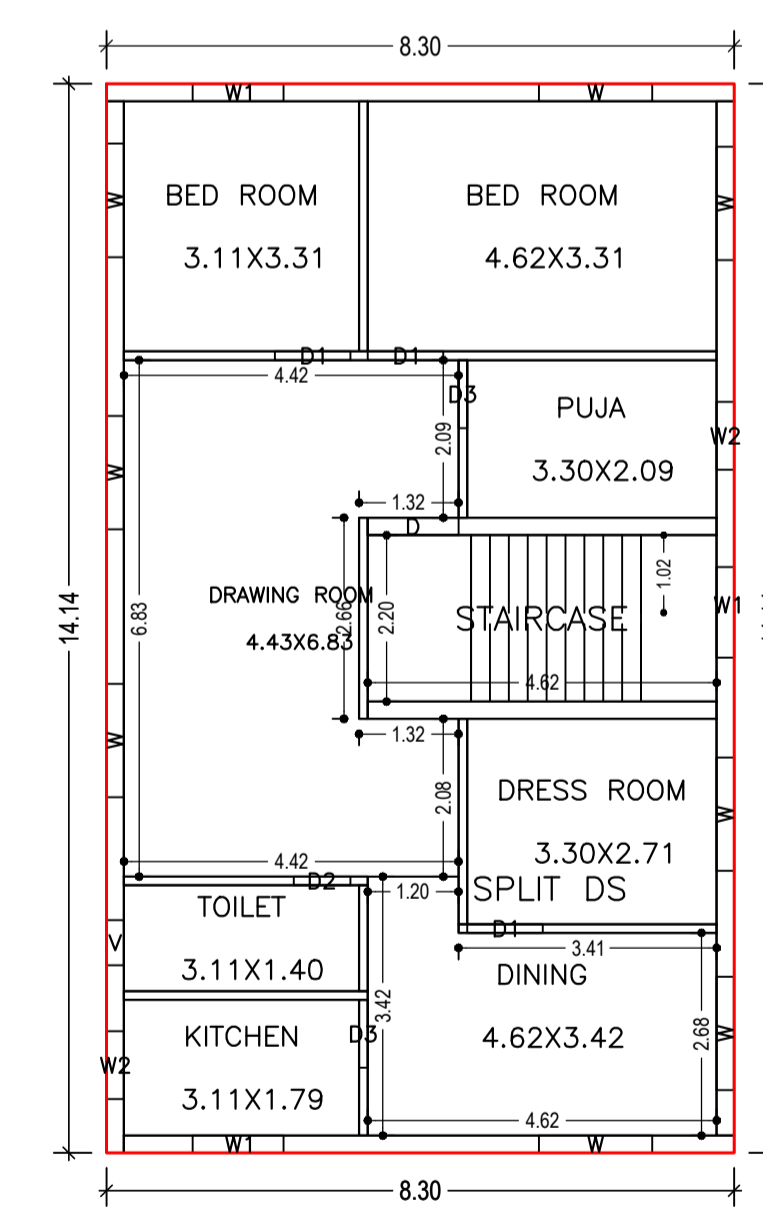
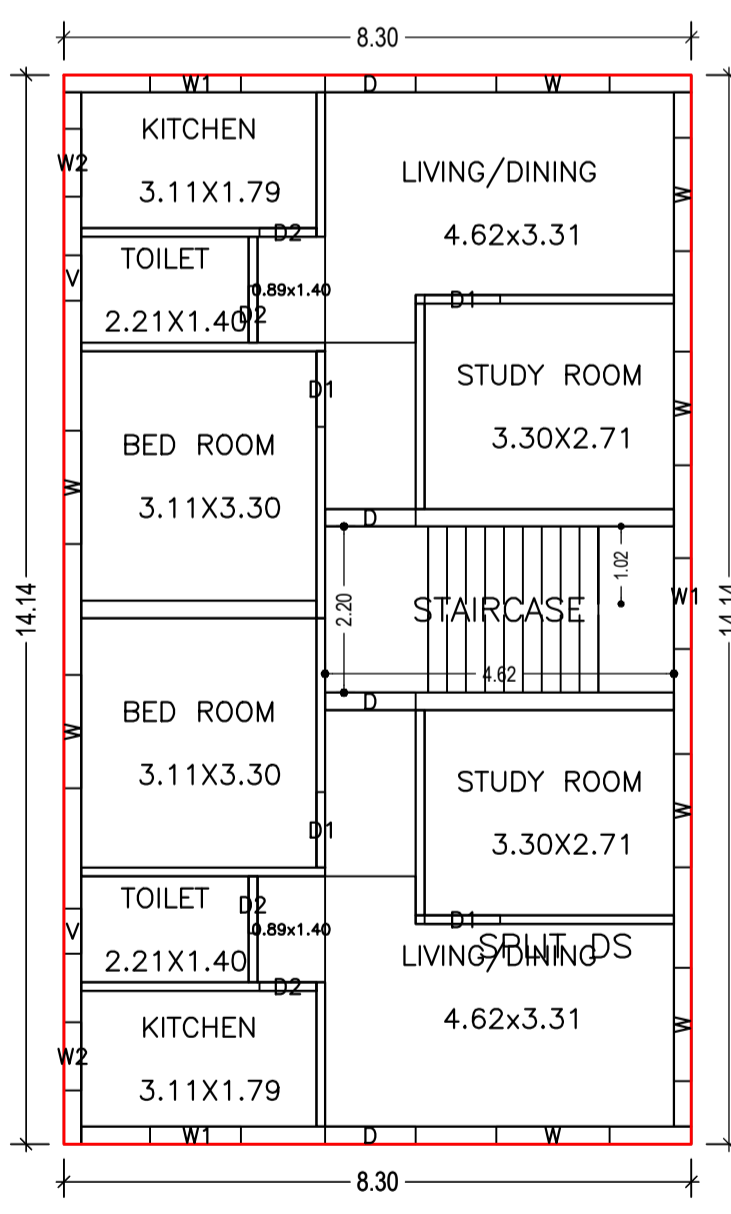
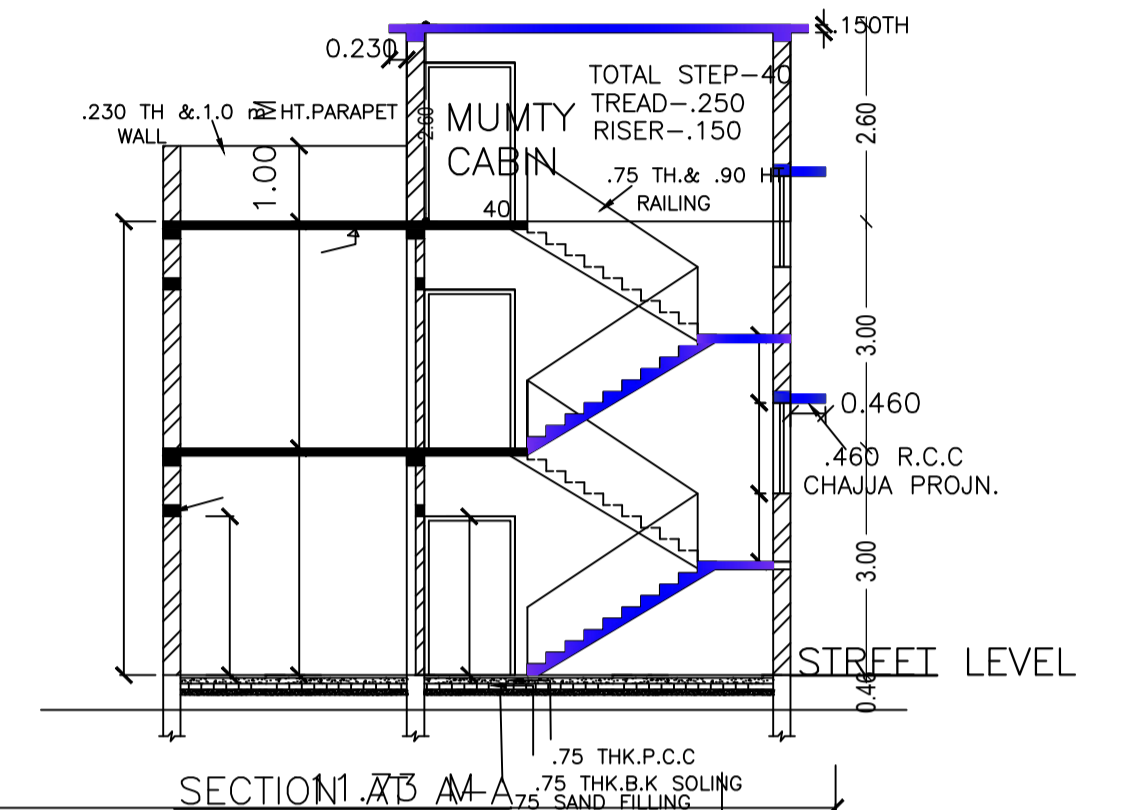
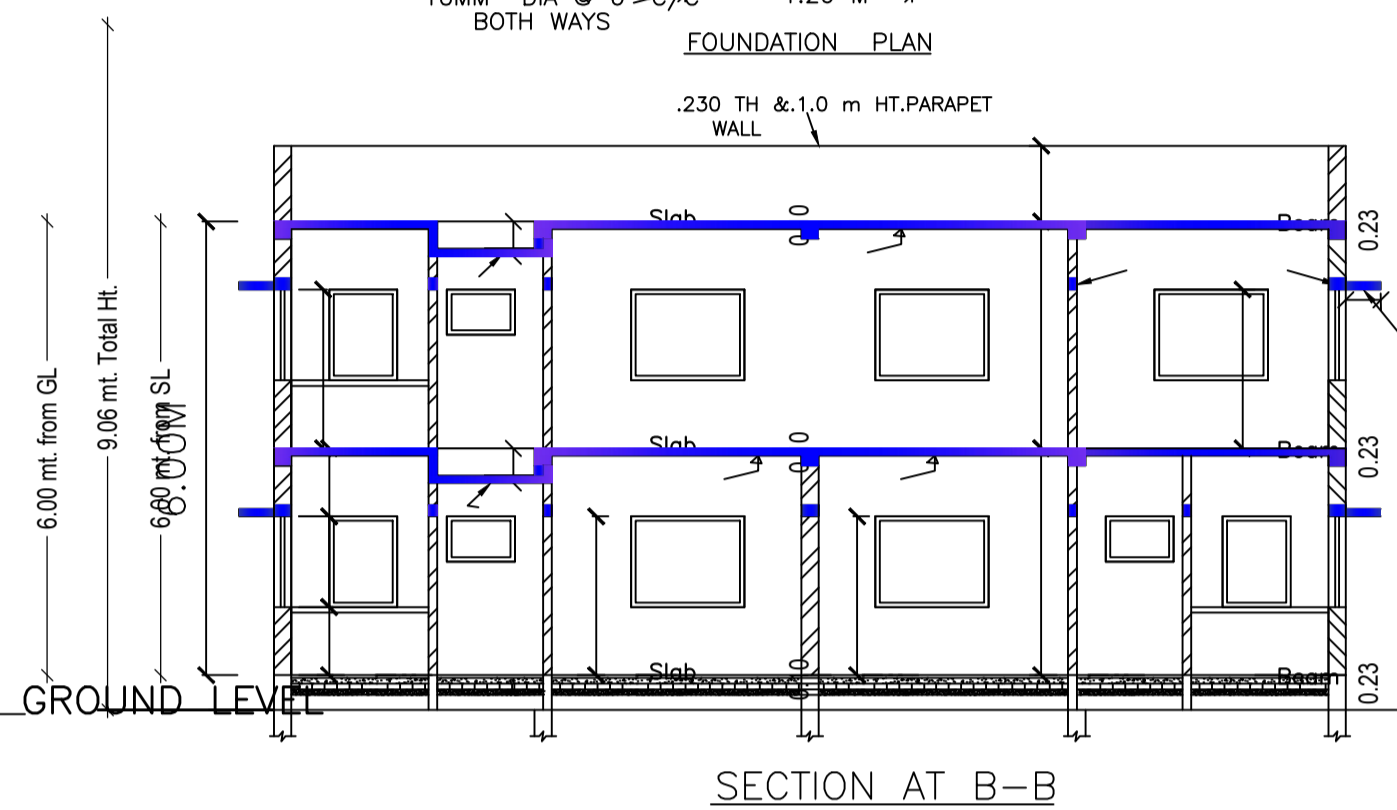

SCHEDULE OF DOOR:

BUILDING NAME	NAME	LENGTH	HEIGHT	NOS
DS (BUILDING)	D2	0.75	2.10	05
DS (BUILDING)	D3	0.90	2.10	02
DS (BUILDING)	D1	1.00	2.10	07
DS (BUILDING)	D	1.20	2.10	03

SCHEDULE OF WINDOW/VENTILATION:

BUILDING NAME	NAME	LENGTH	HEIGHT	NOS
DS (BUILDING)	V	0.60	0.90	03
DS (BUILDING)	W2	0.90	1.20	04
DS (BUILDING)	W1	1.20	1.20	06
DS (BUILDING)	W	1.50	1.20	16

Buildingwise Floor FAR Details

Floor Name	Building Name DS (BUILDING)		Total	
	Proposed Built Up Area (Sq.mt.)	Proposed FAR Area (Sq.mt.)	Total Proposed Built Up Area (Sq.mt.)	Total FAR Area (Sq.mt.)
Ground Floor	117.36	117.36	117.36	117.36
First Floor	117.36	117.36	117.36	117.36
Terrace Floor	0.00	0.00	0.00	0.00
Total	234.72	234.72	234.72	234.72

FAR & Tenement Details (Table 4c-1)

Building	No. of Same Bldg	Total Built Up Area (Sq.mt.)	Proposed FAR Area (Sq.mt.) Res.	Total FAR Area (Sq.mt.)	Total Consumed Additional FAR Area (Sq.mt.)	Trmt (No.)
DS (BUILDING)	1	234.72	234.72	234.72	234.72	01
Grand Total	1	234.72	234.72	234.72	234.72	01

Building USE/SUBUSE Details

Building Name	Building Use	Building SubUse	Building Structure
DS (BUILDING)	Residential	Bungalow/ Dwelling / Non Apartment	Non-Highrise

LTP NAME AND SIGNATURE	STRUCTURAL ENG'S NAME AND SIGNATURE	BUILDER NAME AND SIGNATURE	DIGITAL SIGNATURE
SUBHASH NARHARRAO NETRAGAONKAR CMC/ARC/0014/2018			

Building :DS (BUILDING)

Floor Name	Total Built Up Area (Sq.mt.)	Proposed FAR Area (Sq.mt.) Res.	Total FAR Area (Sq.mt.)	Total Consumed Additional FAR Area (Sq.mt.)	Trmt (No.)
Ground Floor	117.36	117.36	117.36	117.36	01
First Floor	117.36	117.36	117.36	117.36	00
Terrace Floor	0.00	0.00	0.00	0.00	00
Total	234.72	234.72	234.72	234.72	01
Total Number of Same Buildings	1				
Total :	234.72	234.72	234.72	234.72	01

UnitBUA Table for Building :DS (BUILDING)

FLOOR	Name	UnitBUA Type	UnitBUA Area	Carpet Area	No. of Rooms	No. of Tenement
GROUND FLOOR PLAN	SPLIT DS	FLAT	189.34	181.66	10	1
FIRST FLOOR PLAN	SPLIT DS	FLAT	0.00	0.00	8	0
Total:	-	-	189.34	181.66	18	1

