

Proposal Basic Information

Proposal File No.	CMC/BP/0235/W02/2020
Owner Name	1.VINOD KUMAR RAVI 2. REETA RANA
Khata No	172
Plot No	773
Village Name	Chas
Use	Residential
SubUse	Bungalow/ Dwelling / Non Apartment

AREA STATEMENT OMAS	VERSION NO. 1.0.0.0
MUNICIPAL CORPORATION	VERSION DATE: 16/10/2020
PROJECT DETAIL	
Region: PROPOSED URBAN	Plot Use: Residential
LOCAL BODIES:	Plot SubUse: Bungalow/ Dwelling / Non Apartment
District: BIKANER	Authority: KARNAL MUNICIPAL CORPORATION
Project No: CMC/BP/0235/W02/2020	Plot No: 773
Applicant Name: VINOD KUMAR RAVI 2. REETA RANA	North Road Width: 9.14
Project Type: Building Permission	South Plot No: 773
Nature of Development: New	East Road Width: 6.09
Location of Development Area: Old	West Survey No.: KAMALA PD 34/ARMA
AREA OF PLOT (Minimum)	432.17
NET AREA OF PLOT (Gross Plot Area - Deduction from Gross Plot Area)	432.17
Deduction for Balance Floor Area from Gross Plot Area	52.36
Common Plot Area	52.36
BALANCE AREA OF PLOT (Net Plot Area - Deductions)	382.15
Plot Area for Coverage (Net Plot Area - Deductions)	432.17
Plot Area for FAR (Net Plot Area - Deductions)	432.17
COVERAGE CHECK	
Permissible Coverage Area (80.00%)	305.74
Proposed Coverage Area (82.23%)	305.74
Total Proposed Coverage Area (82.23%)	305.74
Balance Coverage Area (10.37%)	39.39
FAR CHECK	
Plot FAR Area (2.50)	1082.00
Total FAR Area	1082.00
Residential FAR	1082.00
Proposed FAR Area	1082.00
Consumed FAR (Factor)	1082.00
Balance FAR Area	0.00
BUILT UP AREA CHECK	
Total Proposed Built-up Area	1282.25
ARCHITECT (Regd)	Nirmal Kumar Sharma
ENGINEER (Regd)	VINOD KUMAR RAVI 2. REETA RANA
SUPERVISOR (Regd)	
OWNER (Regd)	
DEVELOPMENT AUTHORITY	LOCAL BODY

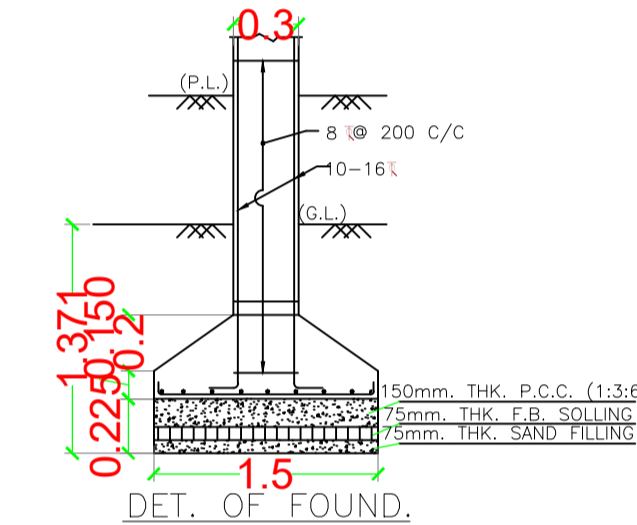
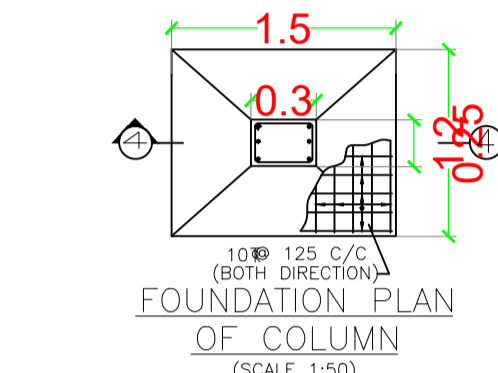
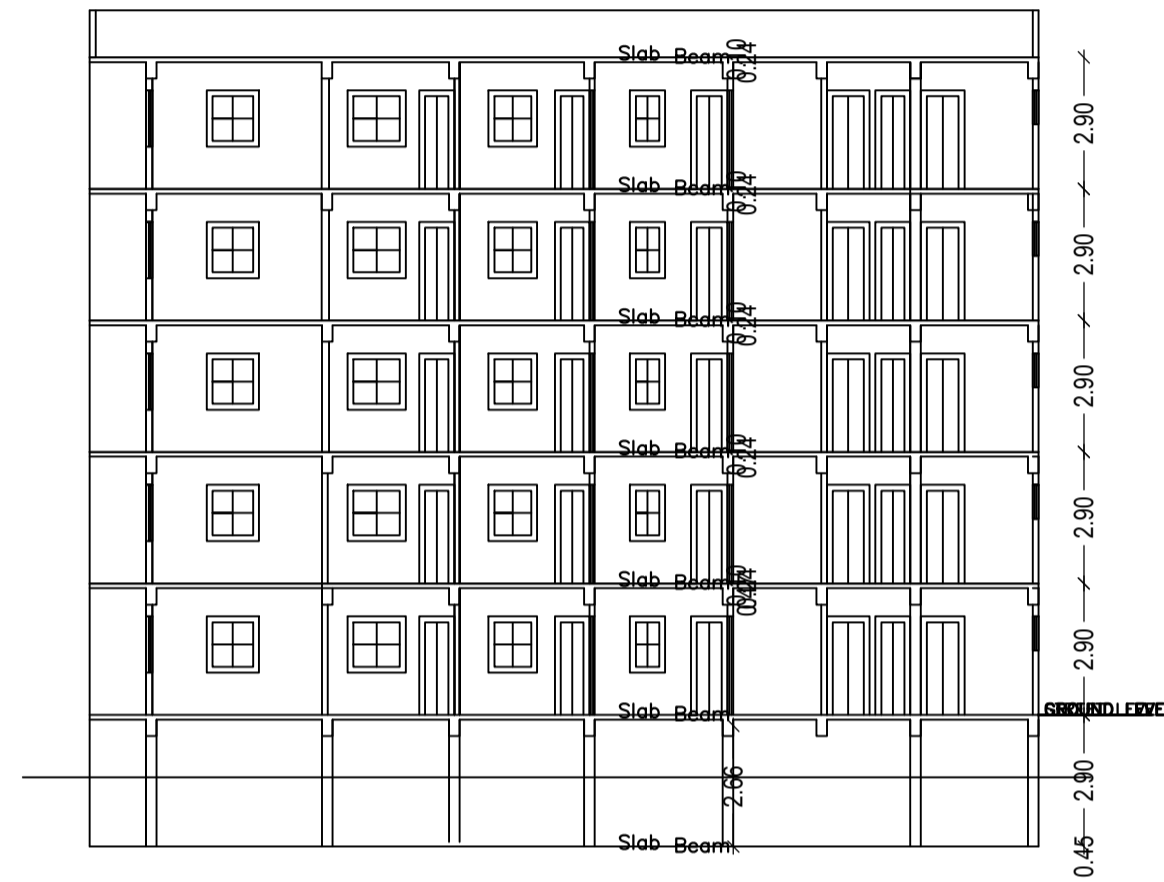
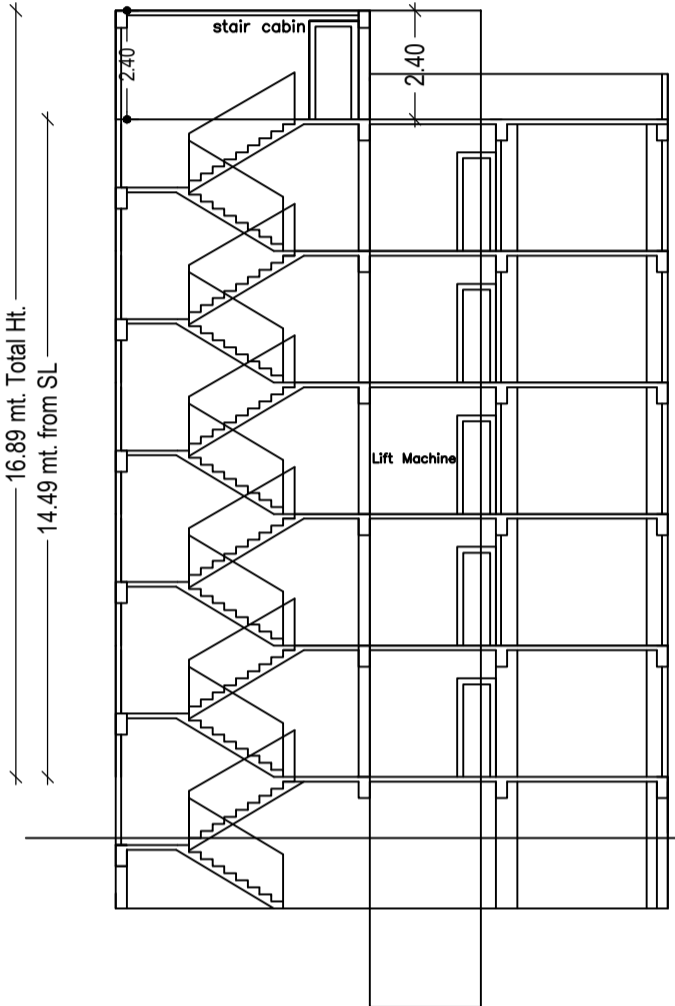
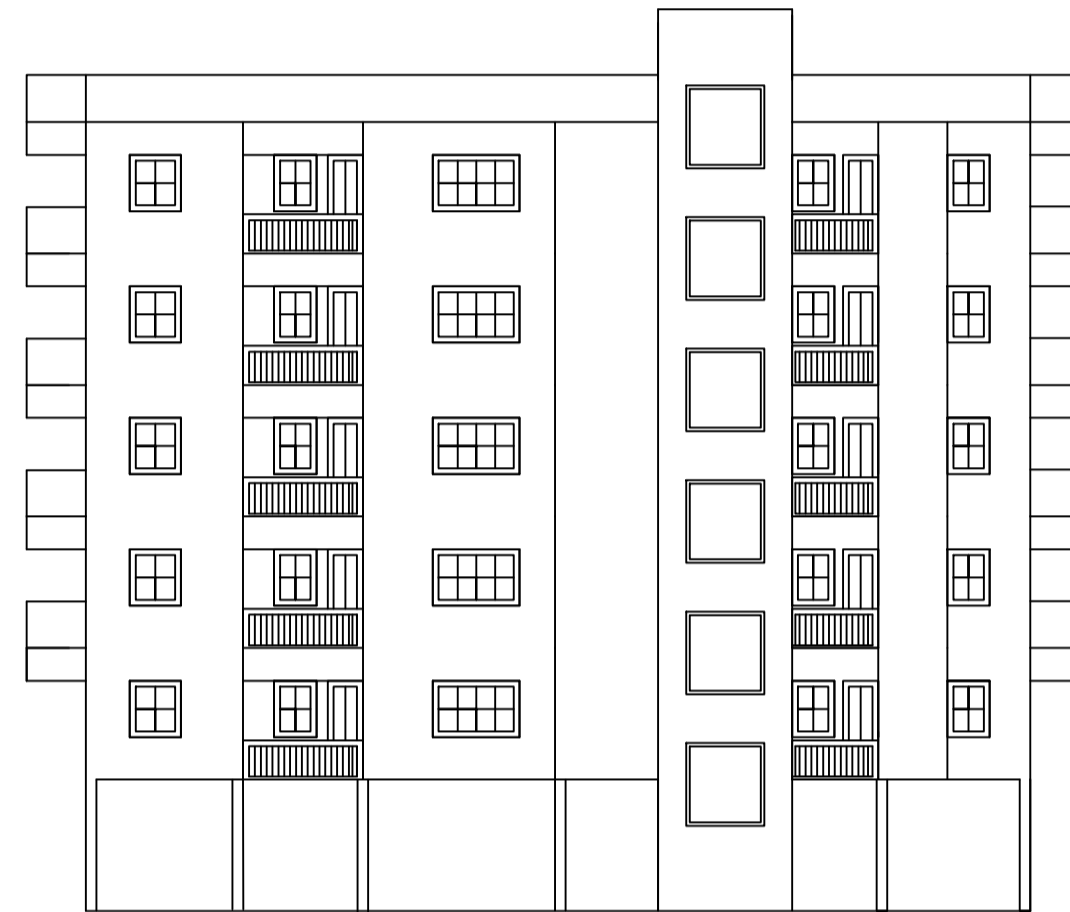
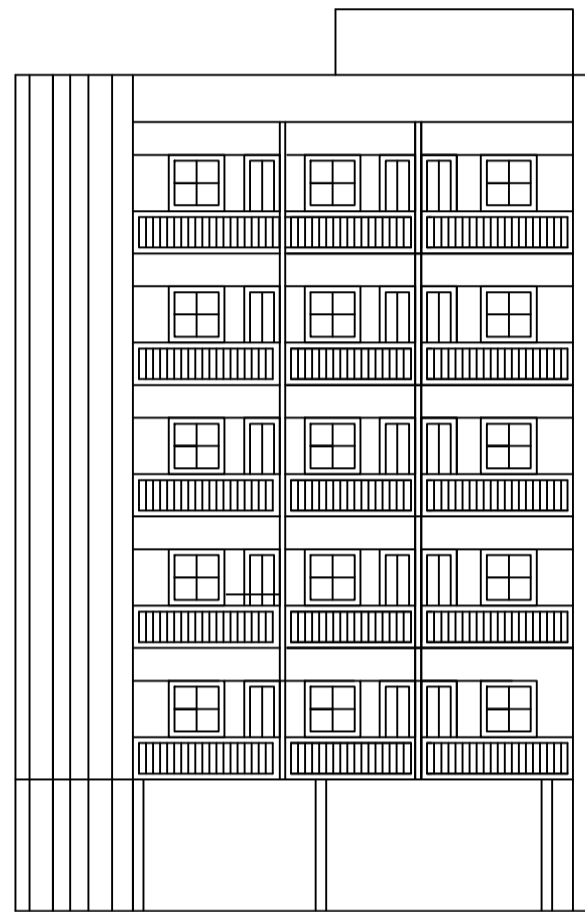
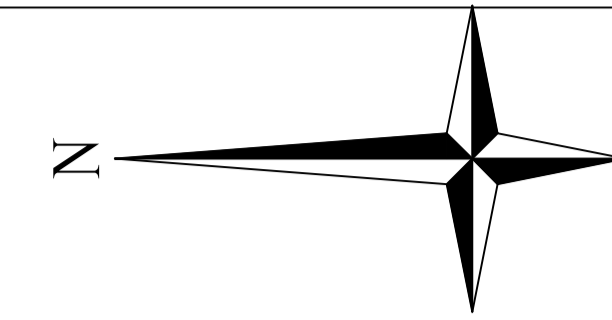
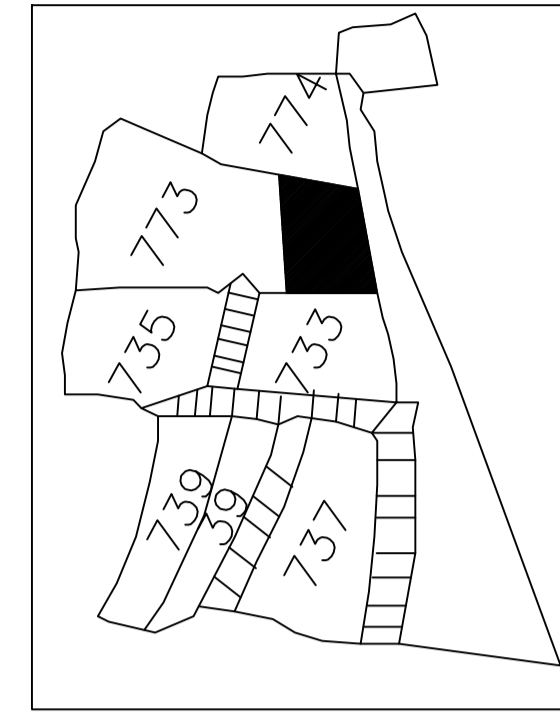
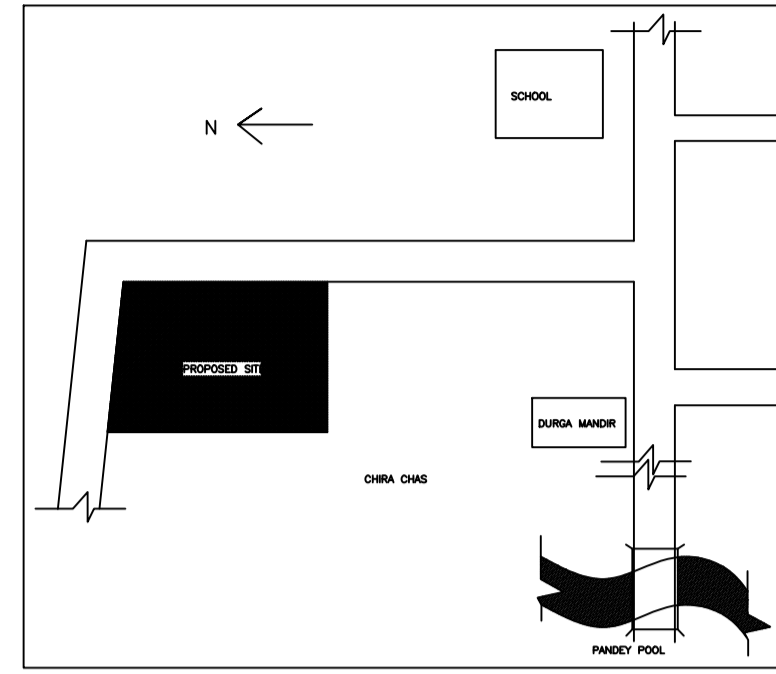
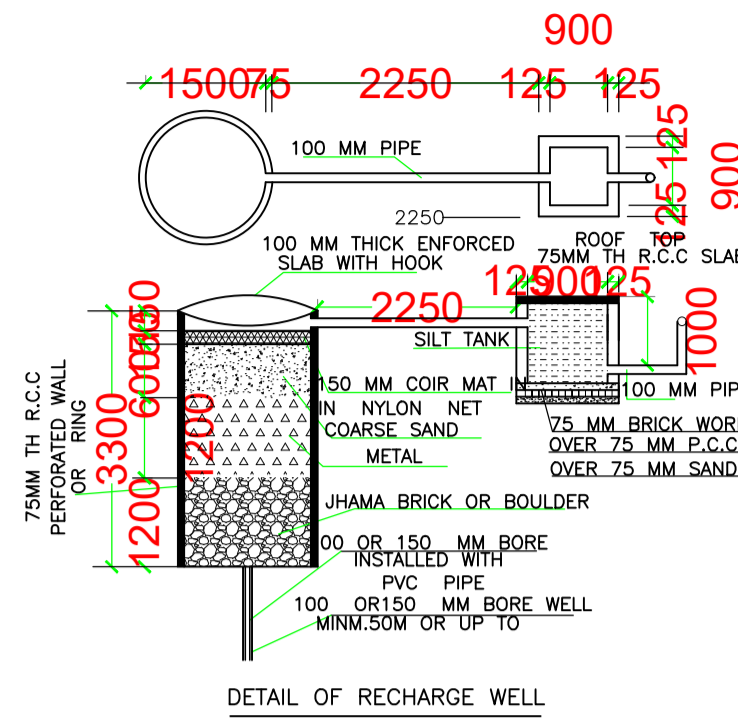
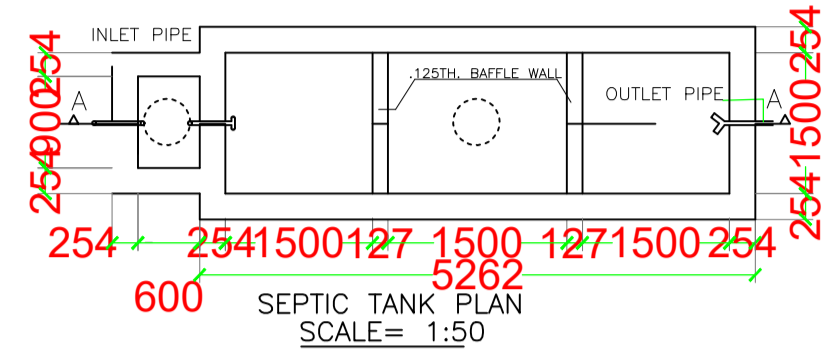
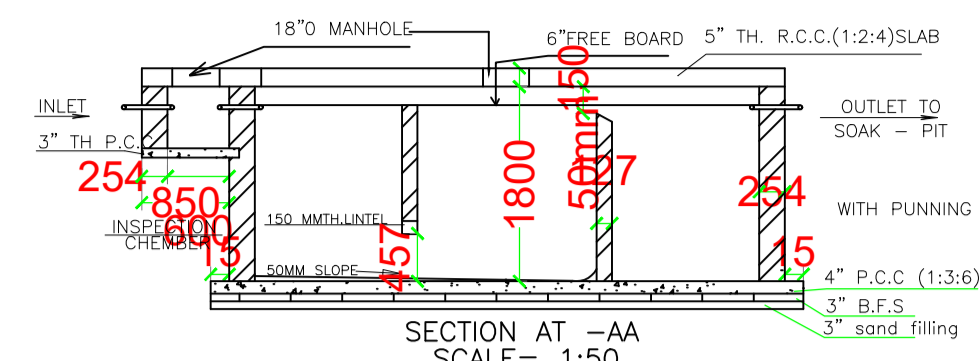

SCHEDULE OF DOOR:

BUILDING NAME	NAME	LENGTH	HEIGHT	NOS
A (BUILDING)	D	2.10	2.10	40
A (BUILDING)	V	0.90	2.10	48
A (BUILDING)	W	1.20	2.10	81
A (BUILDING)	W	0.96	1.20	56
A (BUILDING)	W	1.08	1.20	54
A (BUILDING)	W	1.35	1.20	41
A (BUILDING)	W	1.56	1.20	35
A (BUILDING)	W	1.76	1.20	30

SCHEDULE OF WINDOW/VENTILATION:

BUILDING NAME	NAME	LENGTH	HEIGHT	NOS
A (BUILDING)	V	3.43	1.20	56
A (BUILDING)	V	0.87	1.20	56
A (BUILDING)	W	0.96	1.20	56
A (BUILDING)	W	1.08	1.20	54
A (BUILDING)	W	1.35	1.20	41
A (BUILDING)	W	1.56	1.20	35
A (BUILDING)	W	1.76	1.20	30

Building -A (BUILDING)

Floor Name	Gross Built-up Area (Sq.mt)	Deductions From Gross Built-up Area (Sq.mt)	Net Built-up Area (Sq.mt)	Proposed FAR Area (Sq.mt)	Add FAR (Sq.mt)	Total FAR Area (Sq.mt)	Total Consumed FAR Area (Sq.mt)	Test (No)
Basement Floor	221.56	0.00	221.56	4.27	0.00	225.83	13.01	13.01
Ground Floor	212.89	3.35	209.54	0.00	0.00	209.54	209.54	01
First Floor	212.89	3.35	209.54	4.27	4.76	214.30	209.54	01
Second Floor	212.89	3.35	209.54	4.27	4.76	214.30	209.54	01
Third Floor	212.89	3.35	209.54	4.27	4.76	214.30	209.54	01
Fourth Floor	212.89	3.35	209.54	4.27	4.76	214.30	209.54	01
Temple Floor	0.00	0.00	0.00	0.00	0.00	0.00	0.00	00
Total	1282.00	16.75	1265.25	21.36	19.04	1284.29	1022.08	06

Required Parking (Table 7a)

Building Name	SubUse	Area (Sq.mt)	Reqd. No. of Pkgs	Prop. No. of Pkgs	Deficit	Excess	Vehicle Car	Two Wheeler
A (BUILDING)	Residential	1284.29	20	1	19	0	1	1
Total			20	1	19	0	1	1

Parking Check (Table 7b)

Vehicle Type	No. Reqd.	Area (Sq.mt)	No. Prop.	Area (Sq.mt)
Car	1	12.00	1	12.00
Two Wheeler	1	3.00	1	3.00
Total	2	15.00	2	15.00

Buildingwise Floor FAR Details

Floor Name	Proposed Built-up Area (Sq.mt)	Proposed FAR Area (Sq.mt)	Total FAR Area (Sq.mt)
Basement Floor	221.56	4.27	225.83
Ground Floor	209.54	0.00	209.54
First Floor	209.54	4.27	213.81
Second Floor	209.54	4.27	213.81
Third Floor	209.54	4.27	213.81
Fourth Floor	209.54	4.27	213.81
Temple Floor	0.00	0.00	0.00
Total	1284.29	19.04	1303.33

FAR & Tenement Details (Table 4c-1)

Building	No. of Same Bldg	Gross Built-up Area (Sq.mt)	Total FAR Area (Sq.mt)	Proposed FAR Area (Sq.mt)	Add FAR Area (Sq.mt)	Total FAR Area (Sq.mt)	Total Consumed FAR Area (Sq.mt)	Test (No)
A (BUILDING)	1	1284.29	19.04	19.04	0.00	19.04	19.04	06
Grand Total	1	1284.29	19.04	19.04	0.00	19.04	19.04	06

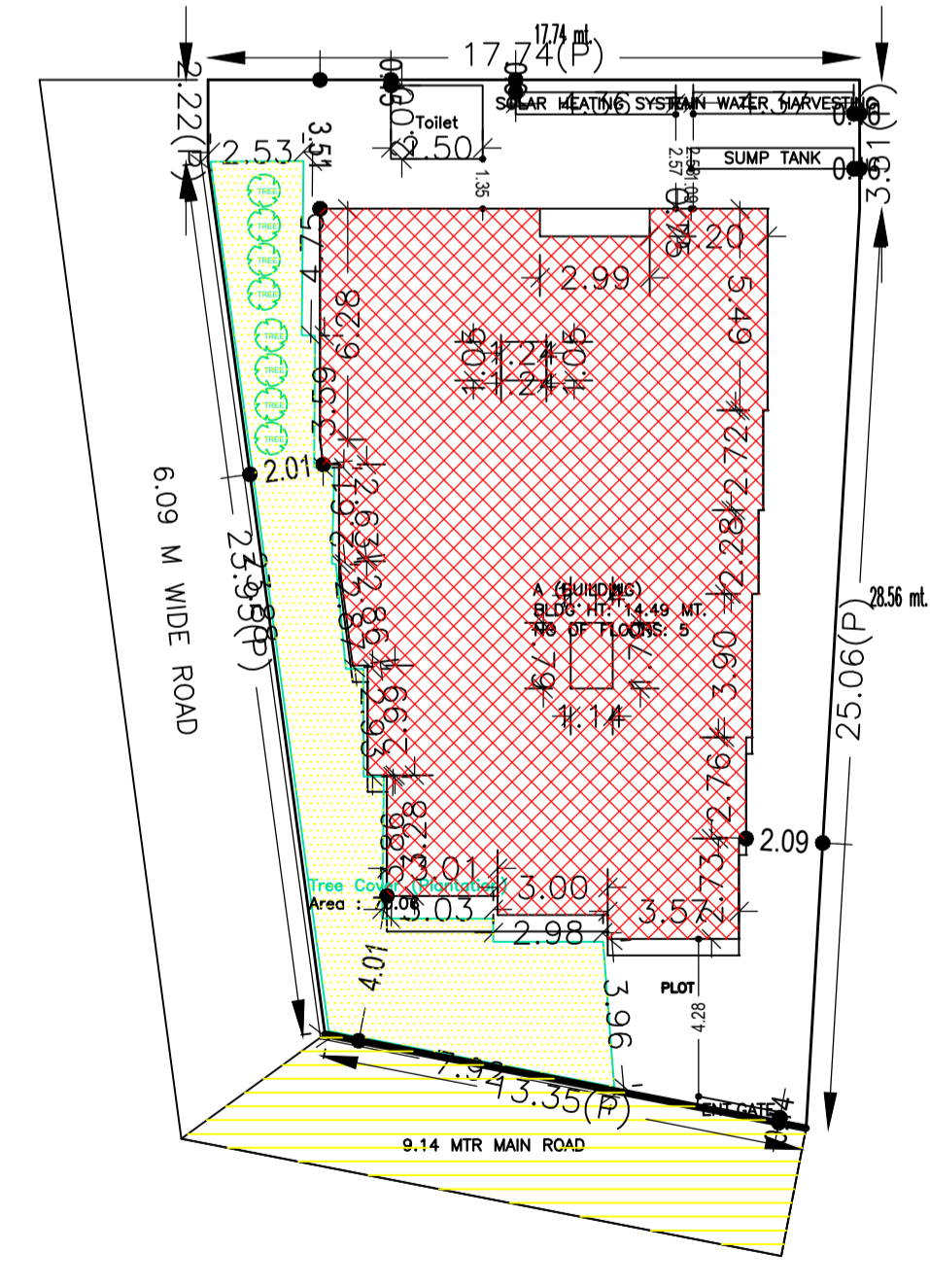
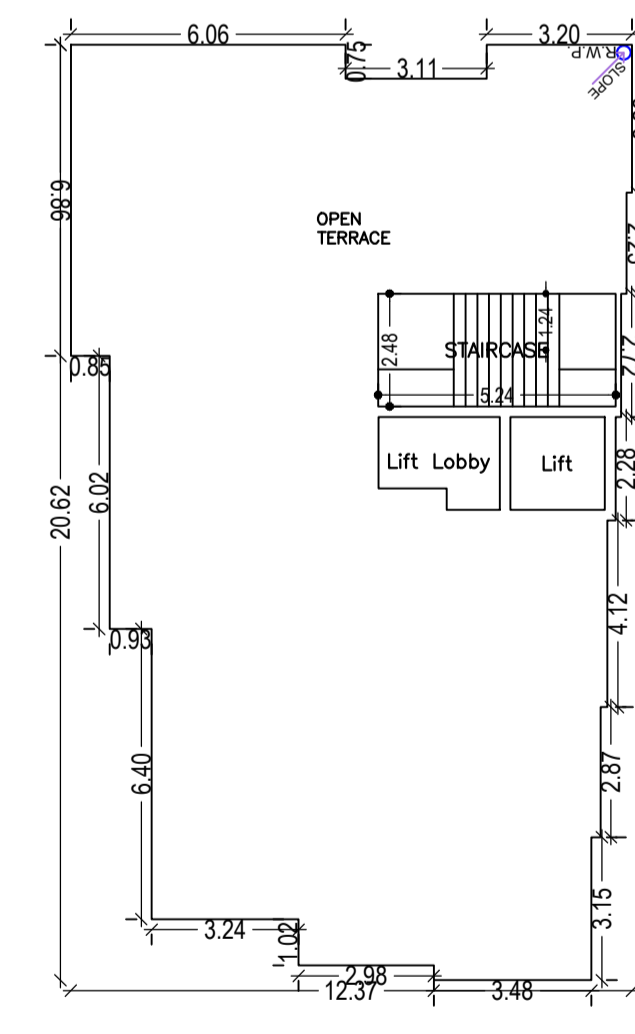
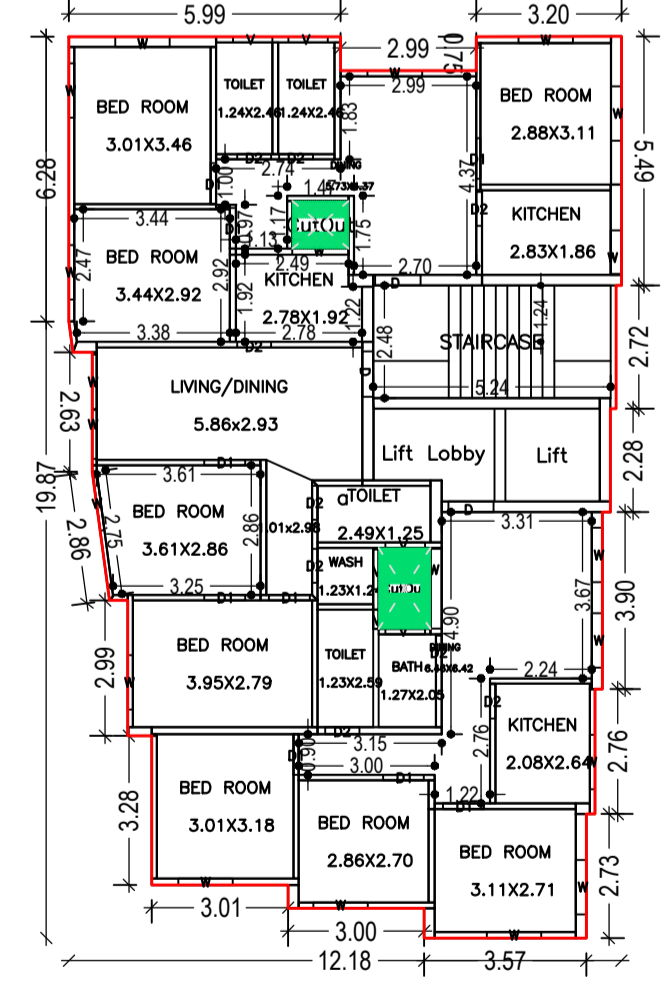
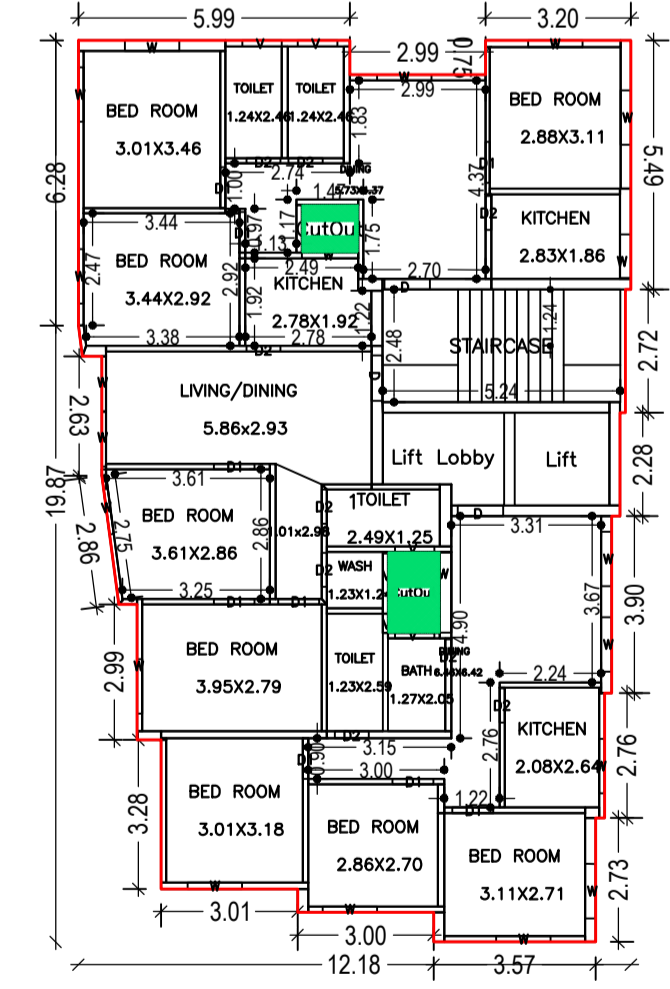
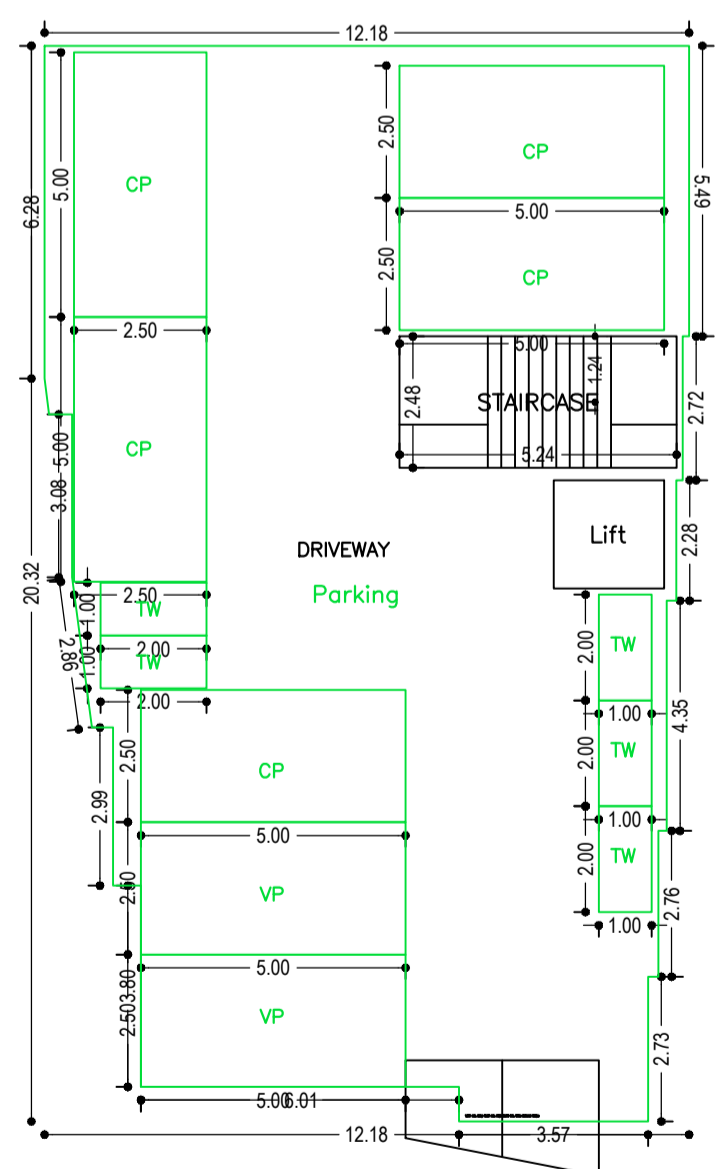

COLOR INDEX

PLOT BOUNDARY	[Black line]
ABUTTING ROAD	[Red line]
PROPOSED CONSTRUCTION	[Green line]
COMMON PLOT	[Blue line]
ROAD WIDENING AREA	[Yellow line]
EXISTING (To be retained)	[Light blue line]
EXISTING (To be demolished)	[Orange line]

LTP NAME AND SIGNATURE	Nirmal Kumar Sharma CMC/ARC/001/2017
STRUCTURAL ENG'S NAME AND SIGNATURE	
BUILDER NAME AND SIGNATURE	
DIGITAL SIGNATURE	