

Section at B ' B

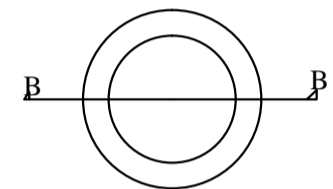

Sock pit plan

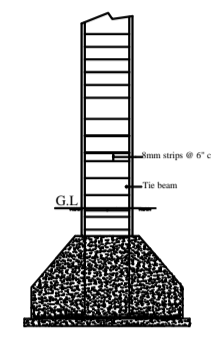

Section at C ' C

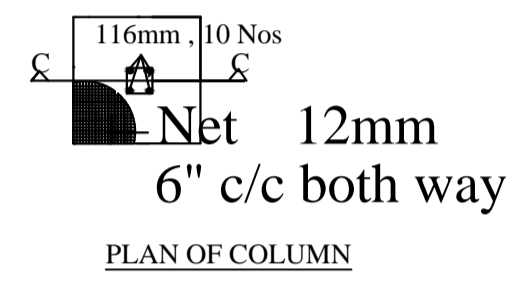

PLAN OF COLUMN

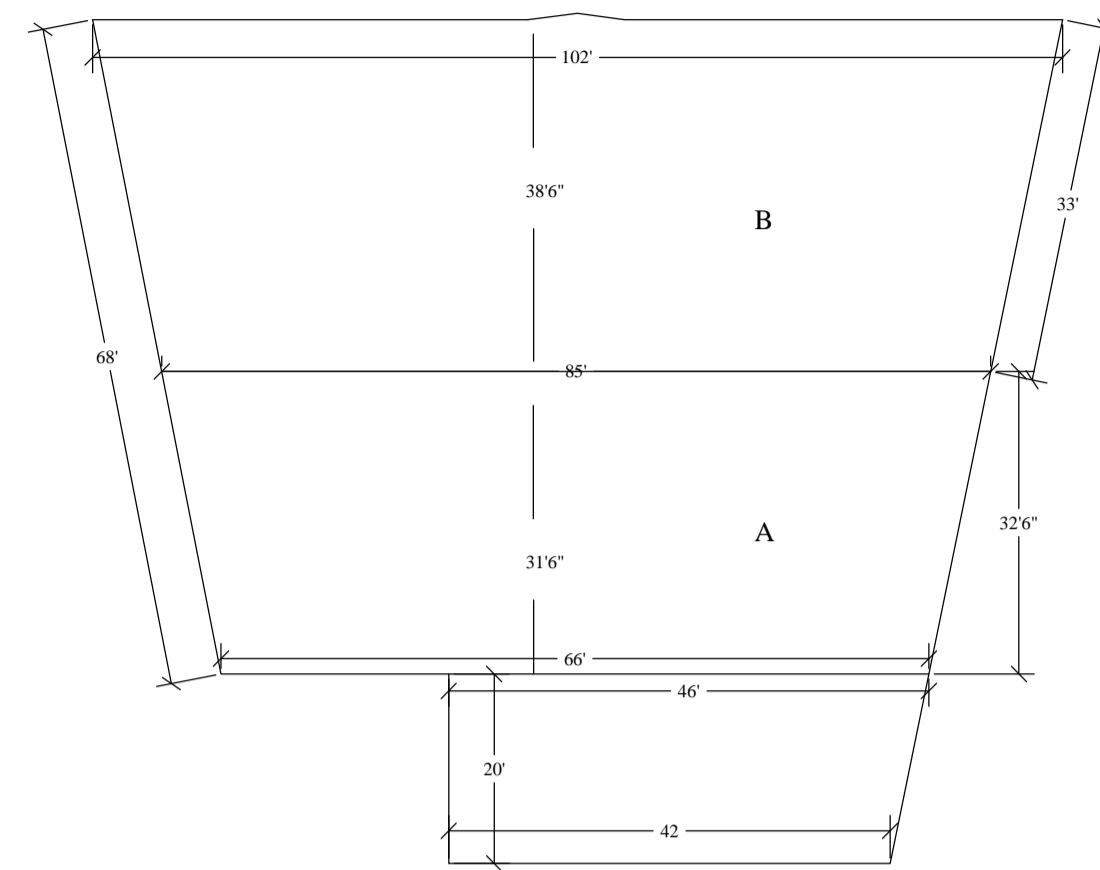
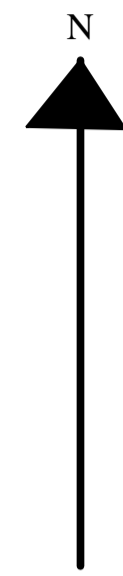

SITE PLAN

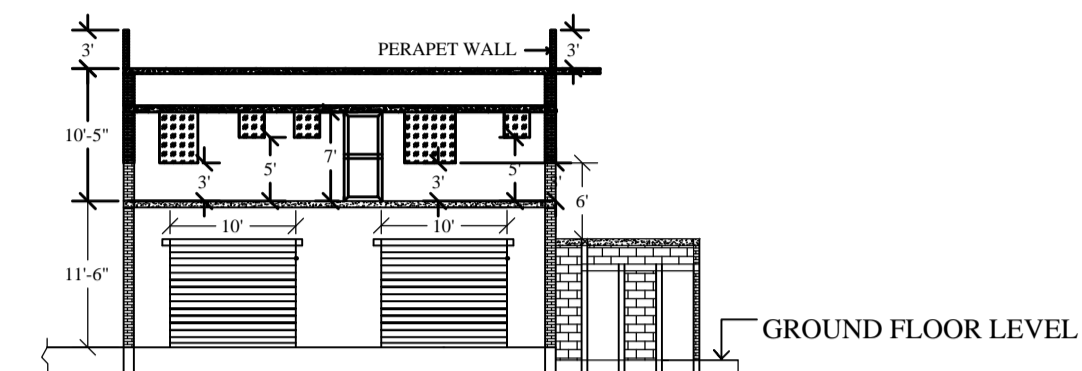

FRONT ELEVATION

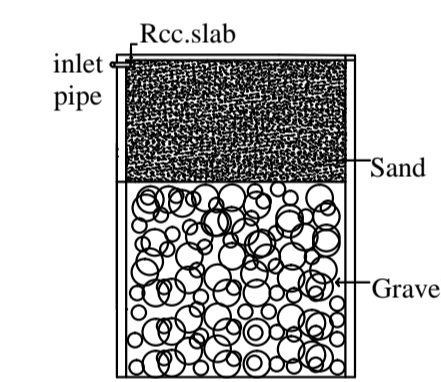

Section at D ' D

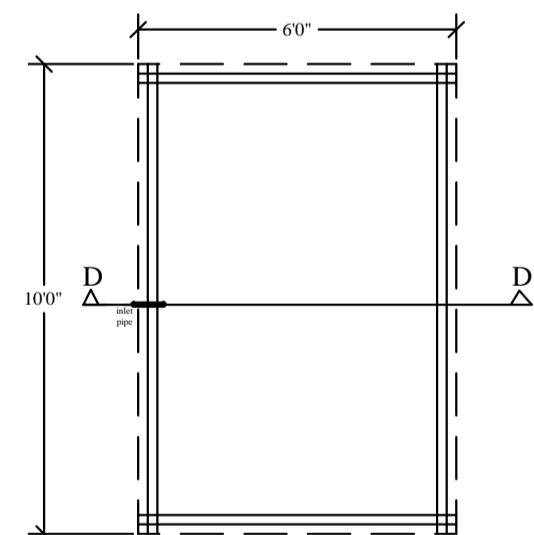

RAIN WATER HARVESTING

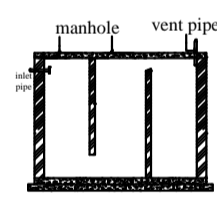

Section at A ' A

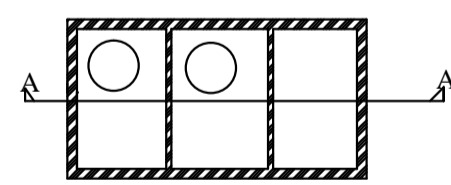

SEPTIC TANK PLAN

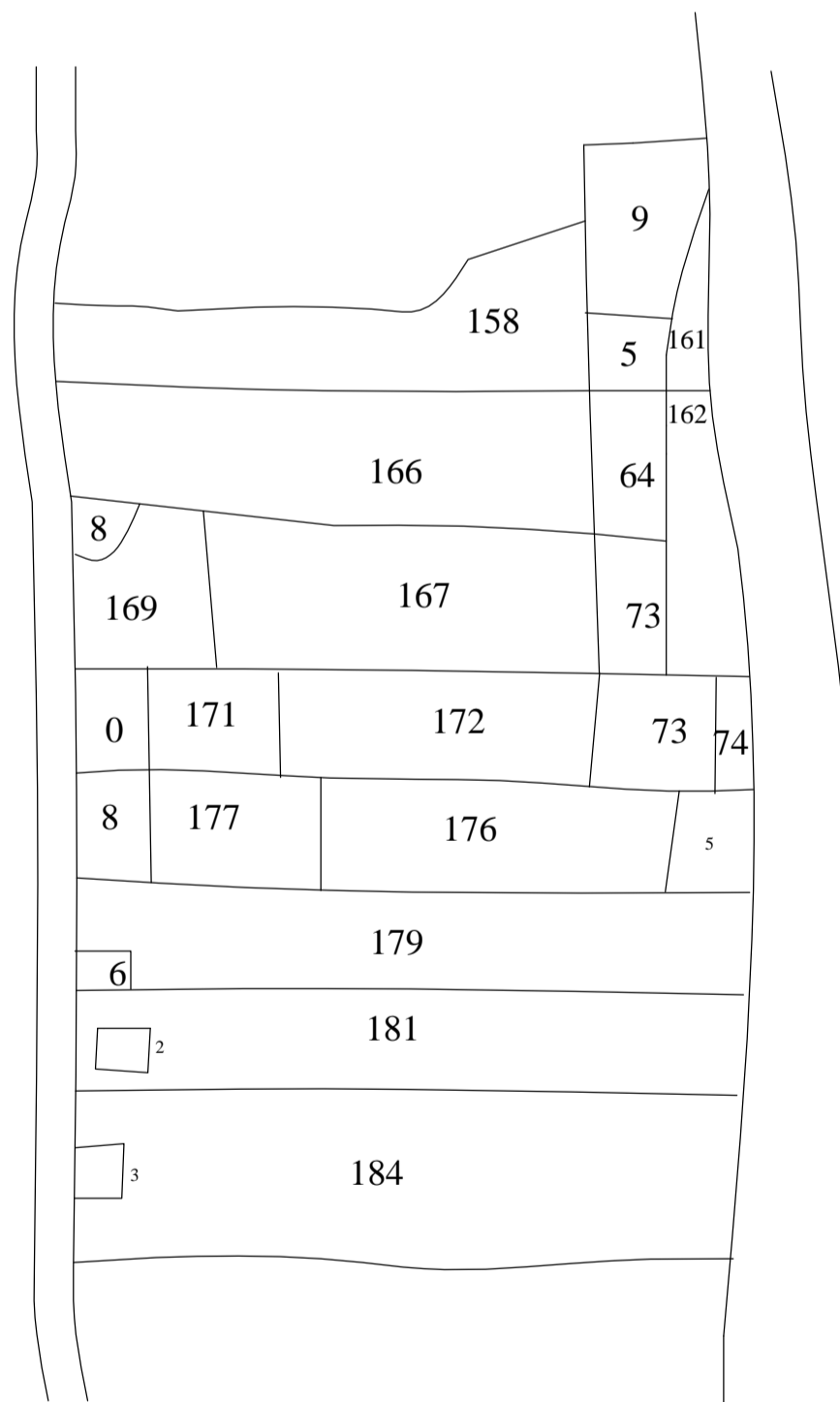

KEY PLAN

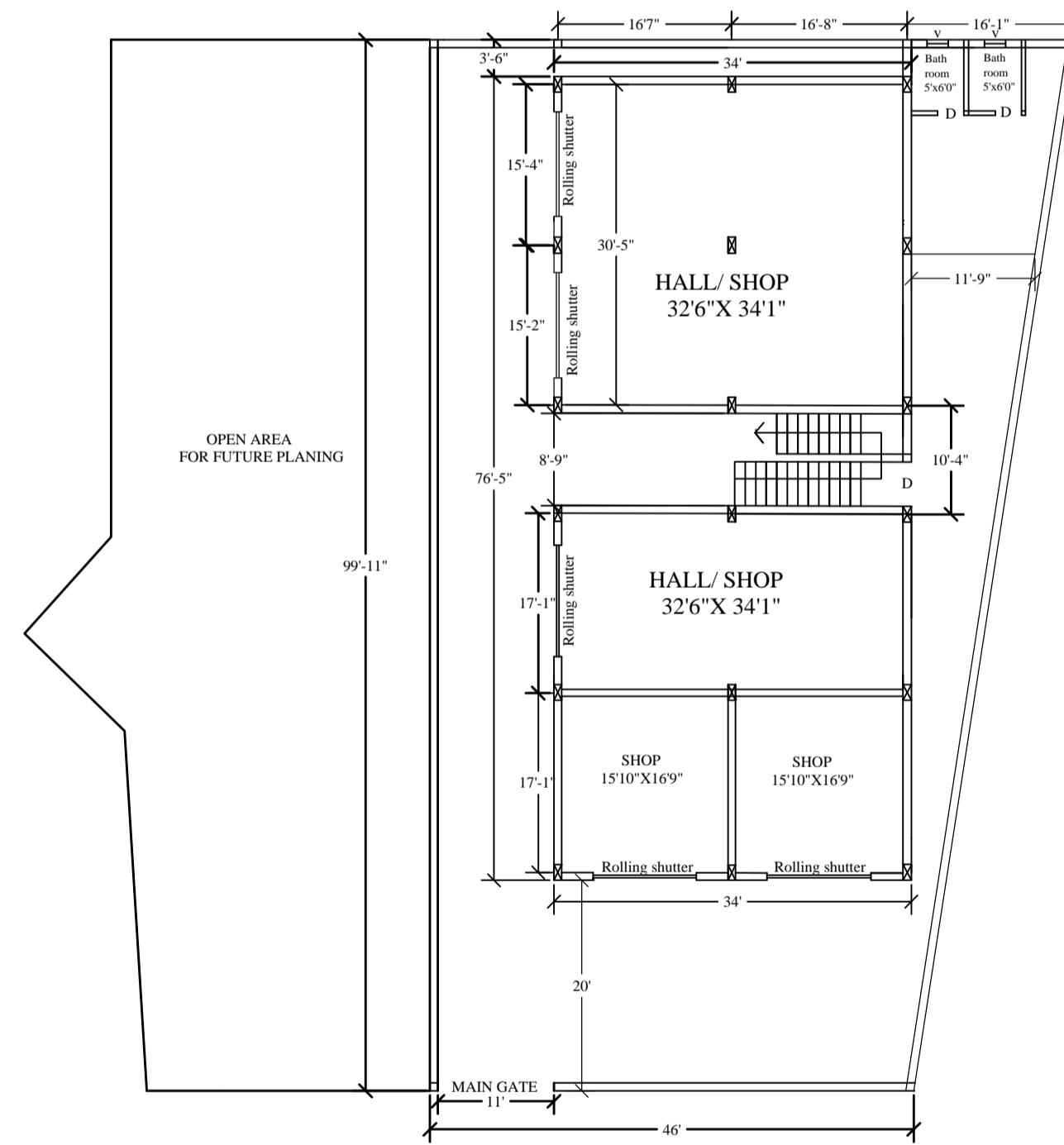

GROUND FLOOR PLAN

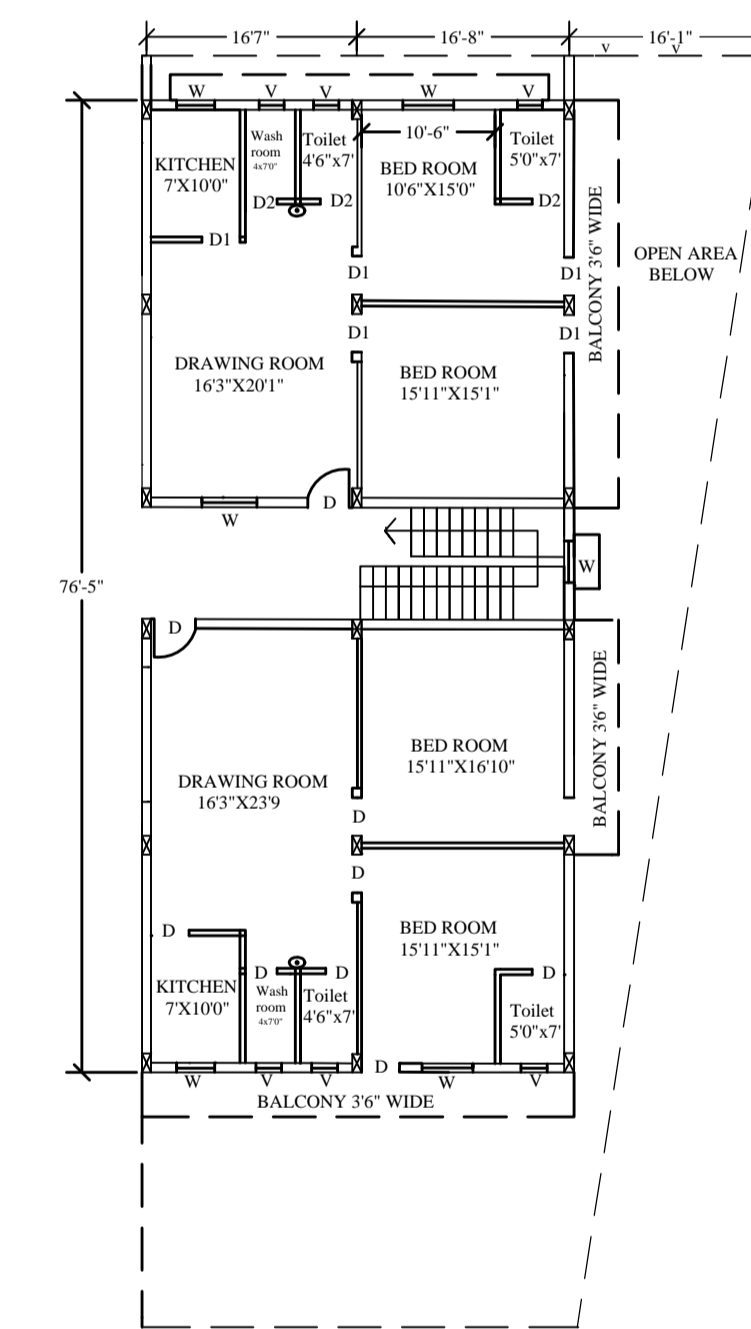

FIRST FLOOR PLAN

WASTE LAND IN FRONT OF PLOT

NATIONAL HIGHWAY NO 32

NATIONAL HIGHWAY NO 32

TITLE OF DRAWING

PROPOSED COMMERCIAL BUILDING OF AYODHYA RAMAN S/O GAYA RAMAN AT JAMGORIA CHAS DIST - BOKARO (JHARKHAND)

UNDER SURVEY

STATEMENT OF AREA

GROUND FLORR AREA	2598.28 , square feet
FIRST FLOOR AREA	2598.28 Square feet
TOTAL COVERED AREA	5196.56 Square feet
% OF PLYTH AREA	86.54%
FAR =	0.56

BRIEF SPECIFICATION

- All brick work 9" thick with first class brick in cement mortar (1:6)
- Half brick work 4.5" thick in cement mortar 1:4
- All r.c.c in proportion 1:1.5:3
- R.C.C footing, column 'beams, Lintels & roof slab to be constructed as per design.
- Roof slab should be 4" thick.
- Plaster on wall 12mm & ceiling 6mm CM..1:6:1:4.
- Concealed Electrical wiring with switch 'fuse unit & D.B.
- Anti-termite treatment in foundation to be done.
- Steel fe- 500 grade tmt steel shall be used
- Finishing first class approved quality

SCHEDULE OF DOOR WINDOW

TYPE	WIDTH	HEIGHT	SILL.	DESCRIPTION.
ROLLING SHUTTER	10'0"	9'0"	0.00	M.S FRAME AND SHUTTER
D	3'6"	7'0"	0.00	WOODEN DOOR FRAME / FLUSH DOOR
D1	3'6"	7'0"	0.00	
D2	3'6"	7'0"	0.00	
W	4'0"	4'0"	3'0"	
W1	4'0"	4'0"	3'0"	
V	2'0"	2'0"	5'0"	

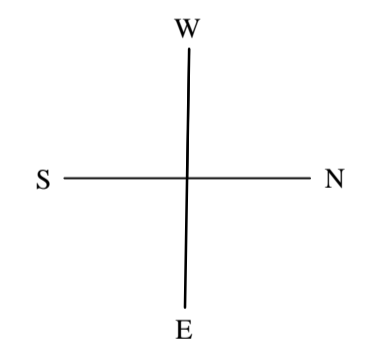

NOTE:-1. WRITTEN DIMENTION ARE TO BE FOLLOWED, NOT TO BE SCALED
2. (BUILDING CONSTRUCTION OF SANCTIONED PLAN IS VALLID UNDER SUPERVISION OF COMPETENT ENGINEER

APPLICANT'S SIGNATURE ENGINEER SIGNATURE

TITLE :- GROUND FLOOR PLAN , ELEVATION ,KEY PLAN SITE PLAN