

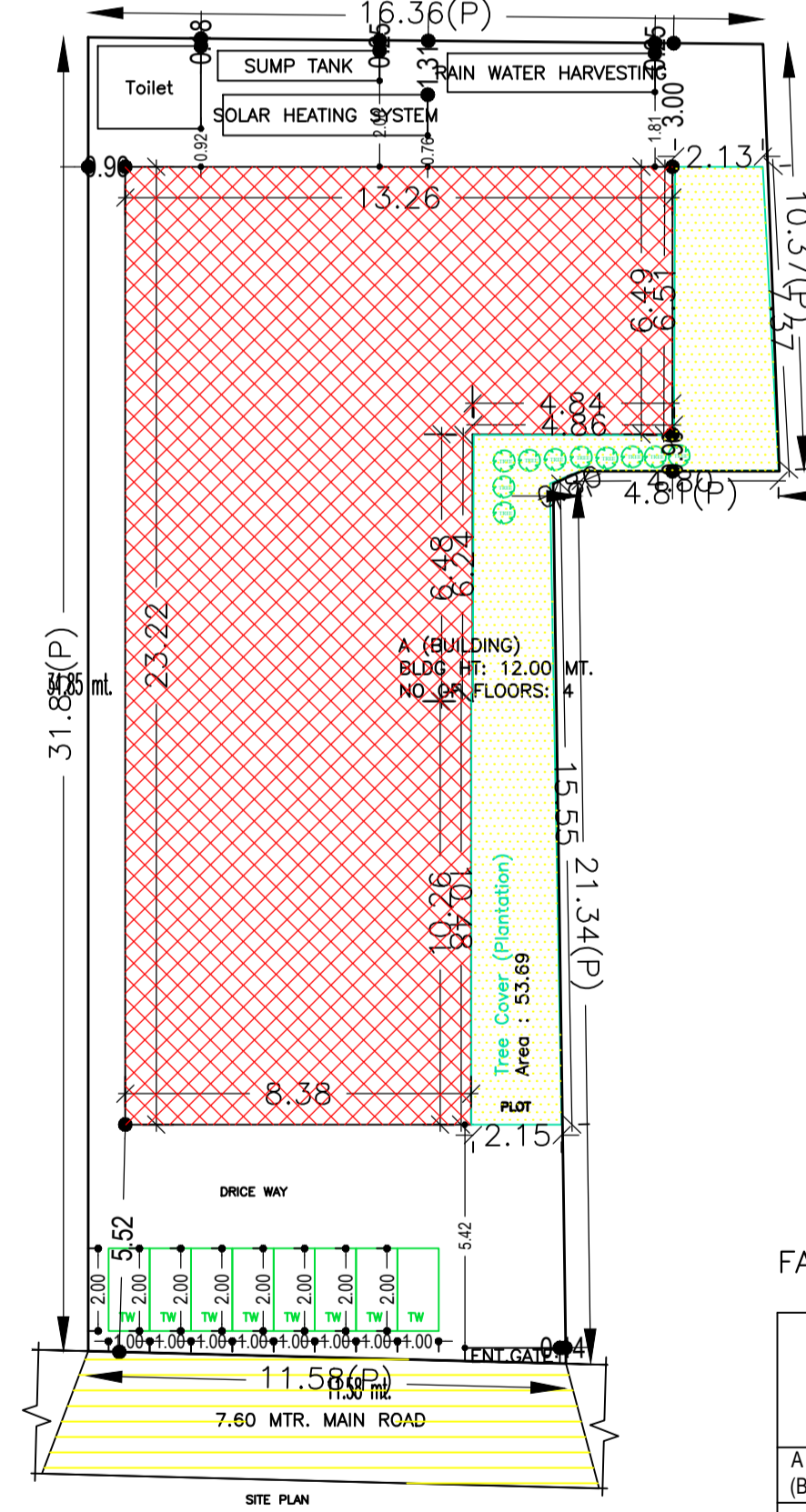

Proposal Basic Information

Proposal File No.	CMC/BP/0071/W02/2020/ALT1
Owner Name	NIRMALA DEVI
Khata No	382
Plot No	653
Village Name	Chas
Use	Mixed
SubUse	Resi+Comm

AREA STATEMENT CHAS MUNICIPAL CORPORATION		VERSION NO : 1.0.46
PROJECT DETAIL:		VERSION DATE: 22/06/2020
Region: JHARKHAND URBAN LOCAL BODIES	Plot Use: Mixed	
District: BOKARO	Plot SubUse: Resi+Comm	
Authority: CHAS MUNICIPAL CORPORATION	PlotNearbyReligiousStructure: NA	
Inward No: CMC/BP/0071/W02/2020/ALT1	PlotSubPlot No: 653	
Application Type: General Proposal	North: CTS No. - SATYA DEVI	
Project Type: Building Permission	South: CTS No. - KISTO MANDAL & RASTA	
Nature of Development: Addition or Alteration	East: CTS No. - BHUTU MANDAL	
Location of Development Area: Old Area	West: Road Width - 9.10	
AREA DETAILS:		SQ.MT.
AREA OF PLOT (Minimum)	(A)	418.25
NET AREA OF PLOT(Gross Plot Area - Deduction from Gross Plot area)	(A-Deductions)	418.25
Deduction for Balance Plot Area(from Gross Plot Area)		
Common Plot		53.69
Total		53.69
BALANCE AREA OF PLOT(Net Plot Area - Recreational/Amenity space)	(A-Deductions)	364.56
PLOT AREA FOR COVERAGE(Net Plot Area)	(A-Deductions)	418.25
Plot Area for FAR (Net Plot Area + RoadWidening Area)	(A-Deductions)	418.25
COVERAGE CHECK		
Permissible Coverage area (60.00 %)		250.95
Proposed Coverage Area (54.15 %)		226.47
Total Prop. Coverage Area (54.15 %)		226.47
Balance coverage area (5.85 %)		24.48
FAR CHECK		
Perm. FAR Area (2.50)		1045.63
Total Perm. FAR area		1045.63
Residential FAR		475.80
Commercial FAR		452.52
Proposed FAR Area		928.32
Total Proposed FAR Area		928.32
Consumed FAR (Factor)		2.22
Balance FAR Area		117.31
BUILT UP AREA CHECK		
Total Proposed BuiltUp Area		961.23
ARCHITECT (Regd)	Ravish Chandra Khanna	
ENGINEER (Regd)		
SUPERVISOR (Regd)		
OWNER (Regd)	NIRMALA DEVI	
DEVELOPMENT AUTHORITY		LOCAL BODY

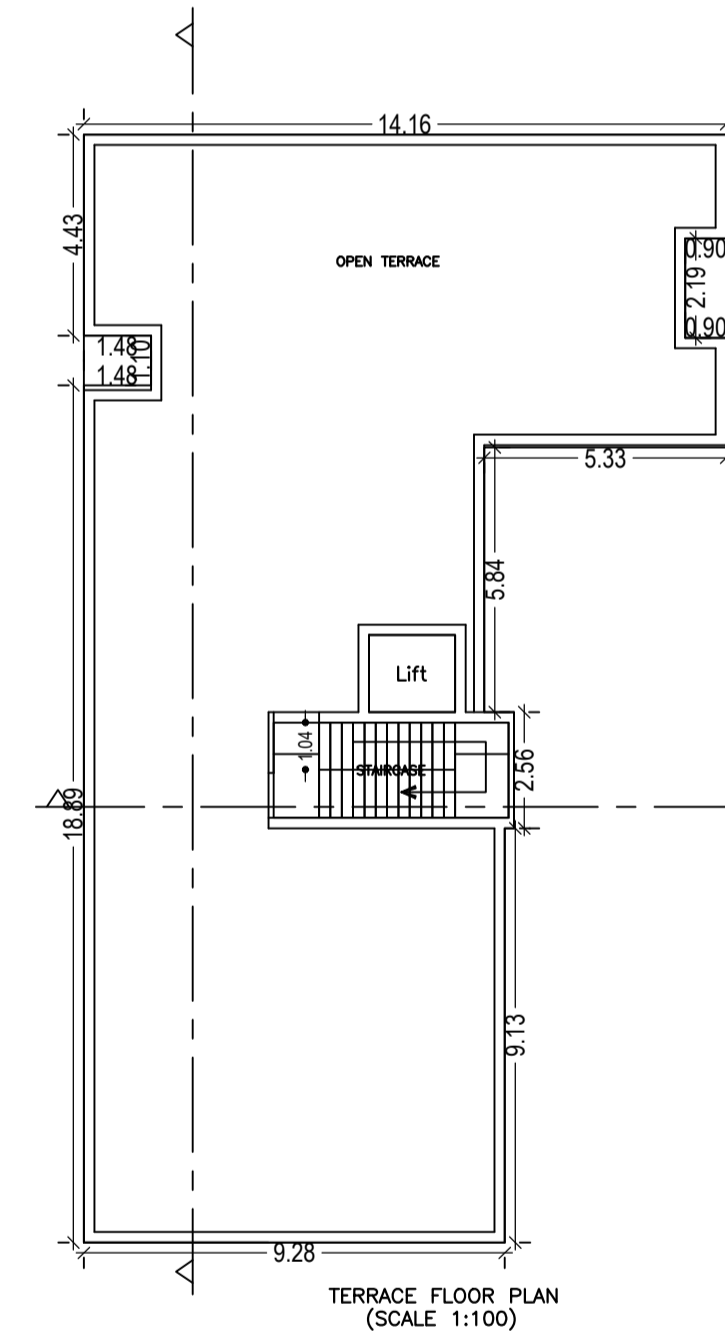
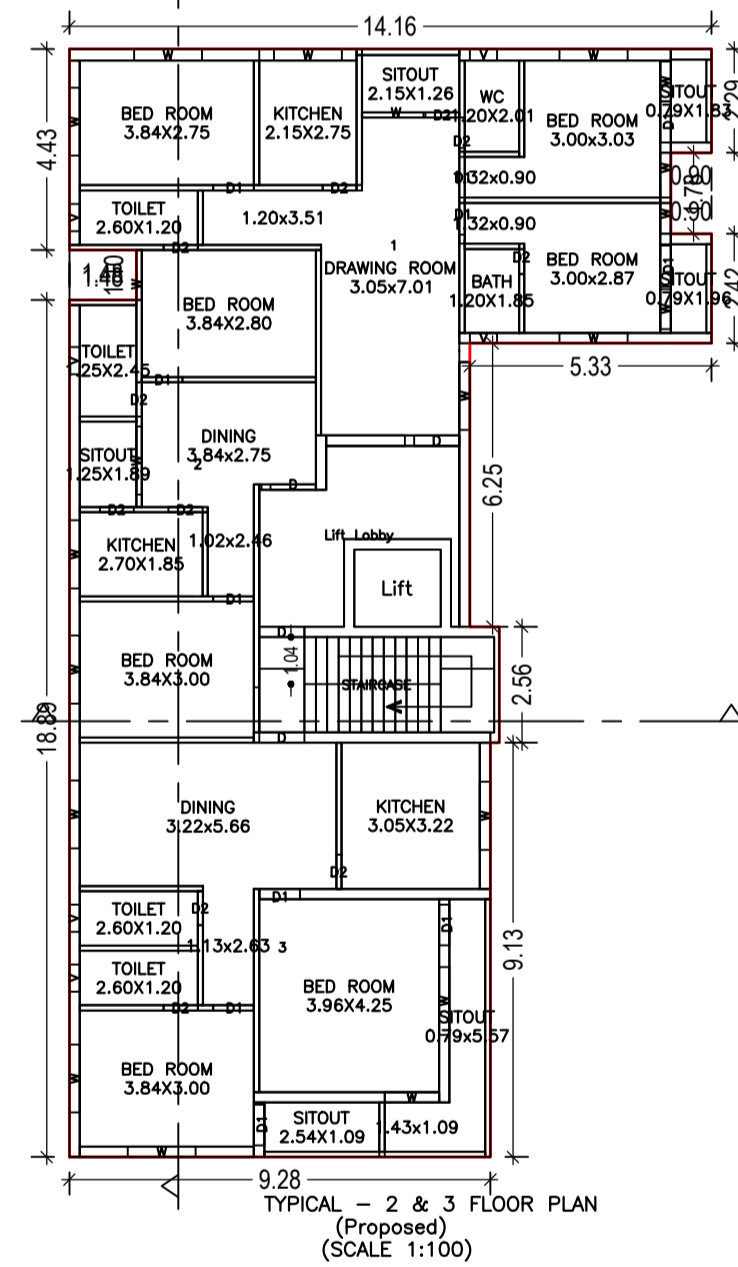
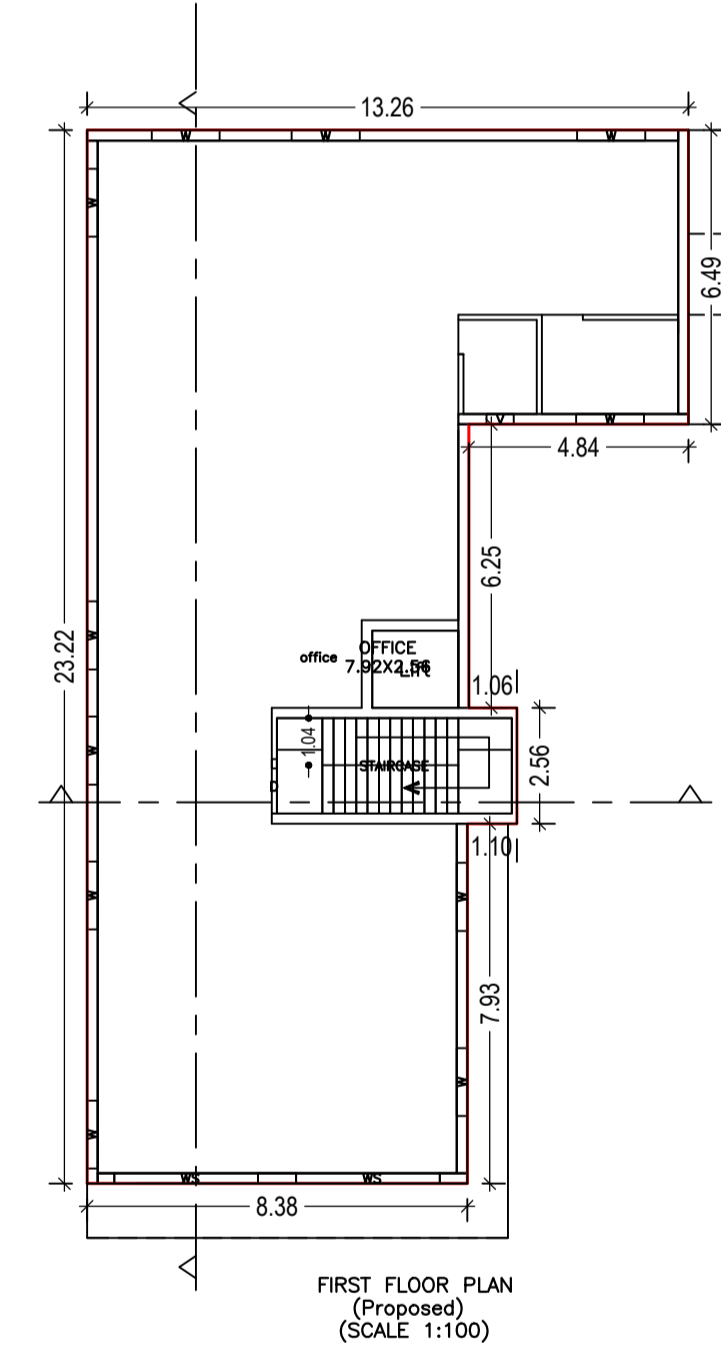
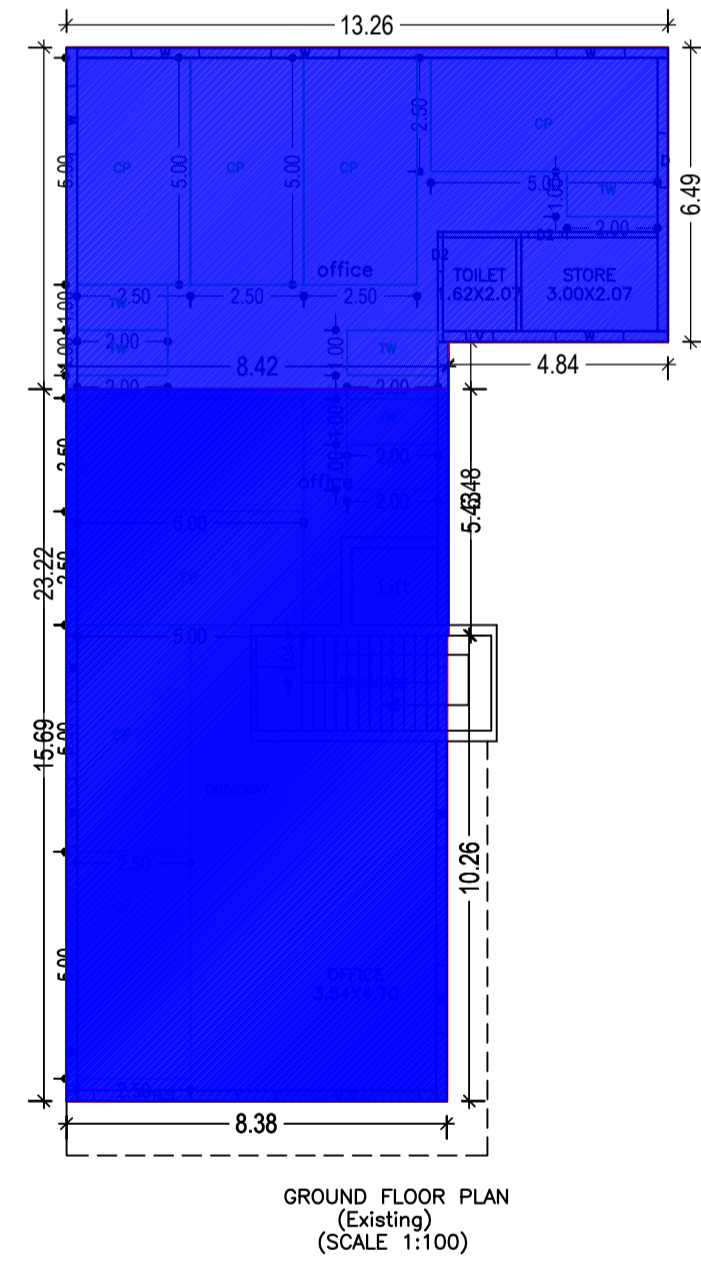
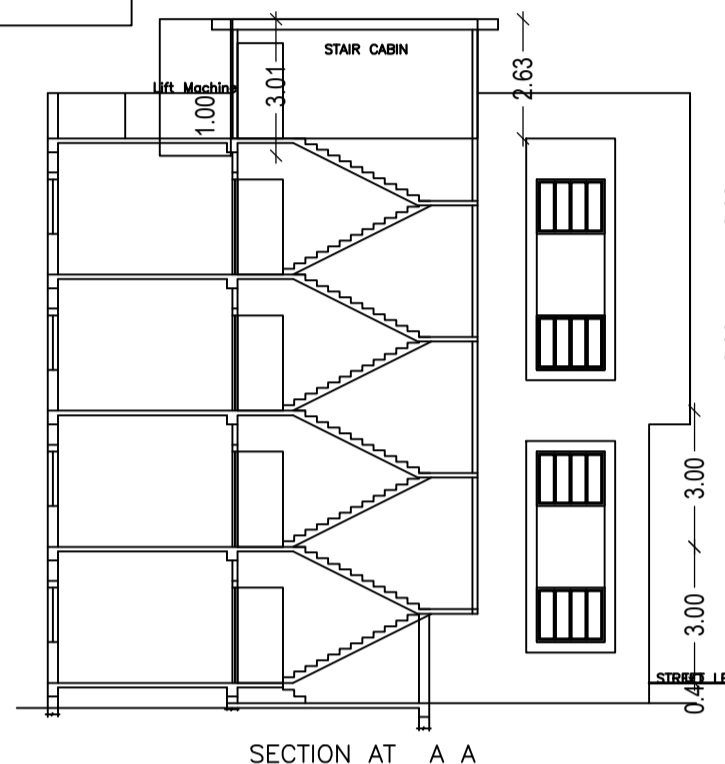
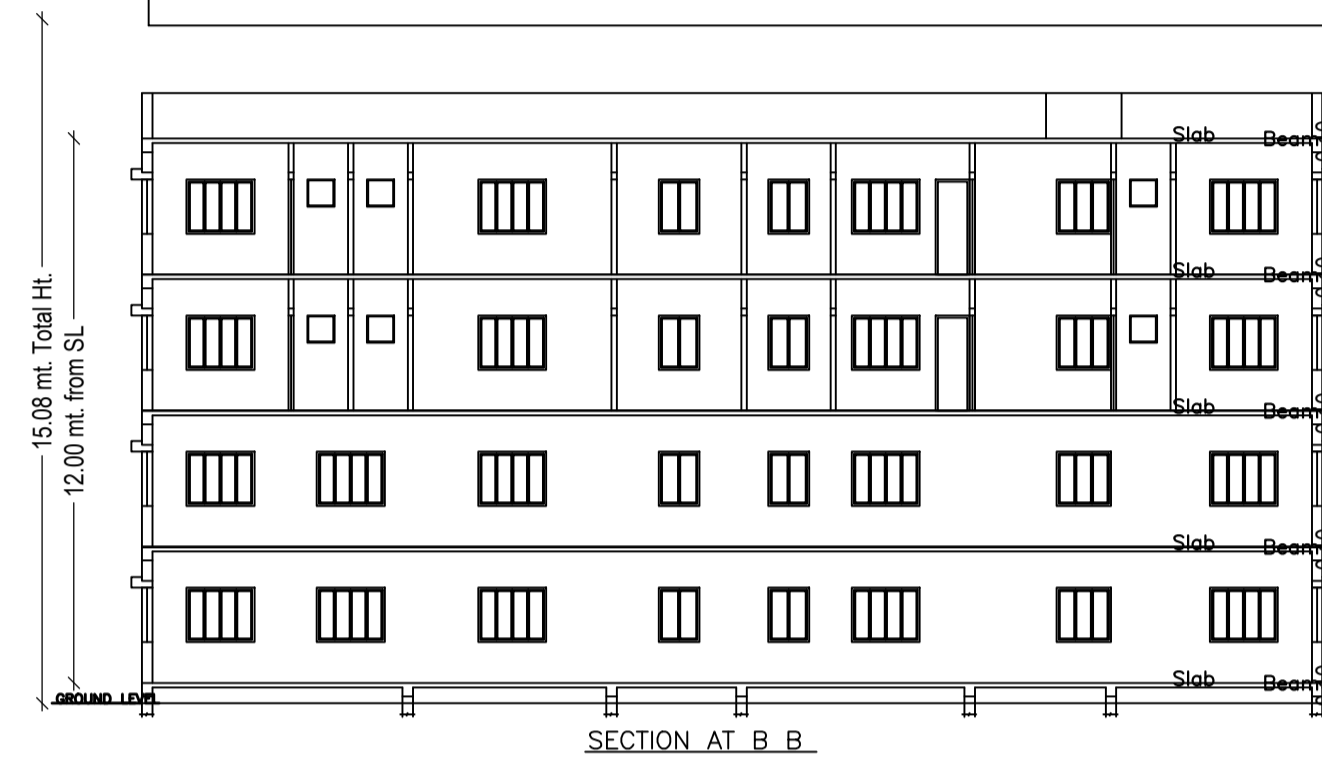
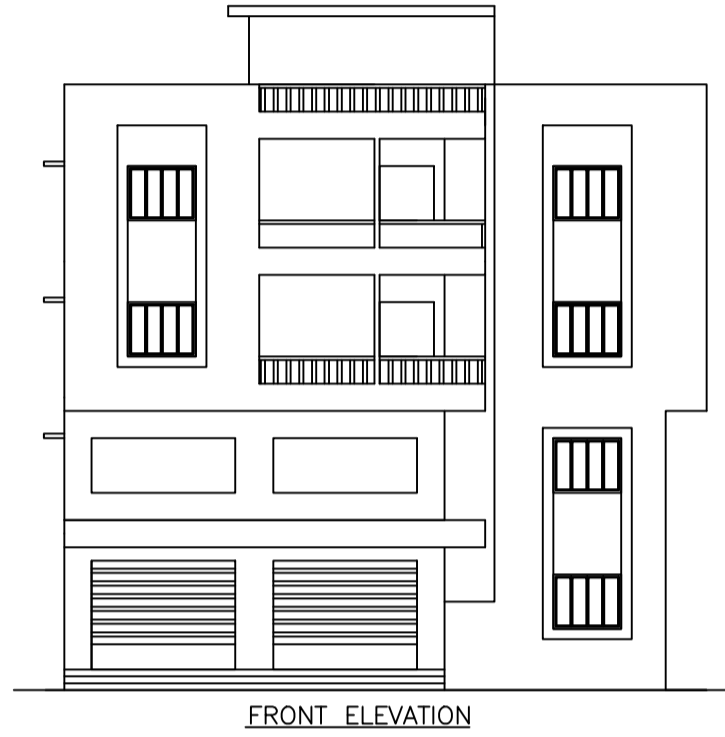
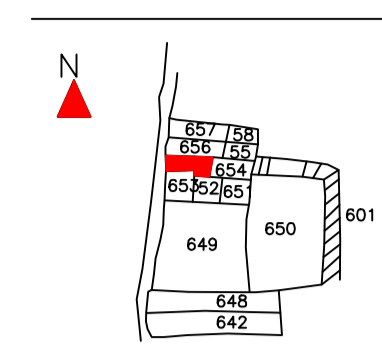
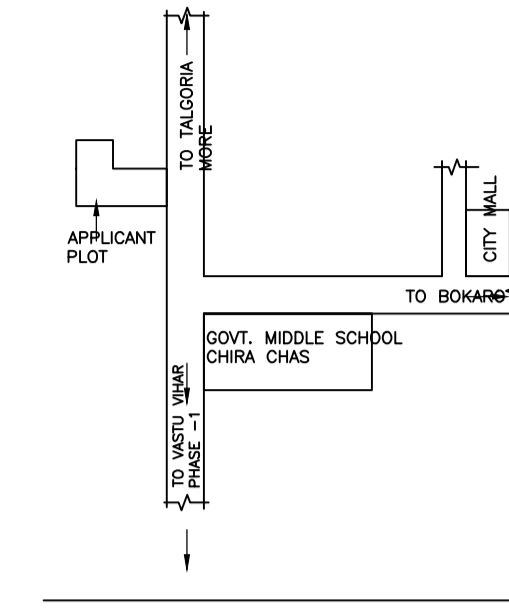
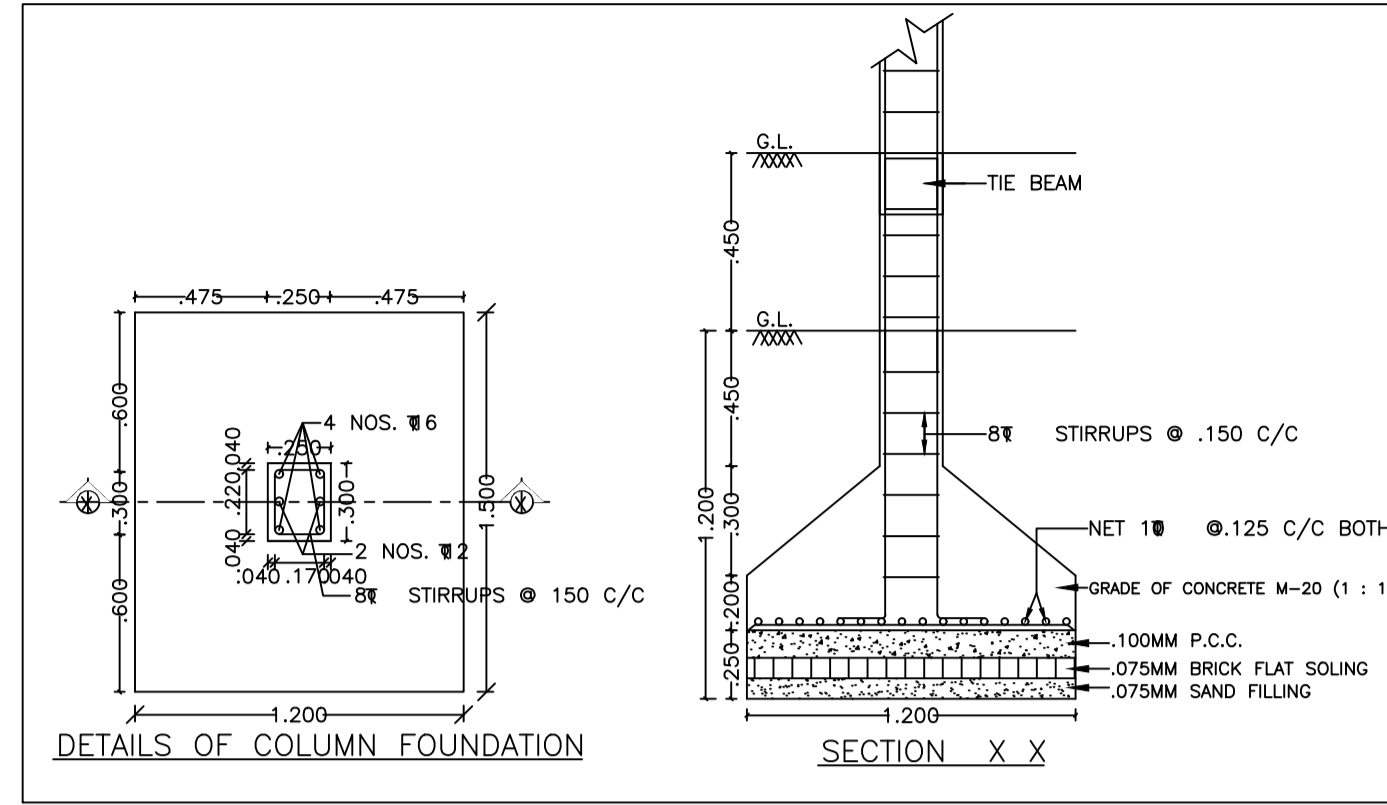
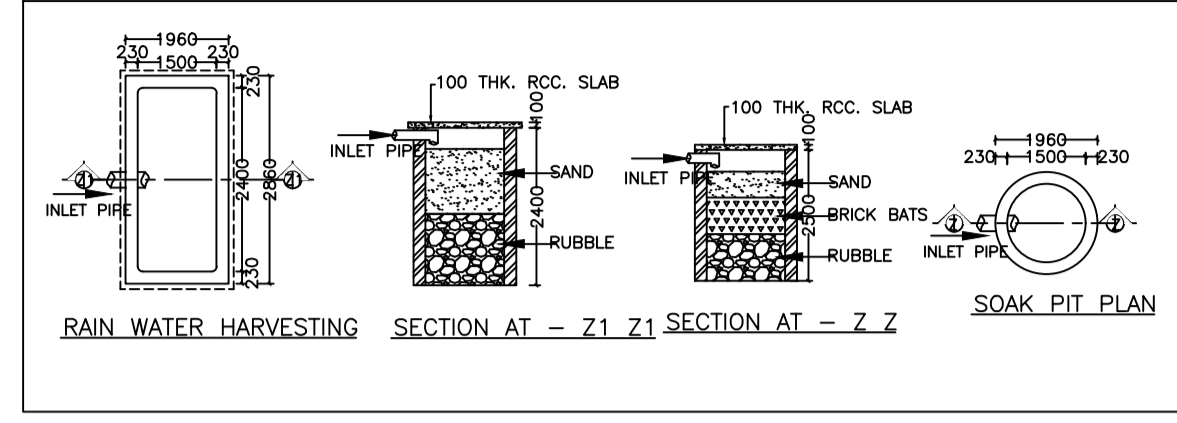
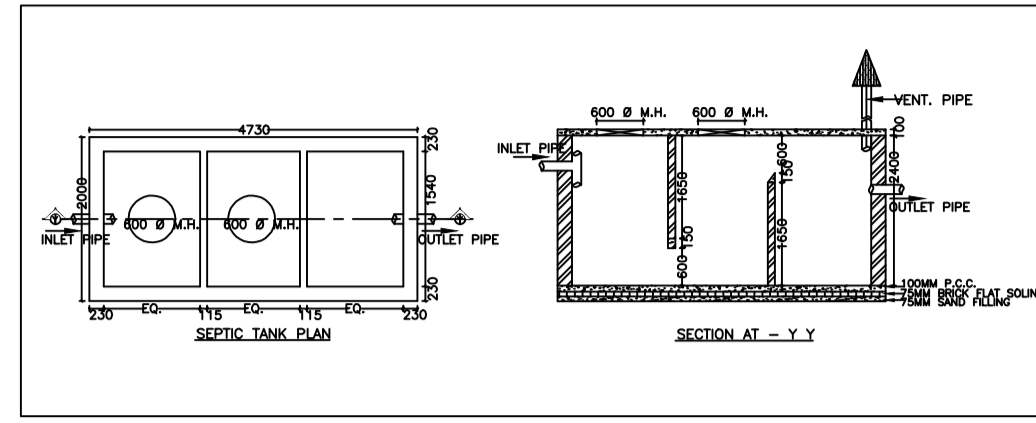

SCHEDULE OF DOOR:

BUILDING NAME	NAME	LENGTH	HEIGHT	NOS
A (BUILDING)	D2	0.55	2.10	02
A (BUILDING)	D2	0.75	2.10	22
A (BUILDING)	D1	0.90	2.10	22
A (BUILDING)	D	1.00	2.10	06
A (BUILDING)	D	1.20	2.10	01
A (BUILDING)	R.S.	3.16	2.45	01

SCHEDULE OF WINDOW/VENTILATION:

BUILDING NAME	NAME	LENGTH	HEIGHT	NOS
A (BUILDING)	V	0.60	0.90	14
A (BUILDING)	W	0.68	1.20	02
A (BUILDING)	W	0.88	1.20	04
A (BUILDING)	W	0.99	1.20	02
A (BUILDING)	W	1.10	1.20	02
A (BUILDING)	W	1.20	1.20	02
A (BUILDING)	W	1.36	1.20	02
A (BUILDING)	W	1.50	1.20	41
A (BUILDING)	WS	3.17	1.20	02

Buildingwise Floor FAR Details

Floor Name	Building Name A (BUILDING)				Total			
	Proposed Built Up Area (Sq.mt.)	Existing Built up Area (Sq.mt.)	Proposed FAR Area (Sq.mt.)	Existing FAR Area (Sq.mt.)	Total Proposed Built Up Area (Sq.mt.)	Total Existing Built up Area (Sq.mt.)	Total FAR Area (Sq.mt.)	Total Existing FAR Area (Sq.mt.)
Ground Floor	0.00	226.47	0.00	226.47	0.00	226.47	0.00	226.47
First Floor	229.28	0.00	226.05	0.00	229.28	0.00	226.05	0.00
Second Floor	252.74	0.00	237.90	0.00	252.74	0.00	237.90	0.00
Third Floor	252.74	0.00	237.90	0.00	252.74	0.00	237.90	0.00
Terrace Floor	0.00	0.00	0.00	0.00	0.00	0.00	0.00	0.00
Total	734.76	226.47	701.85	226.47	734.76	226.47	701.85	226.47

Required Parking (Table 7a)

Building Name	Type	SubUse	Car			Visitors Car			TwoWheeler				
			Area (Sq.mt.)	Reqd.	Prop.	Reqd./Unit	Reqd.	Prop.	Reqd./Unit	Reqd.	Prop.		
A (BUILDING)	Mixed	Mixed	> 0	100	215.17	1	2	-	-	-	-	-	
			> 0	100	215.17	1	2	-	-	-	-	-	
			> 0	100	215.17	1	2	-	-	-	-	-	
			> 0	100	215.17	1	2	-	-	-	-	-	
			> 0	100	215.17	1	2	-	-	-	-	-	
A (BUILDING)	Residential	Residential Bldg/Apartment	> 0	1	6.00	1.00	6	-	-	-	-	-	
			> 0	1	6.00	-	-	-	-	-	-	-	
			> 0	1	6.00	-	-	-	-	-	-	-	
Total :			-	-	-	10	10	-	1	2	-	16	16

Parking Check (Table 7b)

Vehicle Type	Reqd.		Prop.	
	No.	Area	No.	Area
Car	-	-	10	125.00
Total Car	10	125.00	10	125.00
Visitors Car Parking	-	-	2	25.00
Total Visitor Parking	1	12.50	2	25.00
TwoWheeler	-	-	16	32.00
Total TwoWheeler	16	32.00	16	32.00
Total	-	169.50	-	239.00

UnitBUA Table for Building :A (BUILDING)

FLOOR	Name	UnitBUA Type	Entity Type	UnitBUA Area	Carpet Area	No. of Rooms	No. of Tenement
GROUND FLOOR PLAN	office	OFFICE	Existing	94.80	88.21	2	-
	office	OFFICE	Existing	128.44	124.74	1	3
	office	OFFICE	Existing	128.44	124.74	1	-
FIRST FLOOR PLAN	office	OFFICE	Proposed	226.05	210.07	1	1
TYPICAL - 2 & 3 FLOOR PLAN	1	FLAT	Proposed	73.95	71.45	10	-
	2	FLAT	Proposed	49.92	48.36	7	6
	3	FLAT	Proposed	79.68	75.36	8	-
Total:	-	-	-	984.84	938.12	55	10

Building USE/SUBUSE Details

Building Name	Building Use	Building SubUse	Building Structure
A (BUILDING)	Residential	Residential Bldg/Apartment	Non-Highrise

Building :A (BUILDING)

Floor Name	Total Built Up Area (Sq.mt.)	Existing Built Up Area (Sq.mt.)	Proposed Built Up Area (Sq.mt.)	Deductions (Area in Sq.mt.)	Existing FAR Area (Sq.mt.)	Proposed FAR Area (Sq.mt.)	Total FAR Area (Sq.mt.)	Total Consumed Additional FAR Area (Sq.mt.)	Trmt (No.)
Ground Floor	226.47	226.47	0.00	0.00	0.00	226.47	0.00	226.47	03
First Floor	229.28	0.00	229.28	3.23	0.00	0.00	226.05	226.05	01
Second Floor	252.74	0.00	252.74	3.23	11.61	0.00	237.90	237.90	03
Third Floor	252.74	0.00	252.74	3.23	11.61	0.00	237.90	237.90	03
Terrace Floor	0.00	0.00	0.00	0.00	0.00	0.00	0.00	0.00	00
Total :	961.23	226.47	734.76	9.69	23.22	226.47	475.80	928.32	10
Total Number of Same Buildings :	1								
Total :	961.23	226.47	734.76	9.69	23.22	226.47	475.80	928.32	10

FAR & Tenement Details (Table 4c-1)

Building	No. of Same Bldg	Total Built Up Area (Sq.mt.)	Existing Built Up Area (Sq.mt.)	Proposed Built Up Area (Sq.mt.)	Deductions (Area in Sq.mt.)	Existing FAR Area (Sq.mt.)	Proposed FAR Area (Sq.mt.)	Total FAR Area (Sq.mt.)	Total Consumed Additional FAR Area (Sq.mt.)	Trmt (No.)
A (BUILDING)	1	961.23	226.47	734.76	9.69	23.22	226.47	475.80	928.32	10
Grand Total	1	961.23	226.47	734.76	9.69	23.22	226.47	475.80	928.32	10

COLOR INDEX

Color	Description
Black	PLOT BOUNDARY
Red	ABUTTING ROAD
Green	PROPOSED CONSTRUCTION
Yellow	COMMON PLOT
Blue	ROAD WIDENING AREA
White	EXISTING (To be retained)
Grey	EXISTING (To be demolished)

LTP NAME AND SIGNATURE	STRUCTURAL ENG'S NAME AND SIGNATURE	BUILDER NAME AND SIGNATURE	DIGITAL SIGNATURE
Ravish Chandra Khanna CMC/ARC/0010/2017			