

Project Title: SMT. MAMTA KUMARI W/O- UPENDRA PRASAD IN MOUZA - CHAS , P.S- CHAS, P.S NO.-30 KHATA NO.-176 , PLOT NO.-7395 AREA -3.7/8 DECIMAL IN DIST- BOKARO (JHARKHAND)

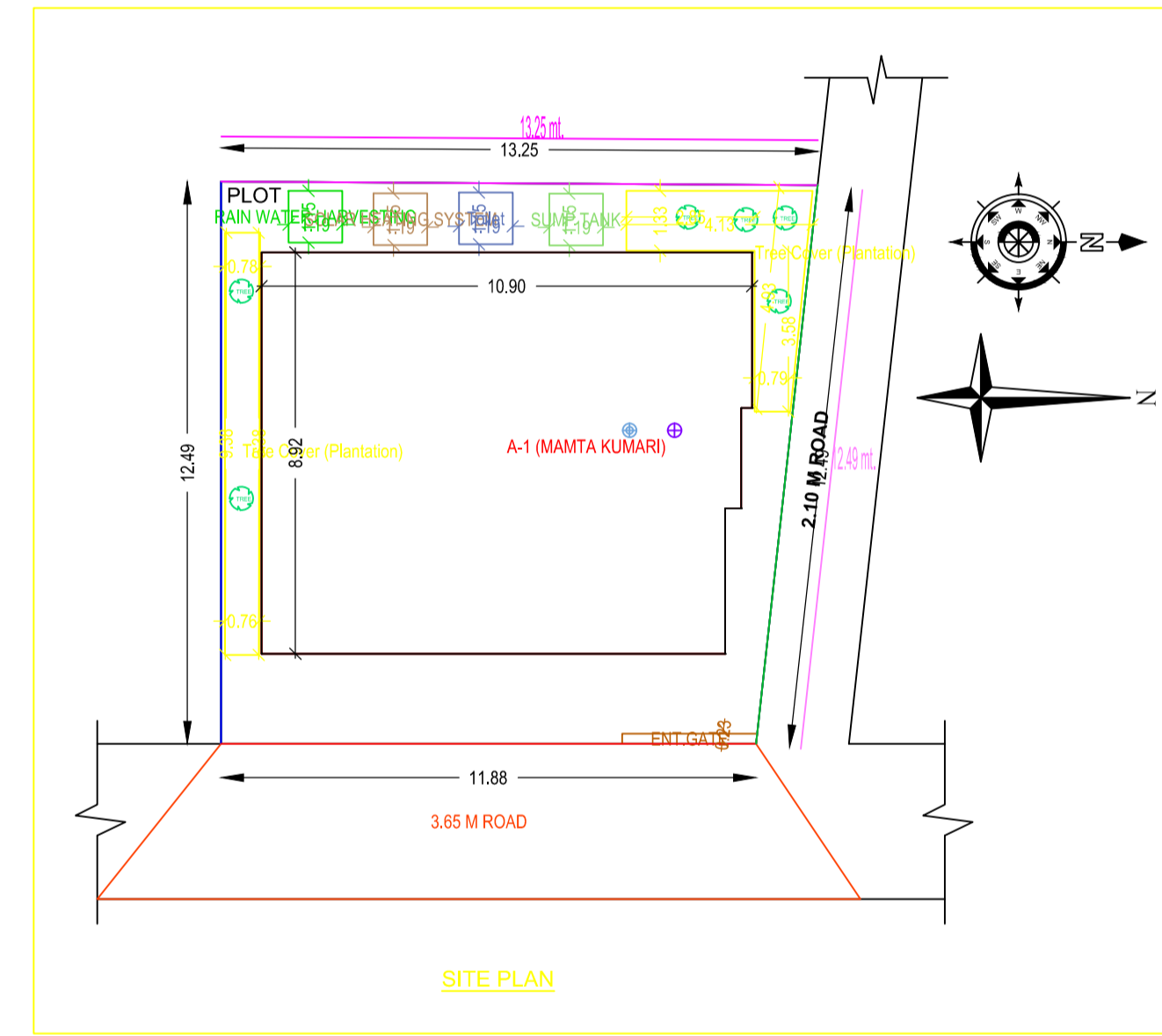
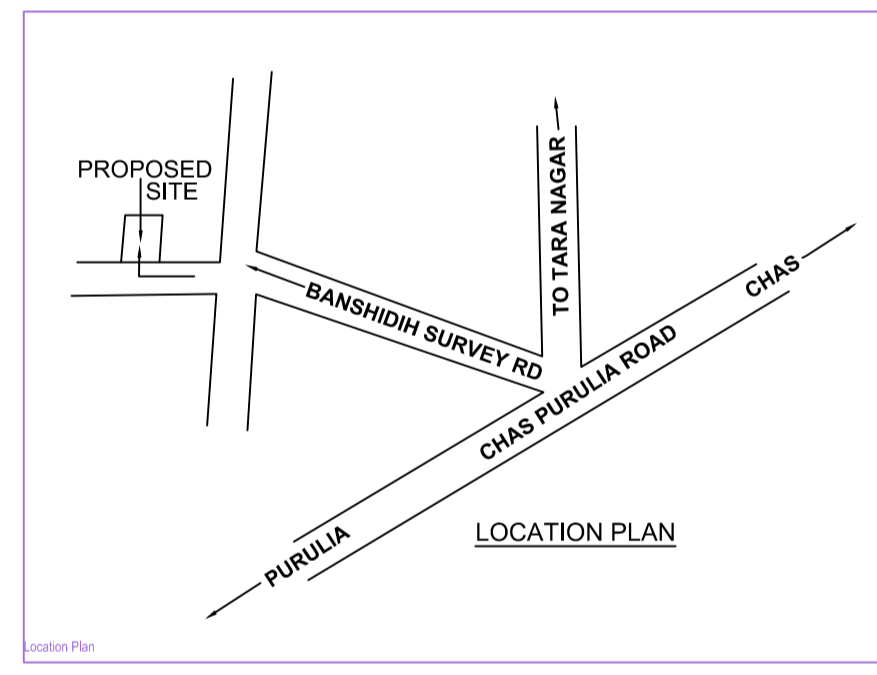
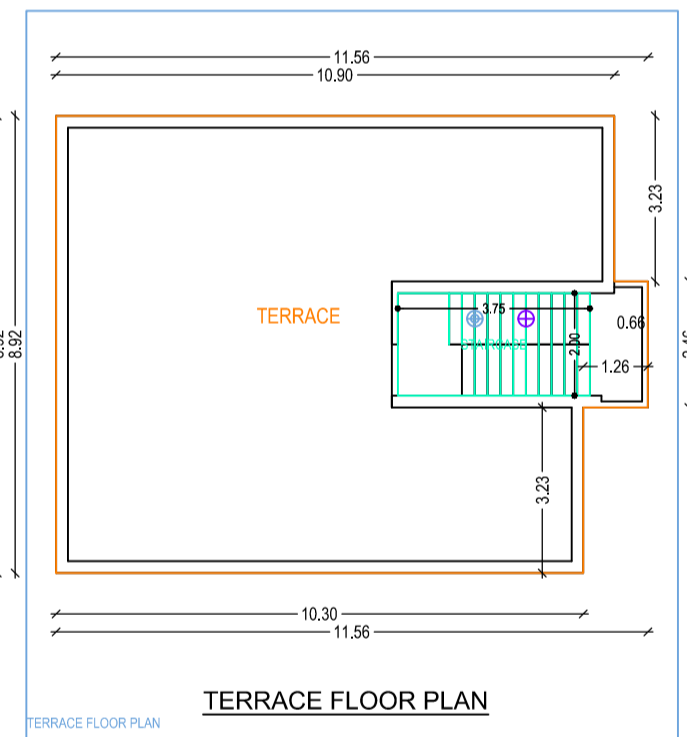
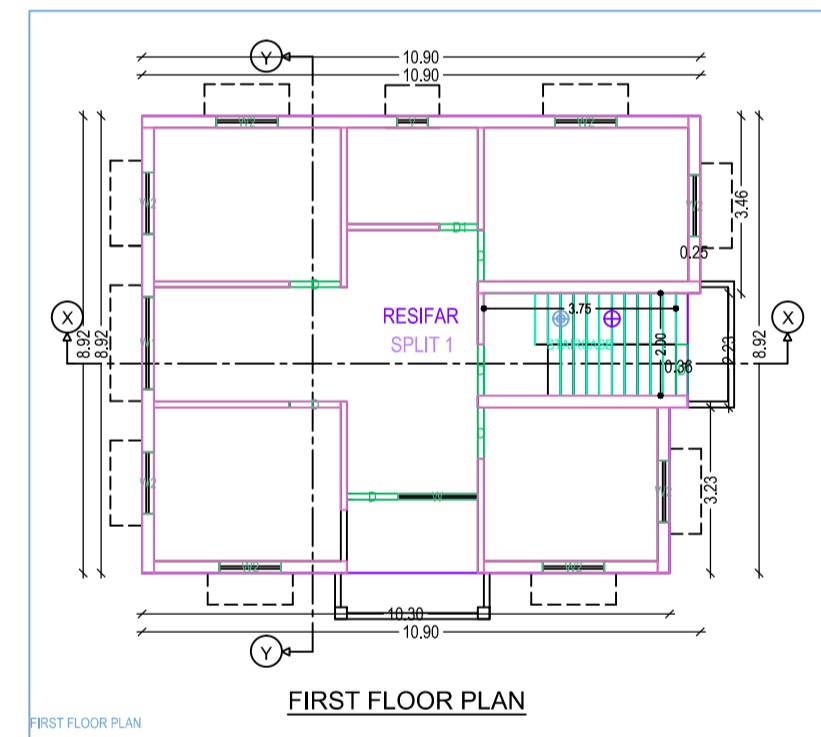
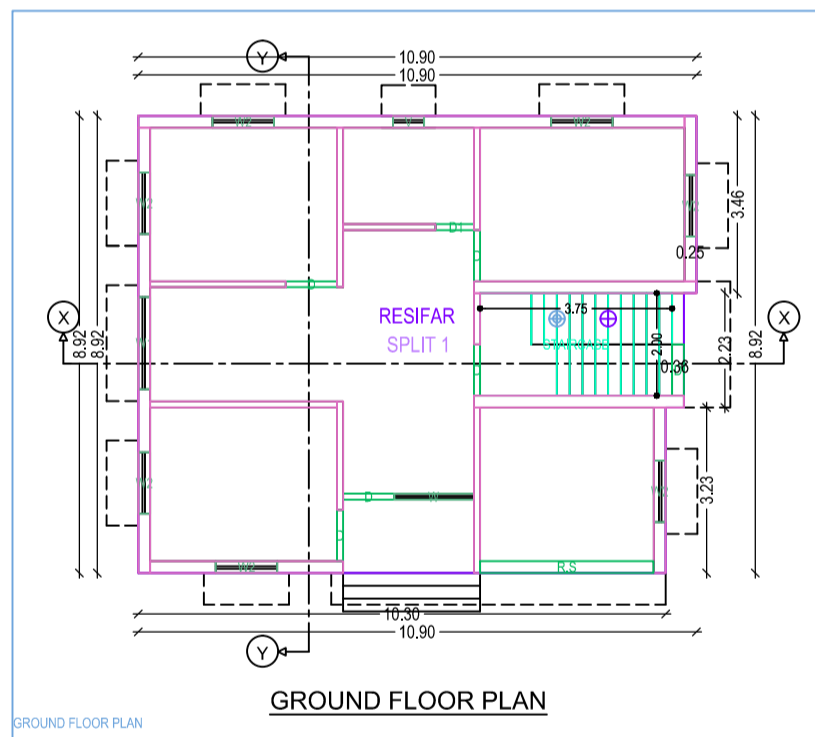
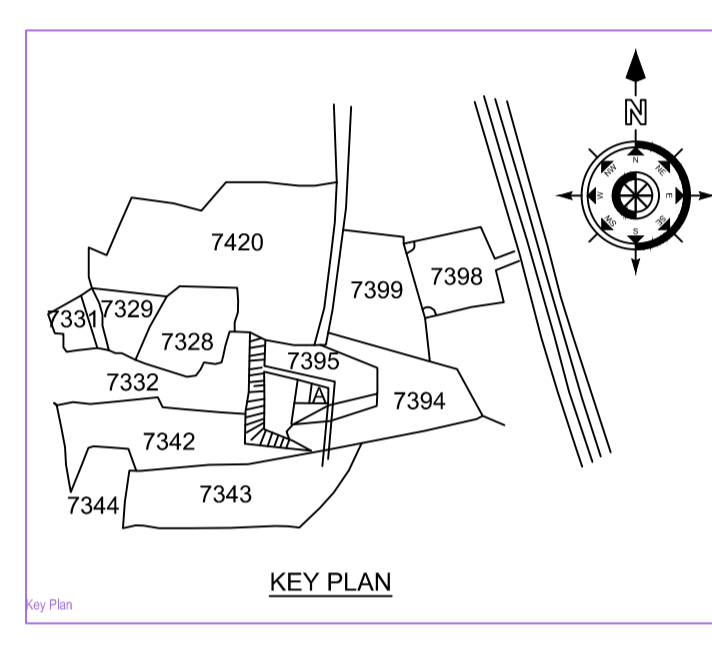
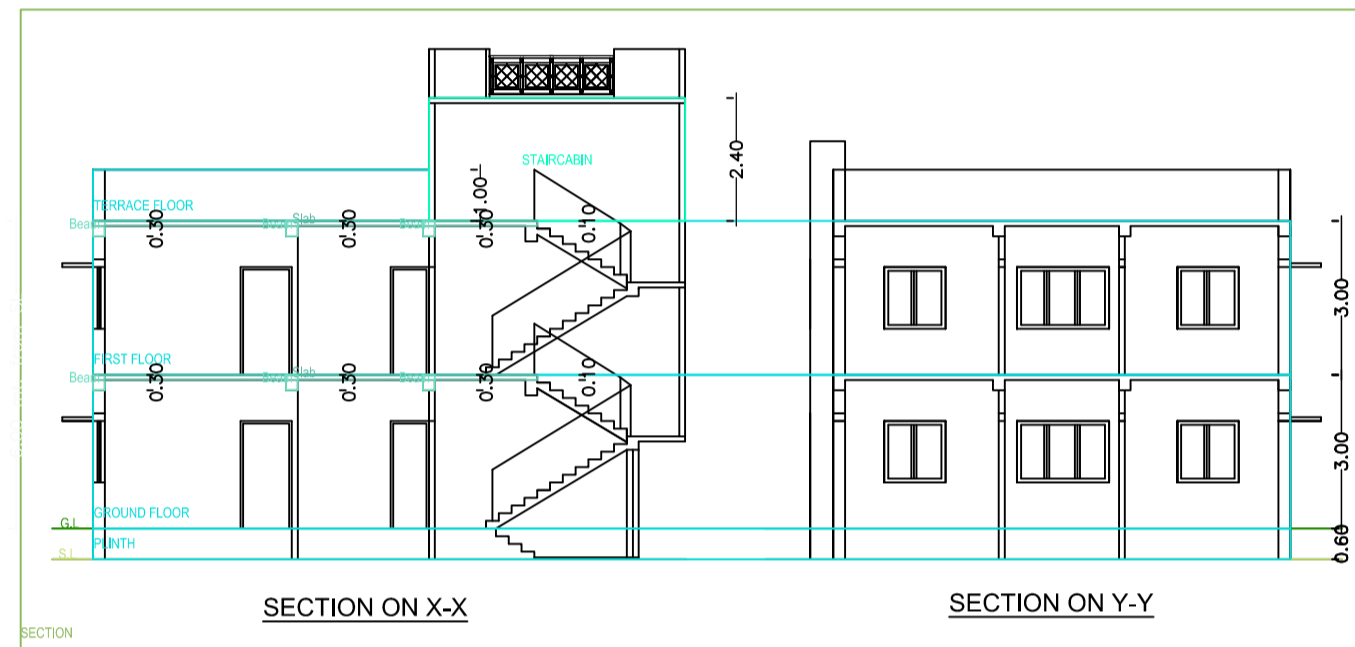
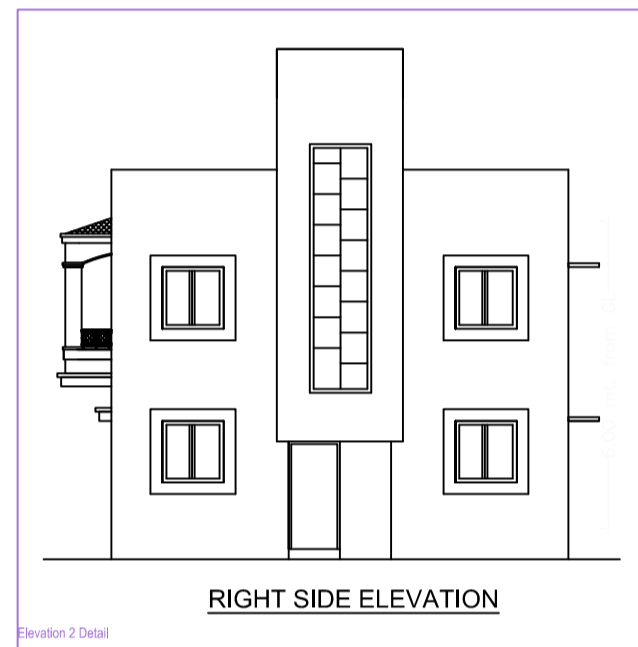
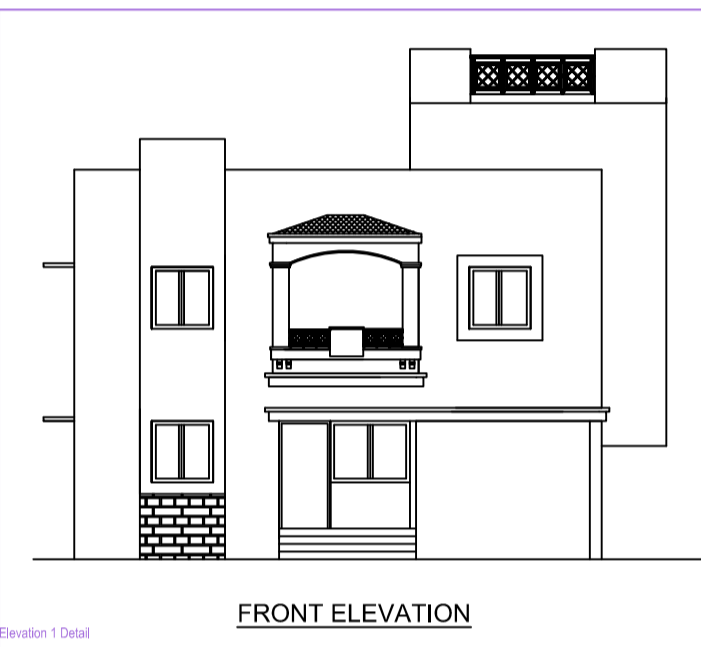
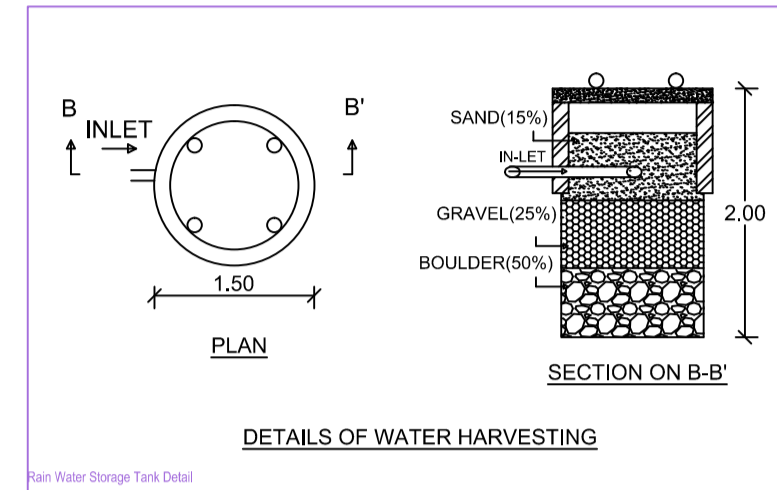
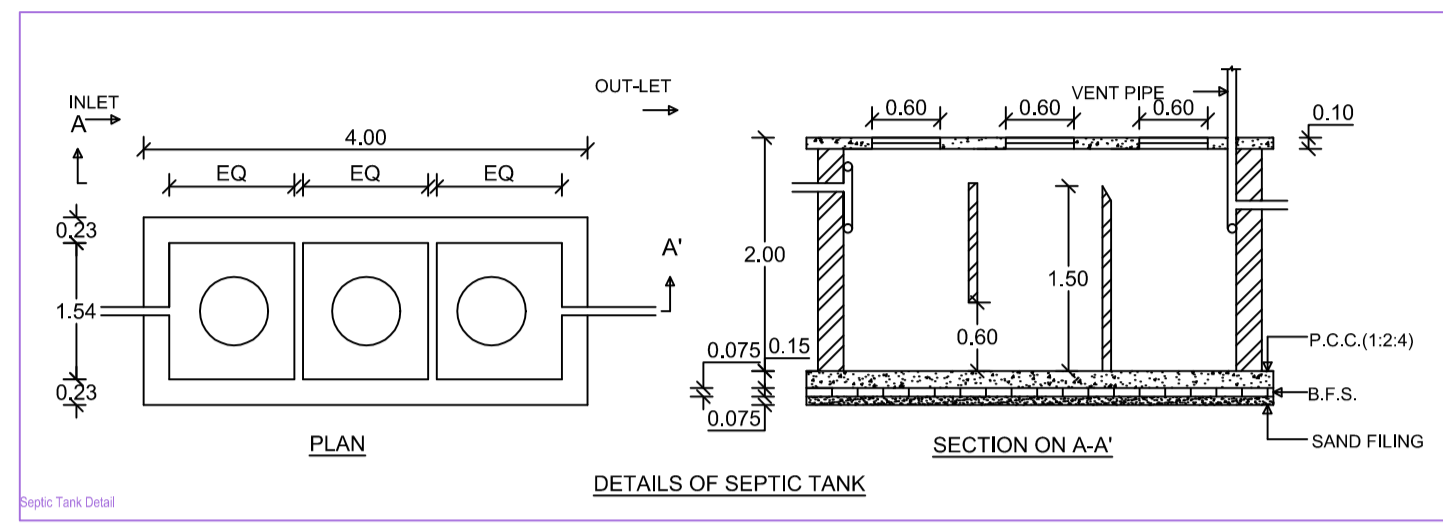
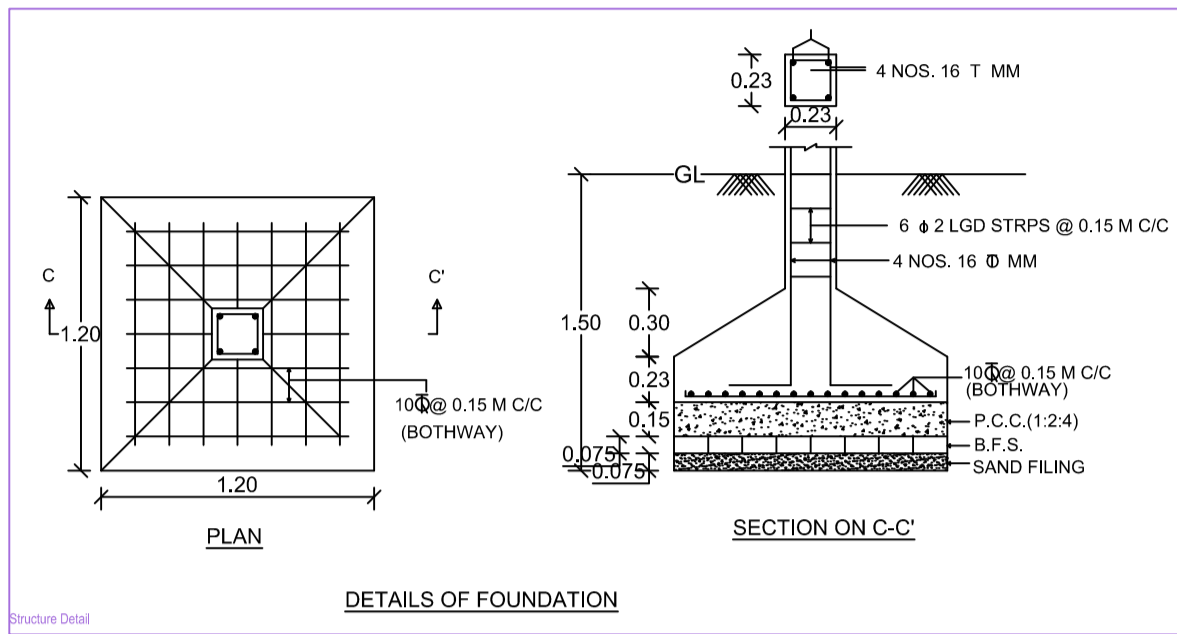

AREA STATEMENT: GRAS MUNICIPAL CORPORATION		VERSION NO.: 1.0.24
PROJECT DETAIL:		VERSION DATE: 01/01/2019
Project No.:	Plot Use: Residential	
Region: JHARKHAND URBAN LOCAL BODIES	Plot Sub-Use: Bungalow/ Dwelling / Non-Apartment	
District: BOKARO	Land Use Zone: NA	
Block/Zone Type: General Proposal	Abutting Road Width: -	
Project Type: Building Permission	Plot No.:	
Nature of Development: New	Revenue Survey No./Survey No.:	
Location: Old Area	Traverse No.:	
Sub-Location: NA	Block No.:	
Village/Mauza Name: -	Khata No.:	
Tract No.:	North -	
Road Street: -	South -	
	East -	
	West -	
AREA DETAILS:		SQ.MT.
AREA OF PLOT (Minimum)	(A)	156.49
Net Plot Area (Gross Plot Area - Deduction from Gross Plot area)	(A-Deductions)	156.49
Deductions for Balance Plot Area (from Gross Plot Area)		
COF Area		15.11
Total		15.11
Balance Plot Area (Net Plot Area - Recreational/Amenity space)	(A-Deductions)	140.37
Plot Area for Coverage (Net Plot Area)	(A-Deductions)	156.49
Plot Area for FSI (Net Plot Area + Road/Widening Area)	(A-Deductions)	156.49
Accessory Use Area		1.37
COVERAGE CHECK		
Proposed Coverage Area (60.53%)		94.72
Total Coverage Area (60.53%)		94.72
FAR CHECK		
Proposed Area of FAR		189.44
Total Area of FAR		189.44
BUILT UP AREA CHECK		
Total Proposed Built Up Area		189.44
ARCHITECT/SUPERVISOR (Regd)		OWNER
DEVELOPMENT AUTHORITY		LOCAL BODY

COLOR INDEX	
PLOT BOUNDARY	Black
ABUTTING ROAD	Red
PROPOSED WORK (COVERAGE AREA)	Green
EXISTING (To be retained)	Blue
EXISTING (To be demolished)	Yellow

MARGIN DETAIL:					
Building / W/O	Road Name	Front Margin	Rear Margin	Side Margin	Side Margin
A (MAMTA KUMARI)	3.65 M ROAD	2.00	1.50	0.90	0.90

FAR & Tenement Details (Table 4c-1)					
Building	No. of Same Bldg	Total Built Up Area (Sq.Mt.)	Proposed FAR Area (Sq.Mt.)	Total FAR Area (Sq.Mt.)	Tenr (No.)
A (MAMTA KUMARI)	1	189.44	189.44	189.44	01
Grand Total	1	189.44	189.44	189.44	01

A (MAMTA KUMARI)

Building 'A' (MAMTA KUMARI)

Floor Name	Total Built Up Area (Sq.Mt.)	Proposed FAR Area (Sq.Mt.)	Total FAR Area (Sq.Mt.)	Tenr (No.)
Ground Floor...	94.72	94.72	94.72	01
First Floor...	94.72	94.72	94.72	01
Terrace Floor...	0.00	0.00	0.00	00
Total	189.44	189.44	189.44	01
Total Number of Same Buildings	1			
Total	189.44	189.44	189.44	01

SCHEDULE OF JOINERY:

BUILDING NAME	NAME	LENGTH	HEIGHT	NOS
A (MAMTA KUMARI)	D1	0.75	2.10	02
A (MAMTA KUMARI)	D2	1.00	2.10	13
A (MAMTA KUMARI)	R-3	3.39	2.10	01
Total	-	-	-	16

SCHEDULE OF JOINERY:

BUILDING NAME	NAME	LENGTH	HEIGHT	NOS
A (MAMTA KUMARI)	V	0.60	1.50	02
A (MAMTA KUMARI)	W2	1.20	1.20	16
A (MAMTA KUMARI)	W1	1.50	1.20	02
A (MAMTA KUMARI)	W1	1.80	1.20	02
Total	-	-	-	21

UnitBUA Table for Building 'A' (MAMTA KUMARI)

FLOOR	Name	UnitBUA Type	UnitBUA Area	Carpet Area	No. of Rooms	No. of Tenement
GROUND FLOOR PLAN	SPLIT 1	FLAT	189.44	166.76	7	1
Total	-	-	189.44	166.76	14	1