

Proposal Basic Information

Proposal File No.	CMC/BP/0205/W19/2020
Owner Name	SAVITRI DEVI
Khata No	108
Plot No	5290
Village Name	Chas
Use	Residential
SubUse	Bungalow/ Dwelling / Non Apartment

AREA STATEMENT CHAS MUNICIPAL CORPORATION

VERSION NO. : 1.0.61
VERSION DATE: 16/10/2020

PROJECT DETAIL:

Region: JHARKHAND URBAN LOCAL BODIES	Plot Use: Residential
District: BOKARO	Plot SubUse: Bungalow/ Dwelling / Non Apartment
Authority: CHAS MUNICIPAL CORPORATION	PlotNearbyReligiousStructure: NA
Inward No: CMC/BP/0205/W19/2020	PlotSubPlot No: 5290
Application Type: General Proposal	North: CTS No. - PART OF PLOT
Project Type: Building Permission	South: CTS No. - 6.1
Nature of Development: New	East: Plot No. - 5290
Location of Development Area: Old Area	West: Plot No. - 5290

AREA DETAILS:

AREA OF PLOT (Minimum)	(A)	SQ.MT.	96.62
NET AREA OF PLOT(Gross Plot Area - Deduction from Gross Plot area)	(A-Deductions)		96.62
Deduction for Balance Plot Area(from Gross Plot Area)			
Common Plot			22.61
Total			22.61
BALANCE AREA OF PLOT(Net Plot Area - Recreational/Amenity space)	(A-Deductions)		74.01
PLOT AREA FOR COVERAGE(Net Plot Area)	(A-Deductions)		96.62
Plot Area for FAR (Net Plot Area + Road Widening Area)	(A-Deductions)		96.62
COVERAGE CHECK			
Permissible Coverage area (70.00 %)			67.63
Proposed Coverage Area (32.89 %)			31.78
Total Prop. Coverage Area (32.89 %)			31.78
Balance coverage area (37.11 %)			35.85
FAR CHECK			
Perm. FAR Area (1.80)			173.92
Total Perm. FAR area			173.92
Residential FAR			63.56
Proposed FAR Area			72.06
Total Proposed FAR Area			72.06
Consumed FAR (Factor)			0.75
Balance FAR Area			101.86
BUILT UP AREA CHECK			
Total Proposed BuiltUp Area			85.59
ARCHITECT (Regd)		Mukesh Kumar	
ENGINEER (Regd)			
SUPERVISOR (Regd)			
OWNER (Regd)		SAVITRI DEVI	
DEVELOPMENT AUTHORITY		LOCAL BODY	

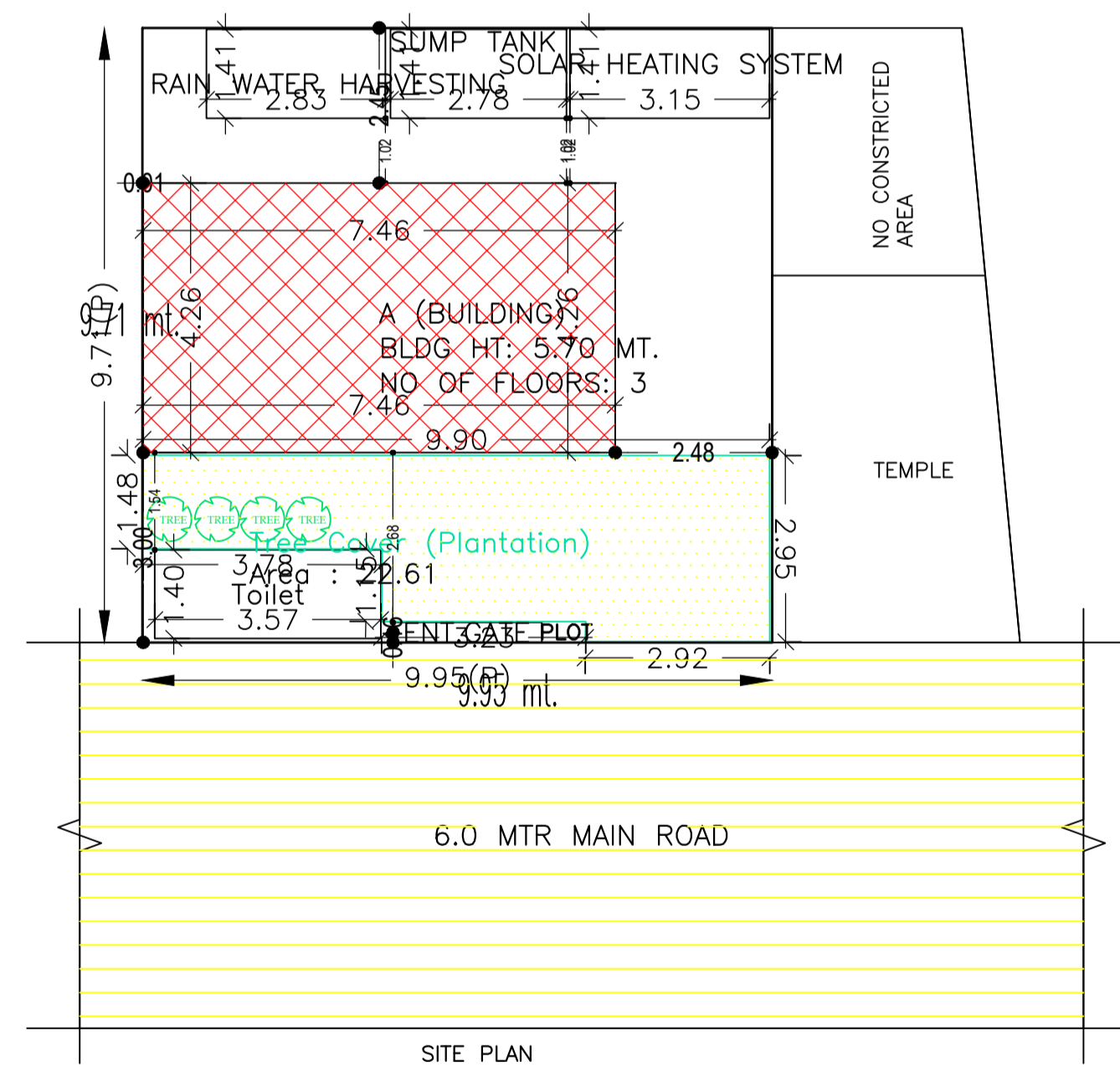
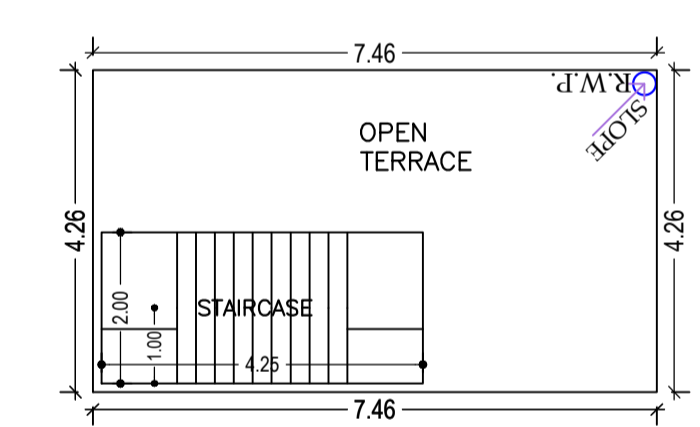
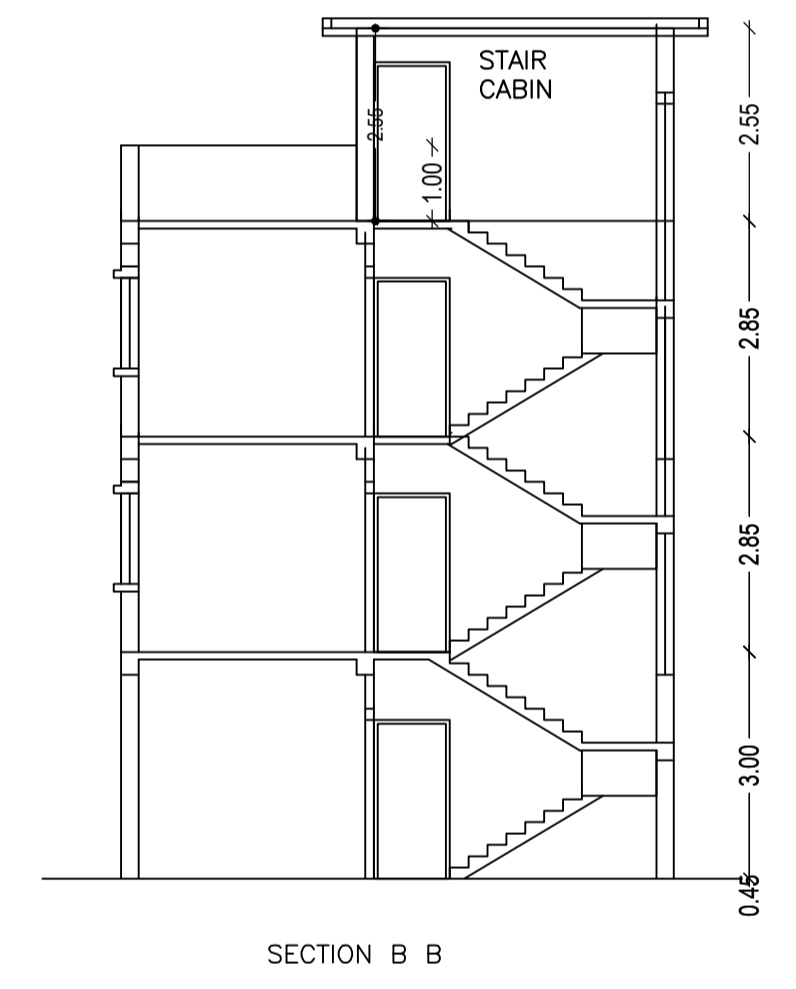
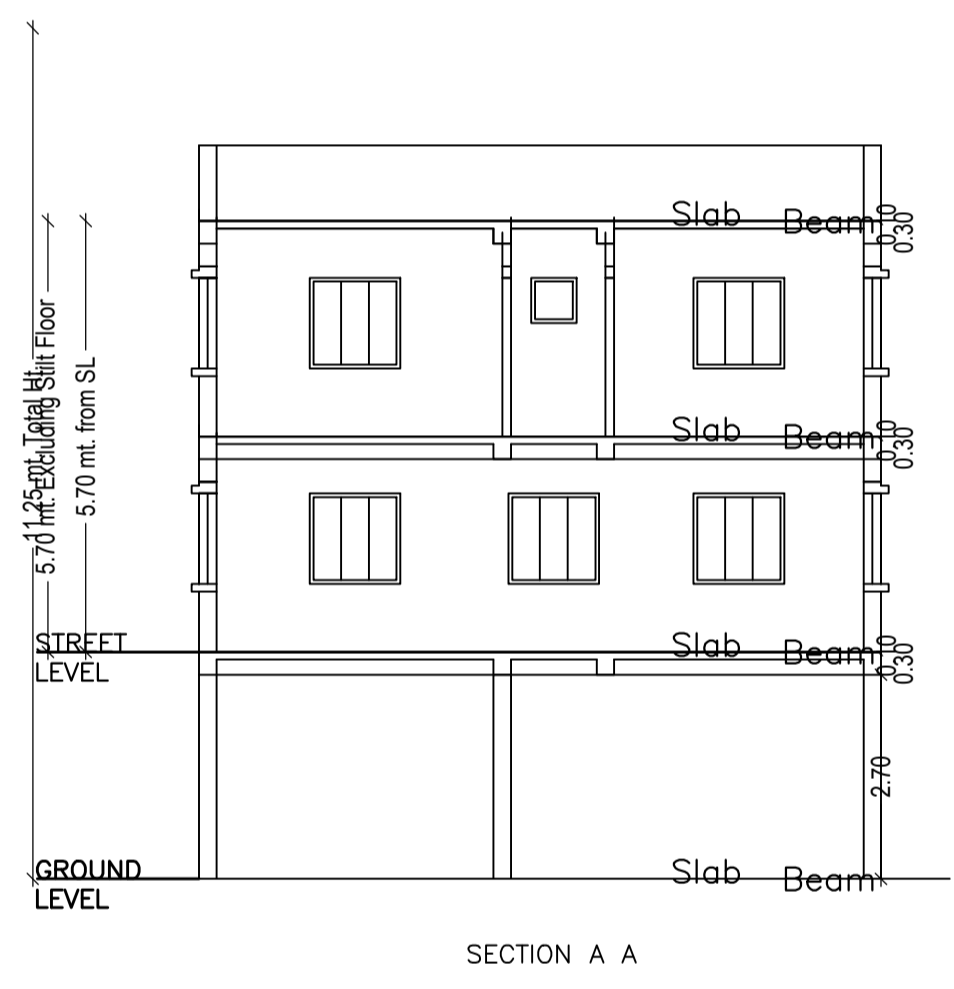
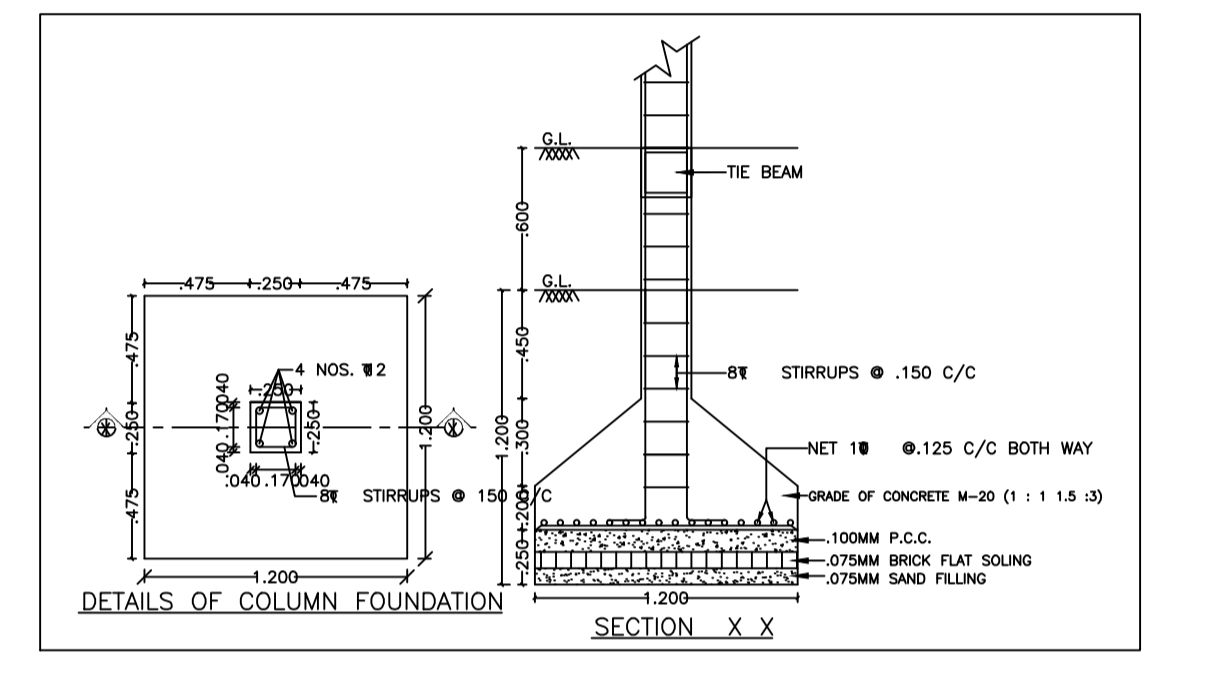
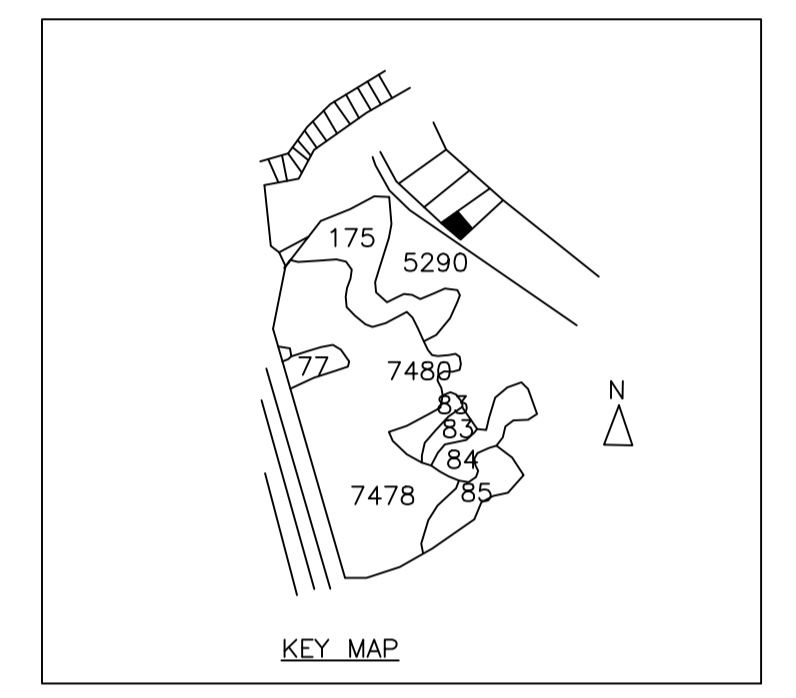

FAR & Tenement Details (Table 4c-1)

Building	No. of Same Bldg	Total Built Up Area (Sq.mt.)	Deductions (Area in Sq.mt.)	Proposed FAR Area (Sq.mt.)	Add Area In FAR (Sq.mt.)	Total FAR Area (Sq.mt.)	Total Consumed Additional FAR Area (Sq.mt.)	Trmt (No.)
A (BUILDING)	1	85.59	13.53	63.56	8.50	72.06	72.06	01
Grand Total :	1	85.59	13.53	63.56	8.50	72.06	72.06	01

Buildingwise Floor FAR Details

Floor Name	Building Name		Total	
	Proposed Built Up Area (Sq.mt.)	Proposed FAR Area (Sq.mt.)	Total Proposed Built Up Area (Sq.mt.)	Total FAR Area (Sq.mt.)
Stilt Floor	22.03	8.50	22.03	8.50
Ground Floor	31.78	31.78	31.78	31.78
First Floor	31.78	31.78	31.78	31.78
Terrace Floor	0.00	0.00	0.00	0.00
Total :	85.59	72.06	85.59	72.06

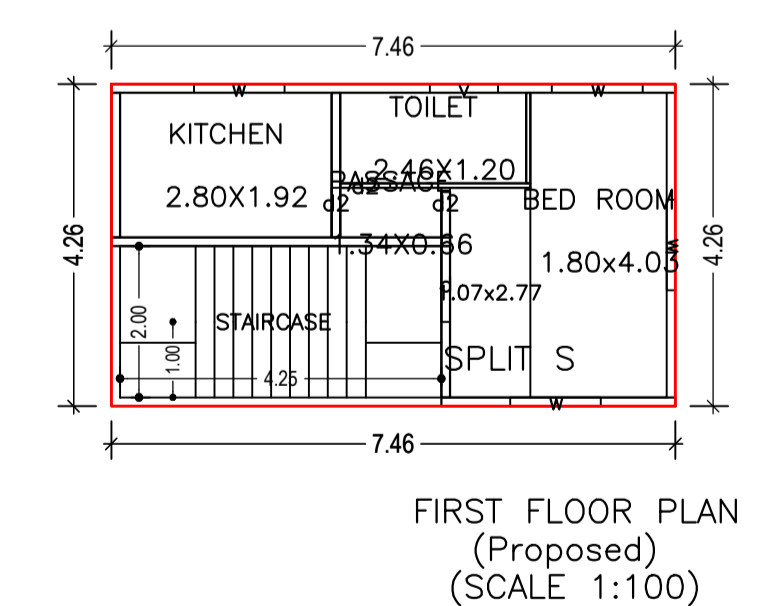
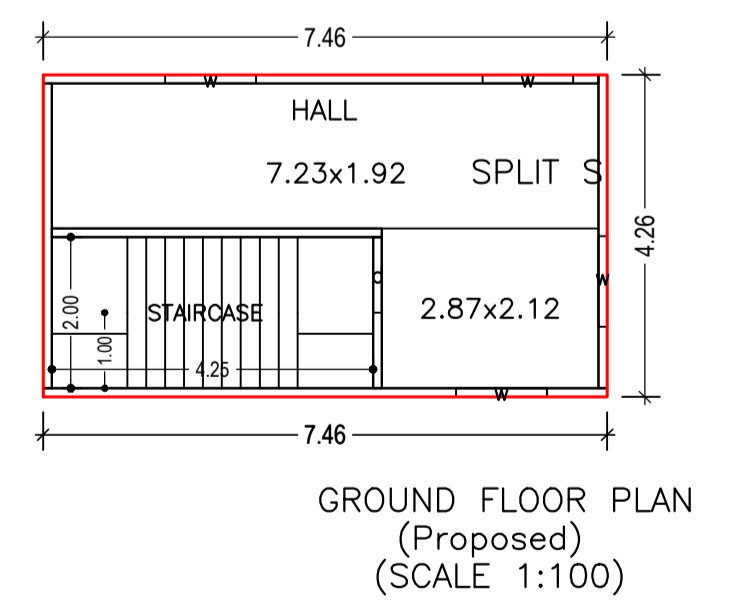
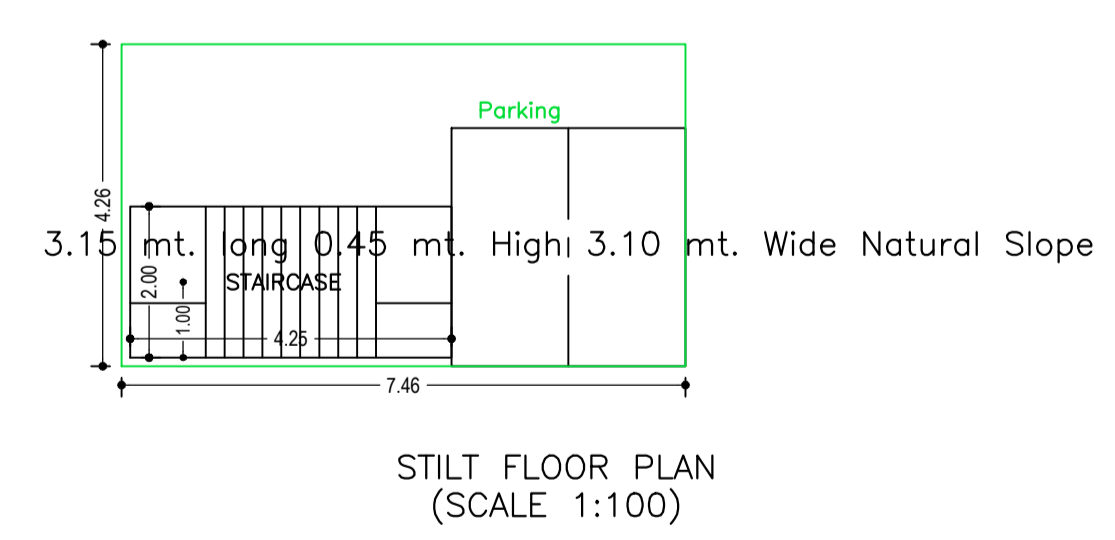

Building :A (BUILDING)

Floor Name	Total Built Up Area (Sq.mt.)	Deductions (Area in Sq.mt.)	Proposed FAR Area (Sq.mt.)	Add Area In FAR (Sq.mt.)	Total FAR Area (Sq.mt.)	Total Consumed Additional FAR Area (Sq.mt.)	Trmt (No.)
Stilt Floor	22.03	13.53	0.00	8.50	8.50	8.50	00
Ground Floor	31.78	0.00	31.78	0.00	31.78	31.78	01
First Floor	31.78	0.00	31.78	0.00	31.78	31.78	00
Terrace Floor	0.00	0.00	0.00	0.00	0.00	0.00	00
Total :	85.59	13.53	63.56	8.50	72.06	72.06	01

LTP NAME AND SIGNATURE

Mukesh Kumar
CMC/ENG/0004/2017

STRUCTURAL ENG'S NAME AND SIGNATURE

BUILDER NAME AND SIGNATURE

DIGITAL SIGNATURE

SCHEDULE OF DOOR:

BUILDING NAME	NAME	LENGTH	HEIGHT	NOS
A (BUILDING)	d2	0.66	2.10	03
A (BUILDING)	d	1.00	2.10	02

SCHEDULE OF WINDOW/VENTILATION:

BUILDING NAME	NAME	LENGTH	HEIGHT	NOS
A (BUILDING)	v	0.90	0.60	01
A (BUILDING)	w	1.20	1.50	08

Building USE/SUBUSE Details

Building Name	Building Use	Building SubUse	Building Structure
A (BUILDING)	Residential	Bungalow/ Dwelling / Non Apartment	Non-Highrise

COLOR INDEX

PLOT BOUNDARY	Black
ABUTTING ROAD	Red
PROPOSED CONSTRUCTION	Green
COMMON PLOT	Yellow
ROAD WIDENING AREA	Blue
EXISTING (To be retained)	Orange
EXISTING (To be demolished)	Purple