

Proposal Basic Information

Proposal File No.	CMC/BP/0189/W04/2020
Owner Name	RAJEEV RANJAN SAHAY
Khata No	149
Plot No	1698
Village Name	Chas
Use	Residential
SubUse	Bungalow/ Dwelling / Non Apartment

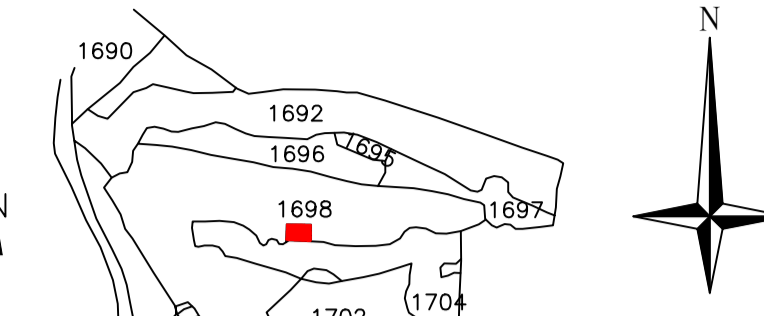

AREA STATEMENT CHAS MUNICIPAL CORPORATION	VERSION NO: 1.0.52	SQ. MT.
PROJECT DETAIL:	VERSION DATE: 16/10/2020	
Region: JHARKHAND URBAN LOCAL BODIES	Plot Use: Residential	
District: BOKARO	Plot SubUse: Bungalow/ Dwelling / Non Apartment	
Authority: CHAS MUNICIPAL CORPORATION	PlotNearbyReligiousStructure: NA	
Inward No: CMC/BP/0189/W04/2020	PlotSubPlot No: 1698	
Application Type: General Proposal	North: CTS No. - PLOT MARK A/1/25	
Project Type: Building Permission	South: CTS No. - PLOT MARK A/1/27	
Nature of Development: New	East: Road Width - 3.65	
Location of Development Area: Old Area	West: CTS No. - PLOT MARK A/1/14	
AREA DETAILS:		
AREA OF PLOT (Minimum)	(A)	185.27
NET AREA OF PLOT(Gross Plot Area - Deduction from Gross Plot area)	(A-Deductions)	185.27
Deduction for Balance Plot Area(from Gross Plot Area)		
Common Plot		28.44
Total		28.44
BALANCE AREA OF PLOT(Net Plot Area - Recreational/Amenity space)	(A-Deductions)	156.84
PLOT AREA FOR COVERAGE(Net Plot Area)	(A-Deductions)	185.27
Plot Area for FAR (Net Plot Area + Road Widening Area)	(A-Deductions)	185.27
COVERAGE CHECK		
Permissible Coverage area (70.00 %)		129.69
Proposed Coverage Area (55.39 %)		102.62
Total Prop. Coverage Area (55.39 %)		102.62
Balance coverage area (14.61 %)		27.07
FAR CHECK		
Perm. FAR Area (2.50)		463.18
Total Perm. FAR area		463.18
Residential FAR		330.73
Proposed FAR Area		330.73
Total Proposed FAR Area		330.73
Consumed FAR (Factor)		1.79
Balance FAR Area		132.45
BUILT UP AREA CHECK		
Total Proposed BuiltUp Area		330.74
ARCHITECT (Regd)	Mukesh Kumar	
ENGINEER (Regd)		
SUPERVISOR (Regd)		
OWNER (Regd)	RAJEEV RANJAN SAHAY	
DEVELOPMENT AUTHORITY	LOCAL BODY	

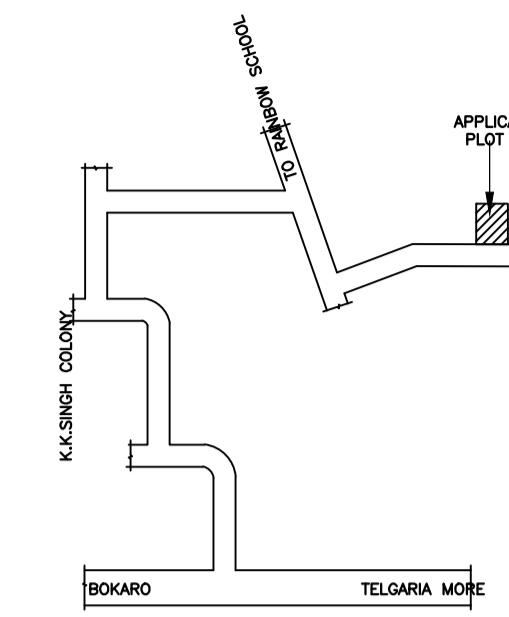
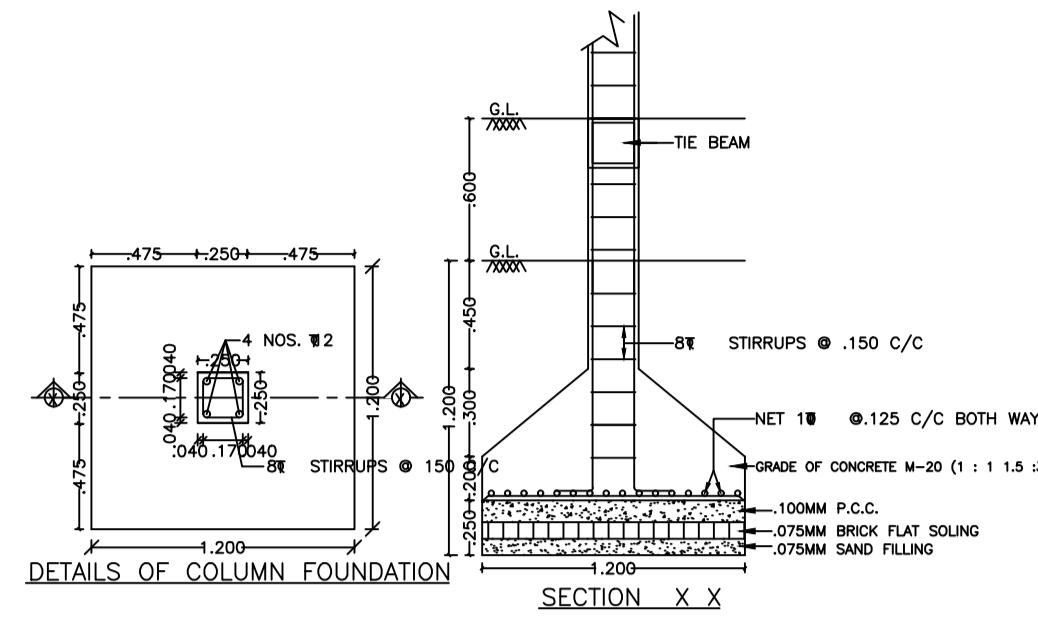
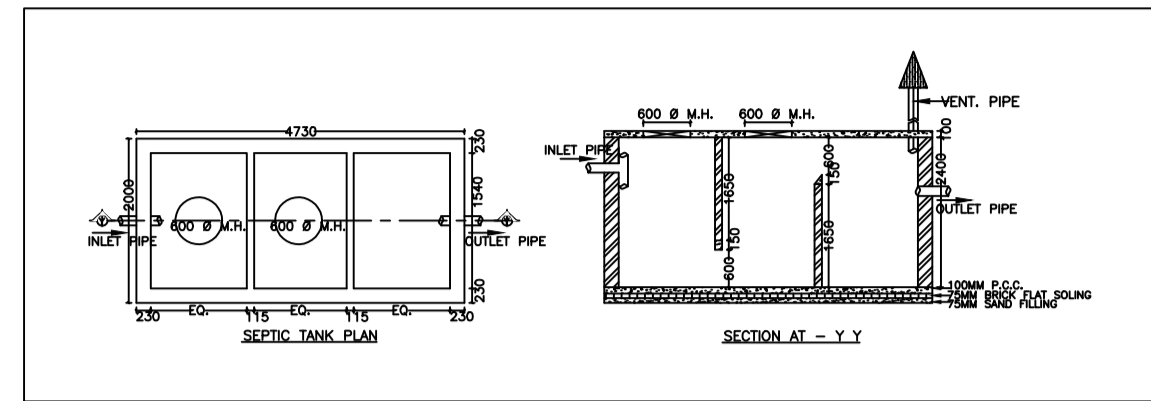
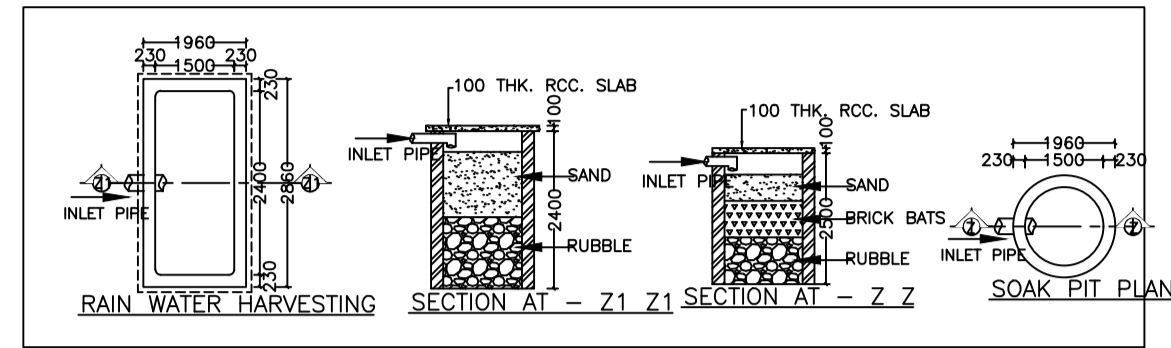
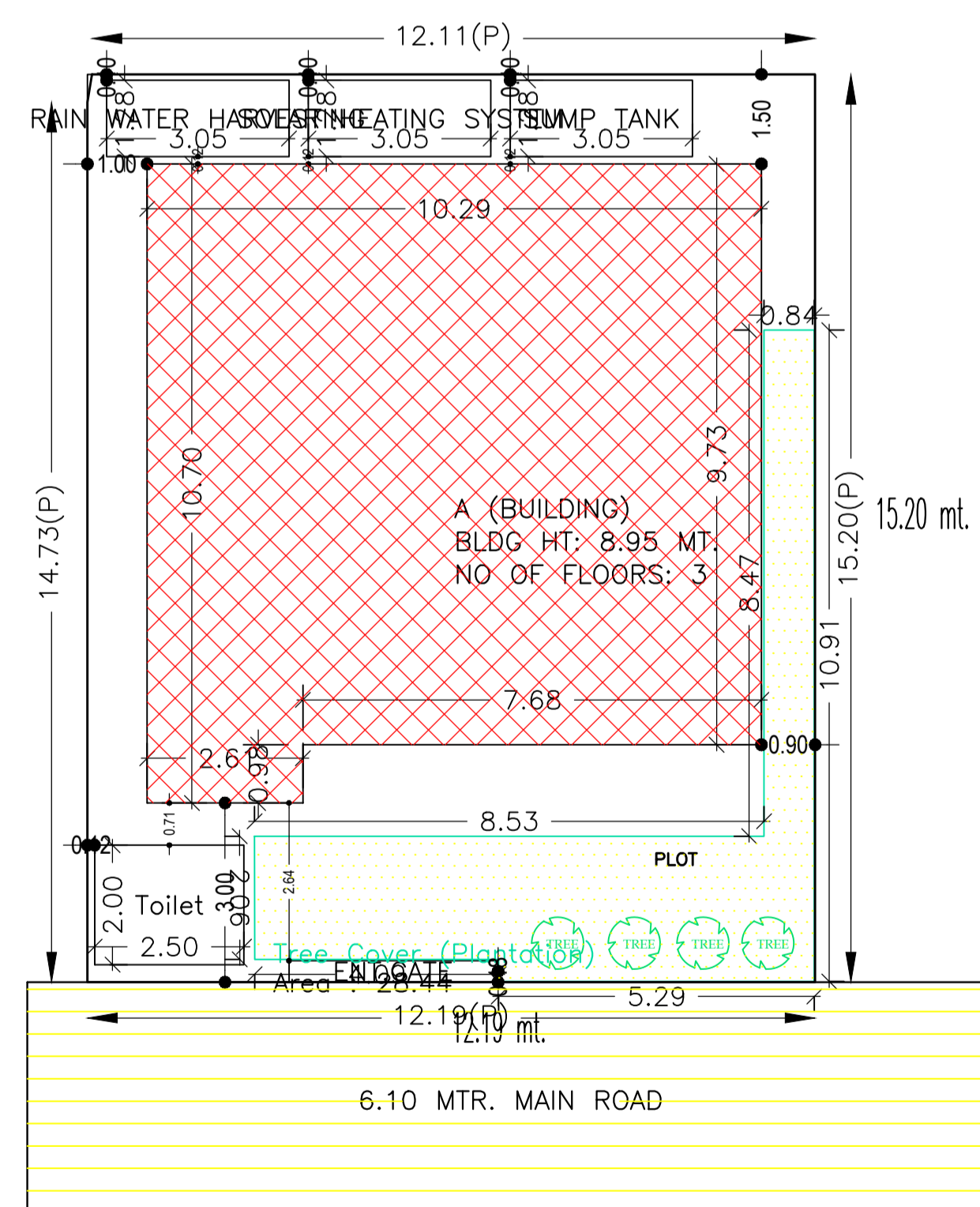
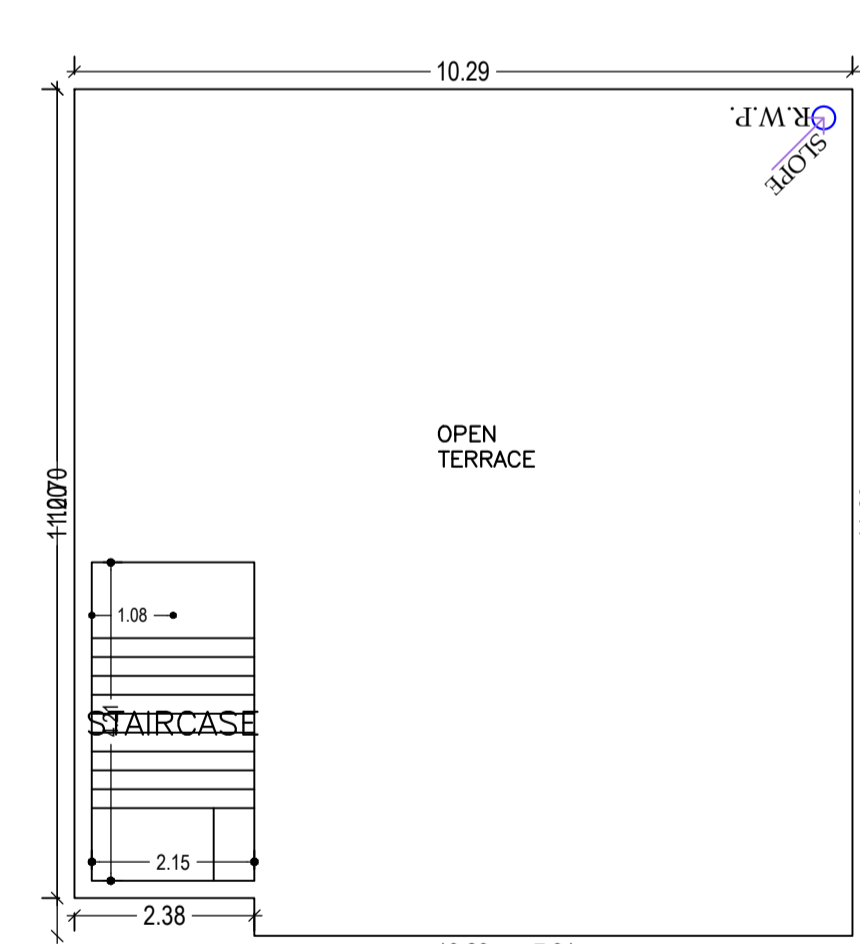
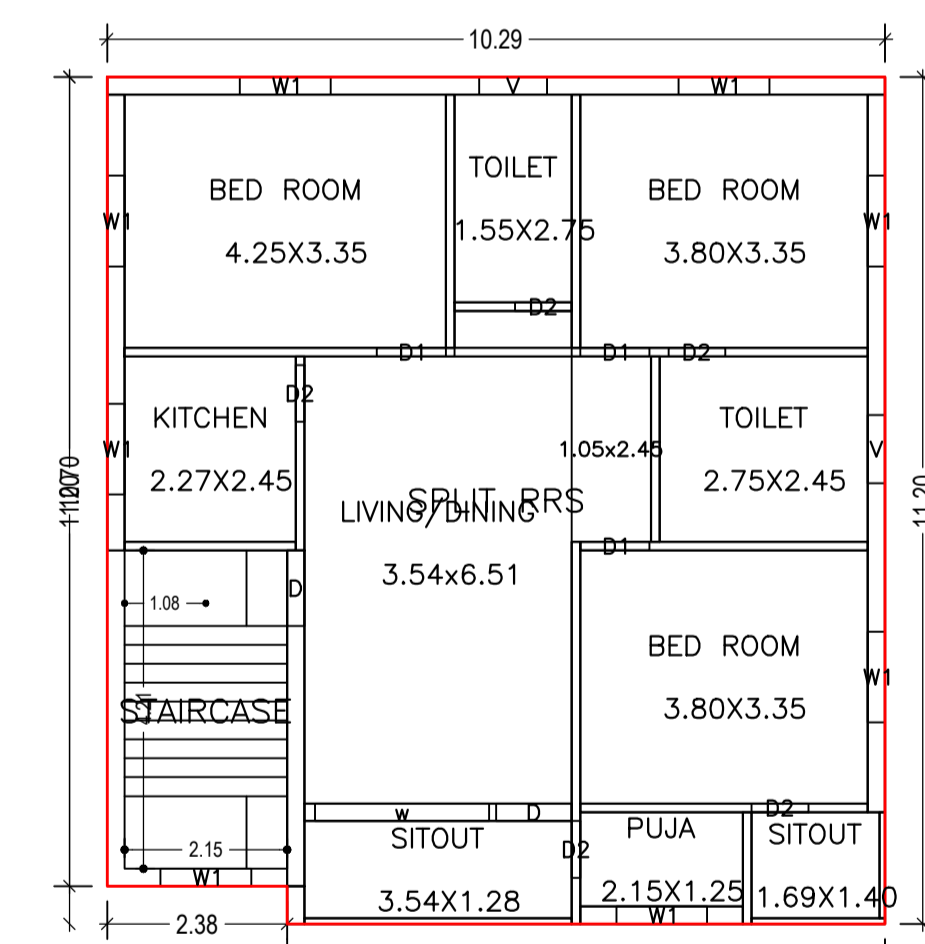
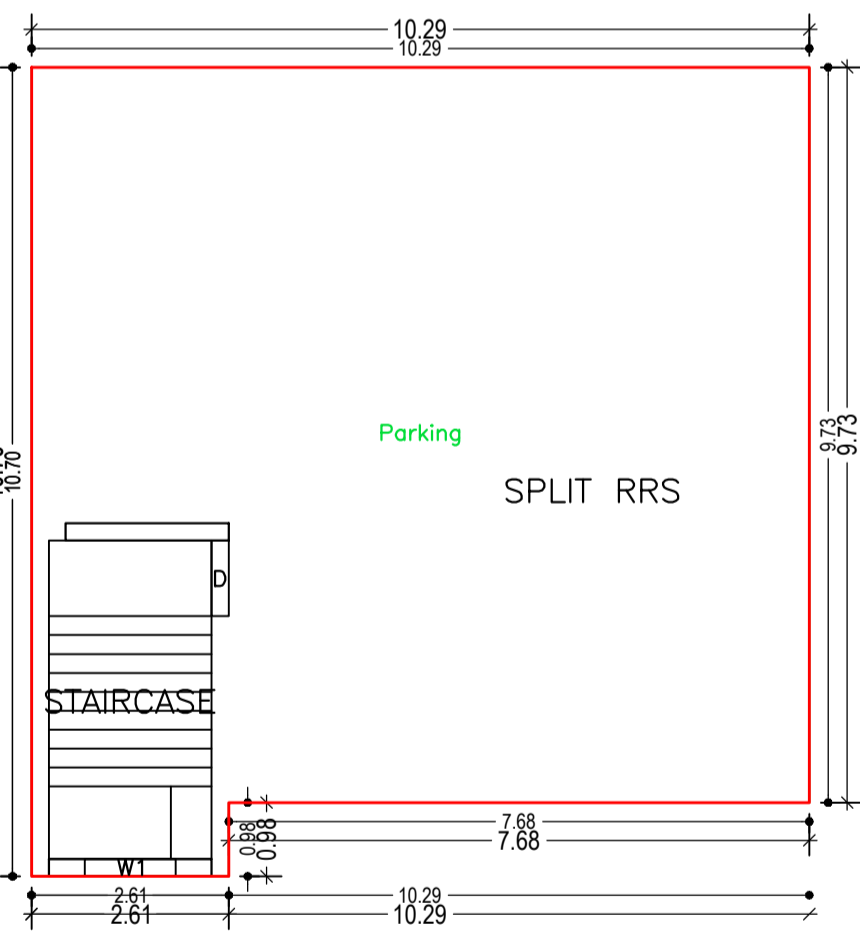
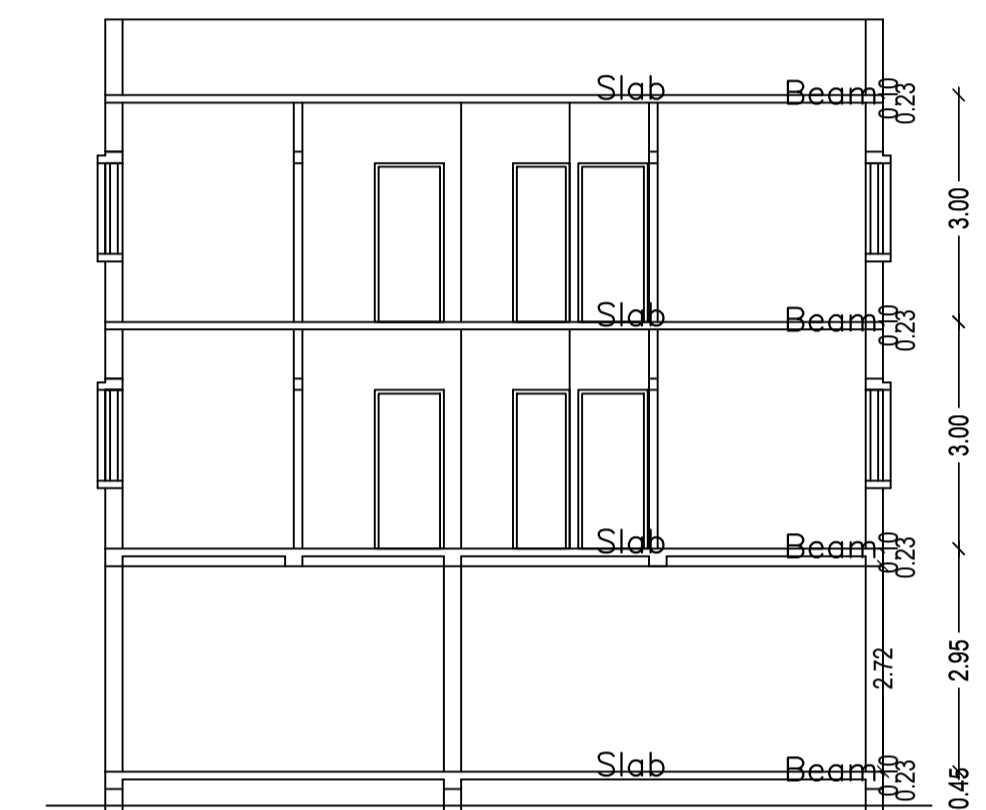
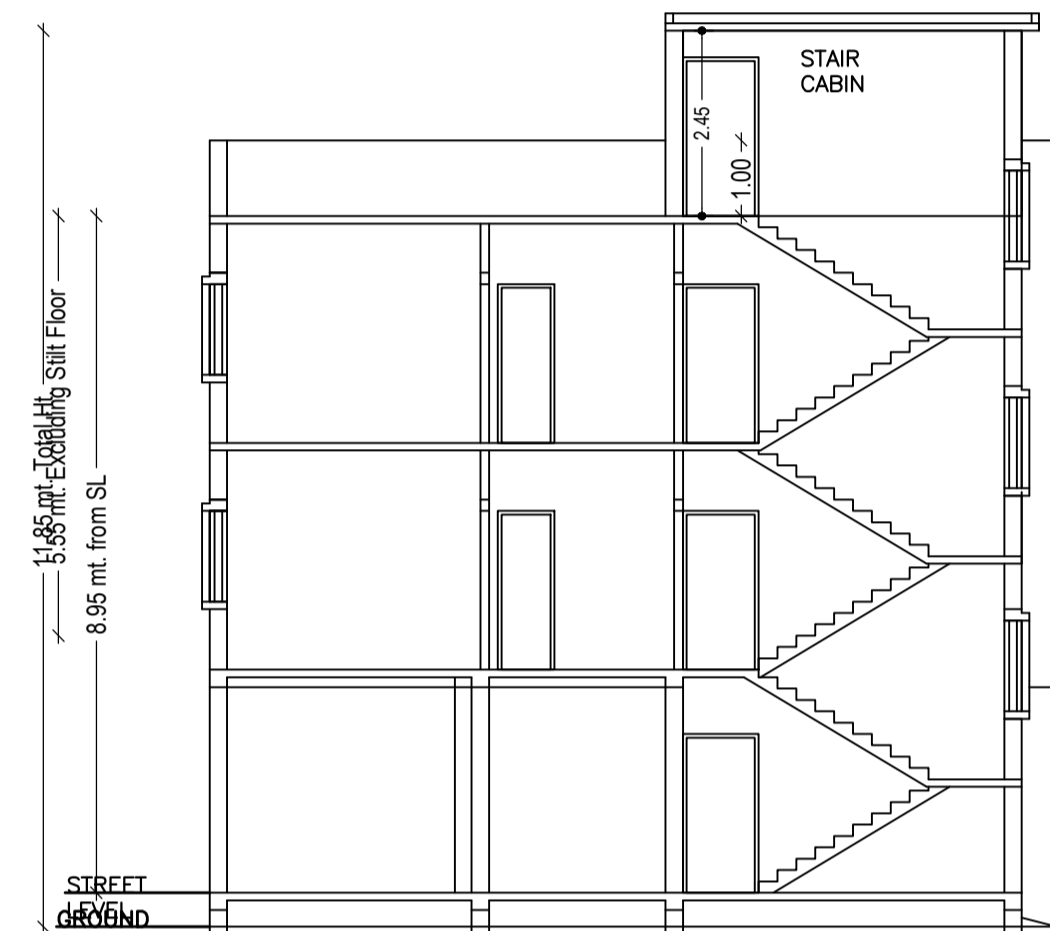
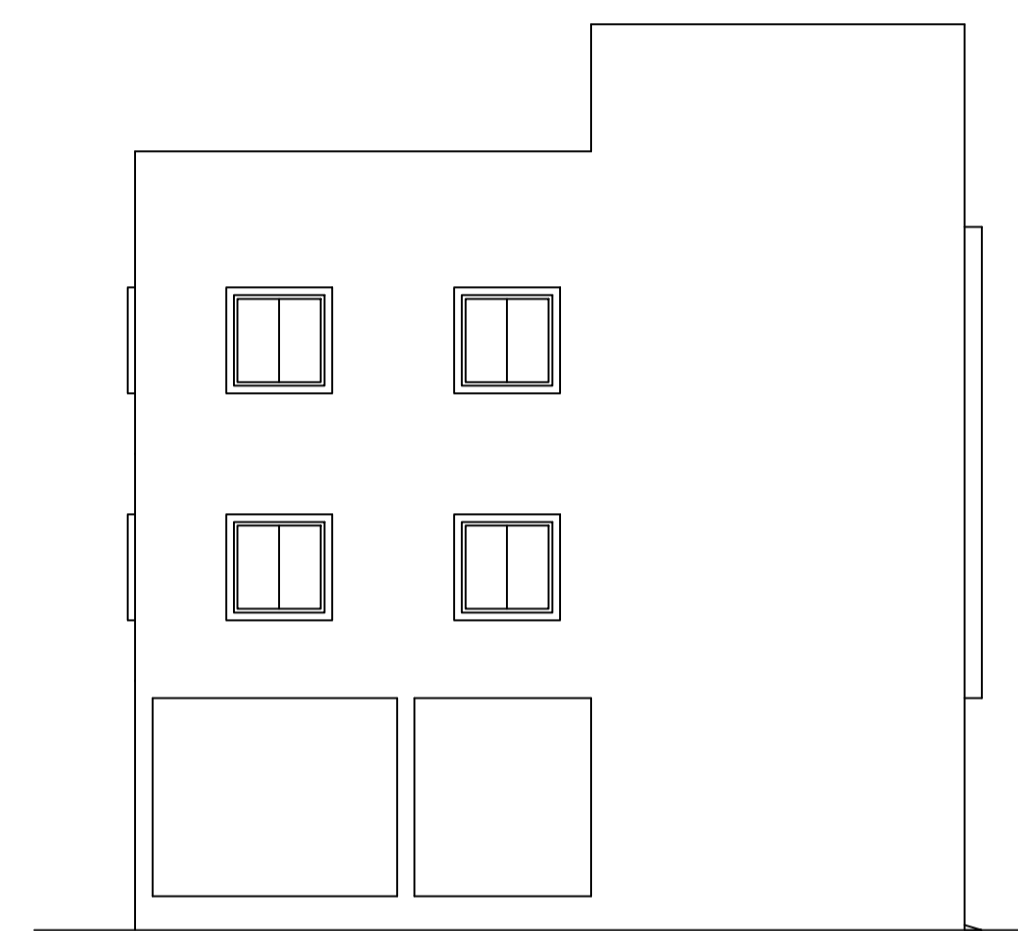
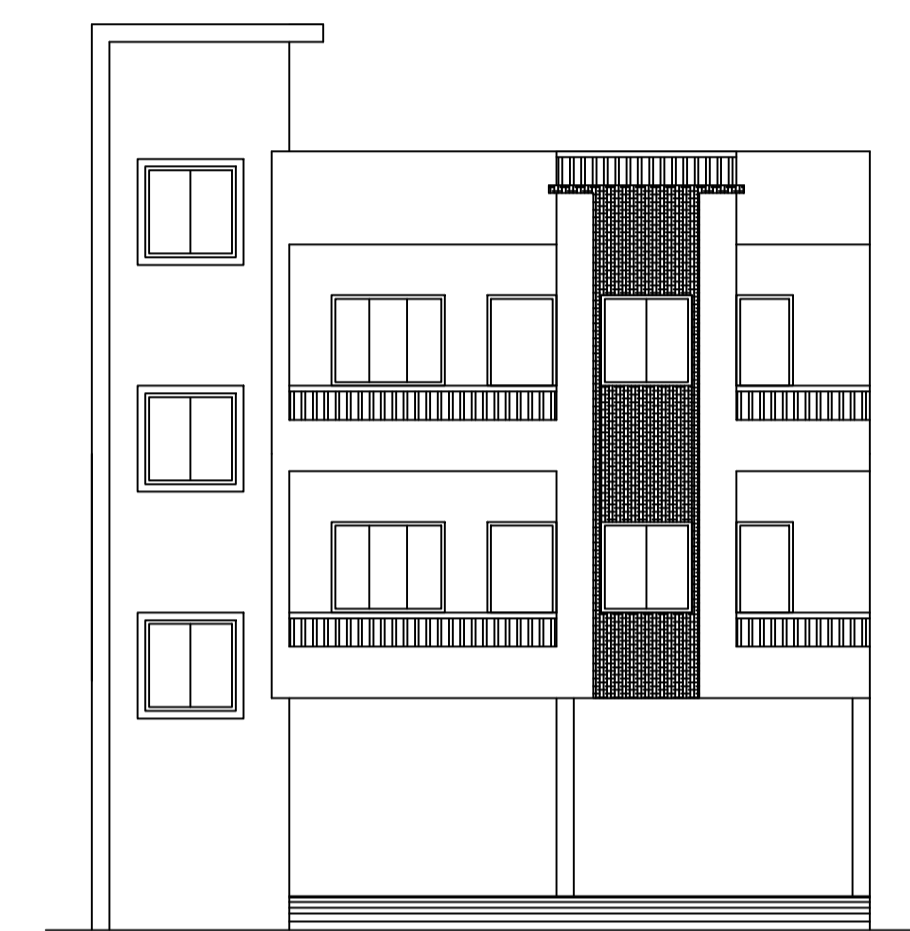

Building :A (BUILDING)

Floor Name	Total Built Up Area (Sq.mt.)	Proposed FAR Area (Sq.mt.) Resi.	Total FAR Area (Sq.mt.)	Total Consumed Additional FAR Area (Sq.mt.)	Tnmt (No.)
Stilt Floor	102.62	102.62	102.62	102.62	01
First Floor	114.06	114.06	114.06	114.06	00
Second Floor	114.06	114.06	114.06	114.06	00
Terrace Floor	0.00	0.00	0.00	0.00	00
Total :	330.74	330.74	330.74	330.74	01
Total Number of Same Buildings	1				
Total :	330.74	330.74	330.74	330.74	01

Buildingwise Floor FAR Details

Floor Name	Building Name A (BUILDING)		Total	
	Proposed Built Up Area (Sq.mt.)	Proposed FAR Area (Sq.mt.)	Total Proposed Built Up Area (Sq.mt.)	Total FAR Area (Sq.mt.)
Stilt Floor	102.62	102.62	102.62	102.62
First Floor	114.06	114.06	114.06	114.06
Second Floor	114.06	114.06	114.06	114.06
Terrace Floor	0.00	0.00	0.00	0.00
Total :	330.74	330.74	330.74	330.74

COLOR INDEX

PLOT BOUNDARY	Black
ABUTTING ROAD	Red
PROPOSED CONSTRUCTION	Green
COMMON PLOT	Yellow
ROAD WIDENING AREA	Orange
EXISTING (To be retained)	Blue
EXISTING (To be demolished)	Light Blue

SCHEDULE OF DOOR:

BUILDING NAME	NAME	LENGTH	HEIGHT	NOS
A (BUILDING)	D2	0.75	2.10	10
A (BUILDING)	D1	0.92	2.10	06
A (BUILDING)	D	1.00	2.10	04

SCHEDULE OF WINDOW/VENTILATION:

BUILDING NAME	NAME	LENGTH	HEIGHT	NOS
A (BUILDING)	V	0.90	0.60	04
A (BUILDING)	W1	1.20	1.20	16
A (BUILDING)	w	2.30	2.10	02

UnitBUA Table for Building :A (BUILDING)

FLOOR	Name	UnitBUA Type	UnitBUA Area	Carpet Area	No. of Rooms	No. of Tenement
STILT FLOOR PLAN	SPLIT RRS	FLAT	292.80	283.71	0	1
TYPICAL - 1 & 2 FLOOR PLAN	SPLIT RRS	FLAT	0.00	0.00	10	0
Total:	-	-	292.80	283.71	20	1

FAR & Tenement Details (Table 4c-1)

Building	No. of Same Bldg	Total Built Up Area (Sq.mt.)	Proposed FAR Area (Sq.mt.) Resi.	Total FAR Area (Sq.mt.)	Total Consumed Additional FAR Area (Sq.mt.)	Tnmt (No.)
A (BUILDING)	1	330.74	330.74	330.74	330.74	01
Grand Total :	1	330.74	330.74	330.74	330.74	01

Building USE/SUBUSE Details

Building Name	Building Use	Building SubUse	Building Structure
A (BUILDING)	Residential	Bungalow/ Dwelling / Non Apartment	Non-Highrise

SITE PLAN

LTP NAME AND SIGNATURE Mukesh Kumar CMC/ENG/0004/2017	STRUCTURAL ENG'S NAME AND SIGNATURE	BUILDER NAME AND SIGNATURE	DIGITAL SIGNATURE
---	-------------------------------------	----------------------------	-------------------